

SERVICE MANUAL

RA-1 CHASSIS

<u>MODEL</u>	<u>COMMANDER</u>	<u>DEST.</u>	<u>CHASSIS NO.</u>	<u>MODEL</u>	<u>COMMANDER</u>	<u>DEST.</u>	<u>CHASSIS NO.</u>
KP-41T25	RM-Y121	US	SCC-H53L-A	KP-46S17	RM-Y121	Canadian	SCC-H58J-A
KP-41T25	RM-Y121	Canadian	SCC-H58H-A	KP-53S17	RM-Y121	Canadian	SCC-H58K-A
KP-46S25	RM-Y118	US	SCC-H53J-A				
KP-53S25	RM-Y118	US	SCC-H53K-A				

Note :

1. This service manual handles differences from KP-41T15/46S15/53S15(RA-1 Chassis) service manual only. Please use this service manual together with that of KP-41T15/46S15/53S15(RA-1 Chassis).

KP-41T15/46S15/53S15(RA-1 Chassis) service manual
Part No.

	Service manual	Adjustment Manual
Part No.	9-965-042-01	9-965-043-01

2. Adjustment Manual for this model is separately published.

	Adjustment Manual
Part No.	9-965-101-11

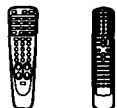

RM-Y121 RM-Y118

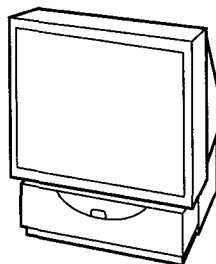

KP-41T25

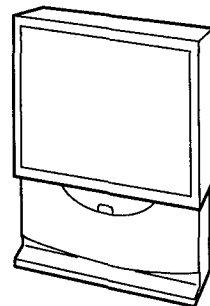

KP-46S25/53S25



※ Please file according to model size. ■



TRINITRON® COLOR TV
SONY®

SPECIFICATIONS

Projection system	3 picture tubes, 3 lenses, horizontal in-line system
Picture tube	7 inch high-brightness monochrome tubes (6.3 raster size), with optical coupling and liquid cooling system
Projection lenses	High performance, large-diameter hybrid lens F1.0
Screen size (measured diagonally)	KP-41T25 41 inches
	KP-46S17 46 inches
	KP-53S17 53 inches
	KP-46S25 46 inches
	KP-53S25 53 inches
Screen brightness	KP-41T25 1900 cd/m ²
	KP-46S17 1500 cd/m ²
	KP-53S17 1200 cd/m ²
	KP-46S25 1500 cd/m ²
	KP-53S25 1200 cd/m ²
Television system	American TV standards
Channel coverage	VHF : 2-13 / UHF : 14-69 / CATV : 1-125
Antenna	75 ohm external antenna terminal for VHF/UHF
Inputs/output	VIDEO IN 1
	S VIDEO IN (4-pin mini DIN) :
	Y : 1 V _{p-p} , 75-ohms
	unbalanced, sync negative
	C : 0.286 V _{p-p} (Burst signal) 75 ohms
	VIDEO (phone jack) :
	1 V _{p-p} , 75-ohms
	unbalanced, sync negative
	AUDIO (phone jacks) :
	500 mV _{rms} (100% modulation)
	Impedance : 47 kilohms
	VIDEO INPUT 2 and VIDEO IN 3
	VIDEO (phone jacks) :
1 V _{p-p} , 75-ohms	
unbalanced, sync negative	
AUDIO (phone jacks) :	
500 mV _{rms} (100% modulation)	
Impedance : 47 kilohms	
MONITOR OUT	
VIDEO (phone jack) :	
1 V _{p-p} , 75-ohms	
unbalanced, sync negative	
AUDIO (phone jacks) :	
500 mV _{rms} (100% modulation)	
Impedance : 10 kilohms	
AUDIO OUT (phono jacks) :	
900 mV _{rms} (100% modulation)	
Impedance : 5 kilohms	

Speaker	Full range speaker 100 mm (3.9 inches) diameter
Speaker output	10 W x 2
Power requirement	120 V, 60 Hz
Power consumption	220 W
	Standby mode : 4 W

	Dimensions (W/H/D)	Mass
KP-41T25	951 x 1,000 x 588 mm (37 1/2 x 39 3/8 x 23 1/4 inches)	53 kg (116 lbs 1 oz)
KP-46S17	1,066 x 1,306 x 543 mm (42 x 51 1/2 x 21 1/2 inches)	70 kg (154 lbs 5 oz)
KP-53S17	1,218 x 1,413 x 594 mm (48 x 55 3/4 x 23 1/2 inches)	75 kg (165 lbs 6 oz)
KP-46S25	1,066 x 1,306 x 543 mm (42 x 51 1/2 x 21 1/2 inches)	70 kg (154 lbs 5 oz)
KP-53S25	1,218 x 1,413 x 594 mm (48 x 55 3/4 x 23 1/2 inches)	75 kg (165 lbs 6oz)

Supplied accessories	Remote commander RM-Y121 (1)(For KP-41T25,46S17/53S17) RM-Y118 (1)(For KP-46S25,53S25) Size AA (R6) battery (1)
Optional accessories	U/V mixer EAC-66 Connecting cables RK-74A, VMC-810S/820S, YC-15V/30V, VMC-720M Video tray SU-PJT2 (For KP-46S17, KP-53S17,KP-46S25,KP-53S25) Stand SU-41T1 (For KP-41T25) High - contrast protective screen SCN-41X1 (For KP-41T25) SCN-46X1 (For KP-46S17,KP-46S25) SCN-53X1 (For KP-53S17,KP-53S25)

Design and specifications are subject to change without notice.

SAFETY CHECK-OUT (US model only)

After correcting the original service problem, perform the following safety checks before releasing the set to the customer:

1. Check the area of your repair for unsoldered or poorly-soldered connections. Check the entire board surface for solder splashes and bridges.
2. Check the interboard wiring to ensure that no wires are "pinched" or contact high-wattage resistors.
3. Check that all control knobs, shields, covers, ground straps, and mounting hardware have been replaced. Be absolutely certain that you have replaced all the insulators.
4. Look for unauthorized replacement parts, particularly transistors, that were installed during a previous repair. Point them out to the customer and recommend their replacement.
5. Look for parts which, through functioning, show obvious signs of deterioration. Point them out to the customer and recommend their replacement.
6. Check the line cords for cracks and abrasion. Recommend the replacement of any such line cord to the customer.
7. Check the condition of the monopole antenna (if any). Make sure the end is not broken off, and has the plastic cap on it. Point out the danger of impalement on a broken antenna to the customer, and recommend the antenna's replacement.
8. Check the B+ and HV to see they are at the values specified. Make sure your instruments are accurate; be suspicious of your HV meter if sets always have low HV.
9. Check the antenna terminals, metal trim, "metallized" knobs, screws, and all other exposed metal parts for AC leakage. Check leakage as described below.

LEAKAGE TEST

The AC leakage from any exposed metal part to earth ground and from all exposed metal parts to any exposed metal part having a return to chassis, must not exceed 0.5mA (500 microamperes). Leakage current can be measured by any one of three methods.

1. A commercial leakage tester, such as the Simpson 229 or RCA WT-540A. Follow the manufacturers' instructions to use these instruments.
2. A battery-operated AC milliammeter. The Data Precision 245 digital multimeter is suitable for this job.
3. Measuring the voltage drop across a resistor by means of a VOM or battery-operated AC voltmeter. The "limit" indication is 0.75V, so analog meters must have an accurate low-voltage scale. The Simpson 250 and Sanwa SH-63Trd are examples of a passive VOM that is suitable. Nearly all battery-operated digital multimeters that have a 2V AC range are suitable (See Fig. A)

HOW TO FIND A GOOD EARTH GROUND

A cold-water pipe is guaranteed earth ground; the cover-plate retaining screw on most AC outlet boxes is also at earth ground. If the retaining screw is to be used as your earth-ground, verify that it is at ground by measuring the resistance between it and a cold-water pipe with an ohmmeter. The reading should be zero ohms. If a cold-water pipe is not accessible, connect a 60-100 watts trouble light (not a neon lamp) between the hot side of the receptacle and the retaining screw. Try both slots, if necessary, to locate the hot side of the line, the lamp should light at normal brilliance if the screw is at ground potential. (See Fig. B)

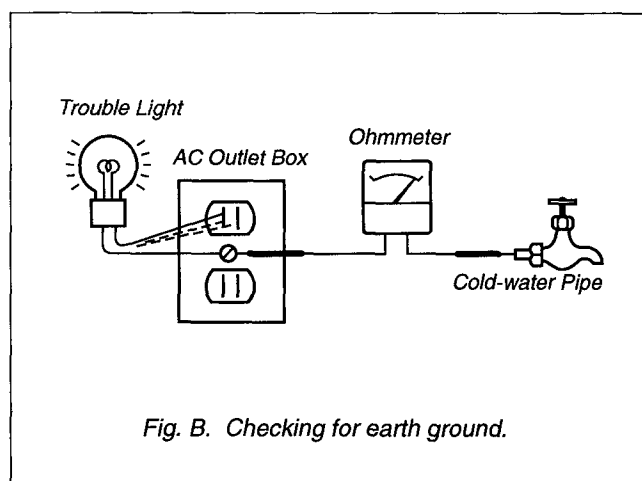
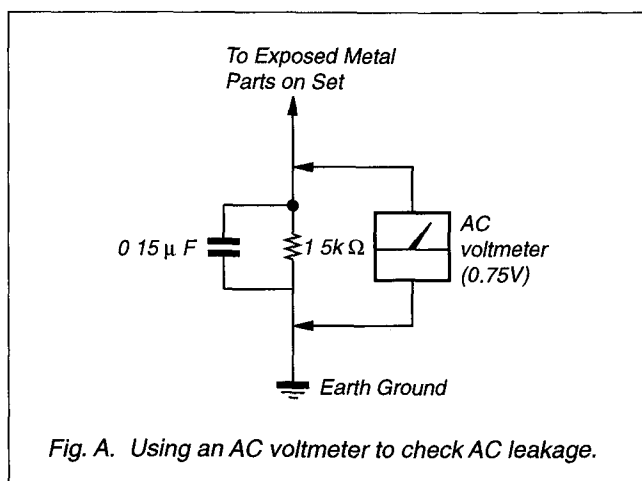

TABLE OF CONTENTS

<u>Section</u>	<u>Title</u>	<u>Page</u>	<u>Section</u>	<u>Title</u>	<u>Page</u>
1. GENERAL			2-9-1.	BEZNET REMOVAL (KP-41T25).....	27
	Step 1 : Installing the projection TV	5	2-9-2.	BEZNET REMOVAL (KP-46S25/53S25)	27
	Step 2 : Connections	6	2-10-1	MIRROR COVER REMOVAL (KP-41T25).....	28
	Step 3 : Setting up the remote commander ..	11	2-10-2	MIRROR COVER REMOVAL (KP-46S25/53S25)	28
	Step 4 : Setting up the projection TV automatically (AUTO SET UP)	12	2-11.	HIGH-VOLTAGE CABLE INSTALLATION AND REMOVAL	28
	Watching TV programs	14	2-12.	PICTURE TUBE REMOVAL	28
	Watching tow programs at one time-PIP	15			
	Selecting picture and sound effects (PROGRAM PALETTE)	16	3. SAFETY RELATED ADJUSTMENTS		29
	Adjusting the picture(VIDEO)	16			
	Adjusting the color temperature(TRINITONE)	17	4. DIAGRAMS		
	Reducing picture noise(NR)	17	4-1.	Circuit Boards Location	35
	Adjusting sound(AUDIO)	17	4-2	Printed Wiring Board and Schematic Diagrams	35
	Listening to surround sound(SURROUND) ..	18		• HA Board	36
	Selecting stereo or bilingual programs(MTS) ..	18		• A Board	41
	Setting the speaker switch(SPEAKER)	18		• D Board	44
	Setting audio out (AUDIO OUT)	18		• U Board	51
	Setting daylight saving time (DAYLIGHT SAVING)	19		• M Board	54
	Setting the clock (CURRENT TIME SET)	19		• P Board	61
	Setting the timer to turn the projection TV on and off (ON/OFF TIMER)	20		• E Board	66
	Blocking out a channel(CHANNEL BLOCK)	20		• G Board	73
	Customizing the channel number buttons (CH CAPTION/GUIDE)	21		• ZB Board	78
	Setting video labels(VIDEO LABEL)	21		• ZG Board	76
	Displaying Caption Vision(CAPTION VISION/XDS)	22		• ZR Board	77
	Operating video equipment	22		• CR Board	81
	Operating a cable box	23		• CG Board	82
	Troubleshooting	24		• CB Board	83
			4-3	Semiconductions	85
2. DISASSEMBLY			5. EXPLODED VIEWS		
	2-1-1 REAR PLATE REMOVAL (KP-41T25)	25	5-1.	SCREEN AND CONTROL BLOCK	87
	2-1-2. REAR PLATE REMOVAL (KP-46S25/53S25)	25	5-2	MIRROR COVER AND POWER BLOCK	88
	2-2. CHASSIS ASSY REMOVAL	25	5-3.	DC AND E BLOCK	89
	2-3. SERVICE POSITION	25	5-4.	SHIELD AND MIRROR HOLDER BLOCK	90
	2-4 G BOARD REMOVAL	26	6. ELECTRICAL PARTS LIST		91
	2-5. D BOARD REMOVAL	26			
	2-6. U BOARD REMOVAL	26			
	2-7. M BOARD REMOVAL	26			
	2-8-1. HA BOARD REMOVAL (KP-41T25)	27			
	2-8-2. HA BOARD REMOVAL (KP-46S25/53S25)	27			

(CAUTION)

SHORT CIRCUIT THE ANODE OF THE PICTURE TUBE AND THE ANODE CAP TO THE METAL CHASSIS, CRT SHIELD, OR CARBON PAINTED ON THE CRT, AFTER REMOVING THE ANODE.

WARNING!!

AN ISOLATION TRANSFORMER SHOULD BE USED DURING ANY SERVICE TO AVOID POSSIBLE SHOCK HAZARD, BECAUSE OF LIVE CHASSIS.
THE CHASSIS OF THIS RECEIVER IS DIRECTLY CONNECTED TO THE AC POWER LINE.

SAFETY-RELATED COMPONENT WARNING!!

COMPONENTS IDENTIFIED BY SHADING AND MARK Δ ON THE SCHEMATIC DIAGRAMS, EXPLODED VIEWS AND IN THE PARTS LIST ARE CRITICAL TO SAFE OPERATION. REPLACE THESE COMPONENTS WITH SONY PARTS WHOSE PART NUMBERS APPEAR AS SHOWN IN THIS MANUAL OR IN SUPPLEMENTS PUBLISHED BY SONY. CIRCUIT ADJUSTMENTS THAT ARE CRITICAL TO SAFE OPERATION ARE IDENTIFIED IN THIS MANUAL. FOLLOW THESE PROCEDURES WHENEVER CRITICAL COMPONENTS ARE REPLACED OR IMPROPER OPERATION IS SUSPECTED.

(ATTENTION)

APRES AVOIR DECONNECTE LE CAP DE L'ANODE, COURT-CIRCUITER L'ANODE DU TUBE CATHODIQUE ET CELUI DE L'ANODE DU CAP AU CHASSIS METALLIQUE DE L'APPAREIL, OU AU COUCHE DE CARBONE PEINTE SUR LE TUBE CATHODIQUE OU AU BLINDAGE DU TUBE CATHODIQUE.

ATTENTION!!

AFIN D'EVITER TOUT RISQUE DELECTROCUTION PROVENANT D'UN CHASSIS SOUS TENSION, UN TRANSFORMATEUR D'ISOLEMENT DOIT ETRE UTILISÉ LORS DE TOUT DEPANNAGE. LE CHASSIS DE CE RECEPTEUR EST DIRECTEMENT RACCORDÉ À L'ALIMENTATION SECTEUR.

ATTENTION AUX COMPOSANTS RELATIFS À LA SÉCURITÉ!!

LES COMPOSANTS IDENTIFIÉS PAR UNE TRAME ET PAR UNE MAPQUE Δ SUR LES SCHÉMAS DE PRINCIPE, LES VUES EXPLODÉES ET LES LISTES DE PIÈCES CONT D'UNE IMPORTANCE CRITIQUE POUR LA SÉCURITÉ DU FONCTIONNEMENT. NE LES REMPLACER QUE PAR DES COMPOSANTS SONY DONT LE NUMÉRO DE PIÈCE EST INDIQUÉ DANS LE PRÉSENT MANUEL OU DANS DES SUPPLÉMENTS PUBLIÉS PAR SONY. LES RÉGLAGES DE CIRCUIT DONT L'IMPORTANCE EST CRITIQUE POUR LA SÉCURITÉ DU FONCTIONNEMENT SONT IDENTIFIÉS DANS LE PRÉSENT MANUEL. SUIVRE CES PROCÉDURES LORS DE CHAQUE REMPLACEMENT DE COMPOSANTS CRITIQUES, OU LORSQU'UN MAUVAIS FONCTIONNEMENT EST SUSPECTÉ.

SECTION 2 DISASSEMBLY

The operation instruction mentioned here are partial abstracts from the Operating Instruction Manual. The page numbers of the Operating Instruction Manual remain as in the manual.(part no: 3-856-233-11)

Getting Started

Welcome!

Thank you for purchasing the Sony Color Rear Video Projection TV. Here are some of the features you will enjoy with your projection TV:

- AUTO SET UP feature that allows you to set up your projection TV easily by pressing the SET UP button
- On screen menus that let you set the picture quality, sound, and other settings
- Picture-in-Picture that allows you to watch another TV channel, video or cable image as a window picture
- On/off timer that allows you to make the TV program of your choice be displayed on the screen for a specified duration
- Dynamic Focus circuitry that automatically focuses the scanning electron beam for enhanced sharpness, especially at the corners
- Universal remote commander supplied that allows you to operate Sony and other manufacturers' video equipment

About this manual

The instructions in this manual are for models KP-41T25, KP-46S17 and KP-53S17. Before you start reading this manual, please check your model number, located at the rear of the projection TV. Model KP-46S17 is used for illustration purposes in this manual. Model KP-41T25 incorporates two tuners that enable you to operate PIP feature without connecting a VCR. Models KP-46S17 and KP-53S17 incorporate one tuner. These models must be connected to a VCR to enjoy PIP. The differences in specifications are indicated in the text.

Instructions in this manual are based on use of the remote commander. You can also use the controls on the projection TV if they have the same name as those on the remote commander.

Precautions

This projection TV operates on extremely high voltage. To prevent fire or electric shock, please follow the precautions below.

Safety

- Operate the projection TV only on 120 V AC.
- One blade of the plug is wider than the other for safety purposes and will fit into the power outlet only one way. If you are unable to insert the plug fully into the outlet, contact your dealer.
- Should any liquid or solid object fall into the cabinet, unplug the projection TV and have it checked by qualified personnel before operating it further.
- Unplug the projection TV from the wall outlet if you are not going to use it for several days or more. To disconnect the cord, pull it out by the plug. Never pull the cord itself.

For details concerning safety precautions, see the supplied leaflet "IMPORTANT SAFEGUARDS."

Note on cleaning

Clean the cabinet of the projection TV with a dry soft cloth. To remove dust from the screen, wipe it gently with a soft cloth using vertical strokes only. Stubborn stains may be removed with a cloth slightly dampened with solution of mild soap and warm water. Never use strong solvents such as thinner or benzine for cleaning. If the picture becomes dark after using the projection TV for a long period of time, it may be necessary to clean the inside of the projection TV. Consult qualified service personnel.

Installing

- To prevent internal heat build-up, do not block the ventilation openings.
- Do not install the projection TV in a hot or humid place, or in a place subject to excessive dust or mechanical vibration.
- Avoid operating the projection TV at temperatures below 5°C (41°F).
- If the projection TV is transported directly from a cold to a warm location, or if the room temperature has changed suddenly, the picture may be blurred or show poor color. This is because moisture has condensed on the mirror or lenses inside. If this happens, let the moisture evaporate before using the projection TV.
- To obtain the best picture, do not expose the screen to direct illumination or direct sunlight. It is recommended to use spot lighting directed down from the ceiling or to cover the windows that face the screen with opaque drapery. It is desirable to install the projection TV in a room where the floor and walls are not of reflecting material. If necessary, cover them with dark carpeting or wall paper.

Step 1: Installing the projection TV

For the best picture quality, install the projection TV within the areas shown below.

Optimum viewing area (Horizontal)

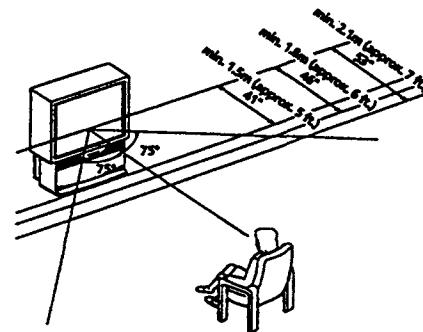

Optimum viewing area (Vertical)

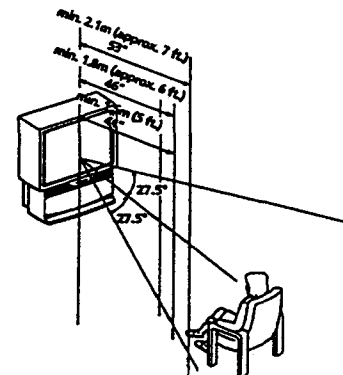

Carrying your projection TV

Be sure to grasp the portions indicated when carrying the projection TV, and to use more than two people.

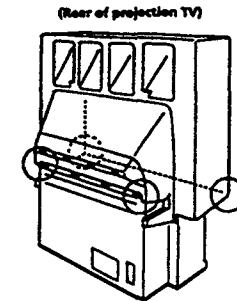

Preparing for your projection TV

Before you use your projection TV, adjust convergence. For the procedure, see "Step 4: Setting up the projection TV automatically (AUTO SET UP)" on page 18.

Step 2: Connections

Although you can use either an indoor antenna or outdoor antenna with your projection TV, we recommend connecting to an outdoor antenna or a cable TV system for improved picture quality.

To an antenna

Connect your antenna cable to the VHF/UHF antenna terminal. If you cannot connect your antenna cable directly to the terminal, follow one of the instructions below depending on your cable type.

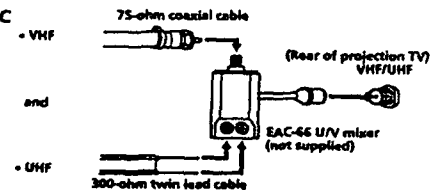
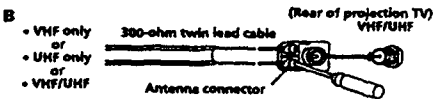

Notes

- Most VHF/UHF combination antennas have a signal splitter. Remove the splitter before attaching the appropriate connector.
- If you use the U/V mixer, snow and noise may appear in the picture when viewing cable TV channels over 37(W+1).

Connecting an antenna/cable TV system without a VCR

To cable or antenna

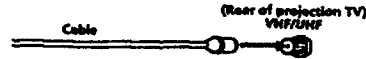

To cable box

If your cable company requires you to connect a cable box, make the connection as follows:

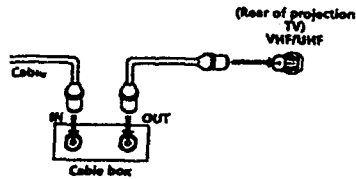

To cable box and cable (KP-41T25 only)

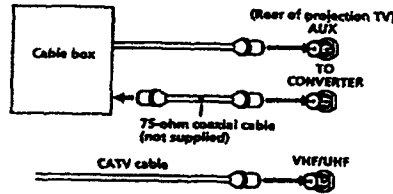

Pay cable TV systems use scrambled or encoded signals requiring the cable box* in addition to the normal cable connection.

* The cable box will be supplied by the cable company.

Note

- You cannot watch the signal through AUX connector as a window picture.

To cable and antenna (KP-41T25 only)

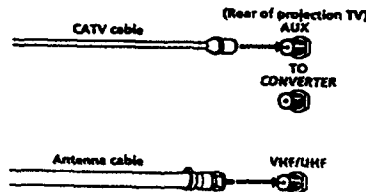

Note

- Do not connect anything to the TO CONVERTER connector in this case.

Connecting an antenna/cable TV system with a VCR

For details on connection, see the instruction manual of your VCR. For KP-46S17/53S17, a VCR must be connected to your TV to watch two TV channels at one time (PIP feature).

Before connecting, disconnect the AC power cords of the equipment to be connected.

After making these connections, you will be able to do the following:

- View the playback of video tapes
- Record one TV program while viewing another program
- Watch two TV programs at one time using a window picture (Picture-in-Picture)

To a conventional VCR

Without a cable box

■ KP-41T25

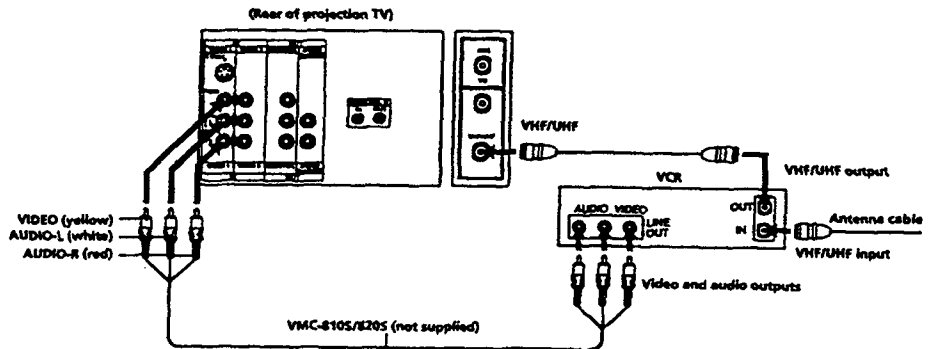

■ KP-46S17/53S17

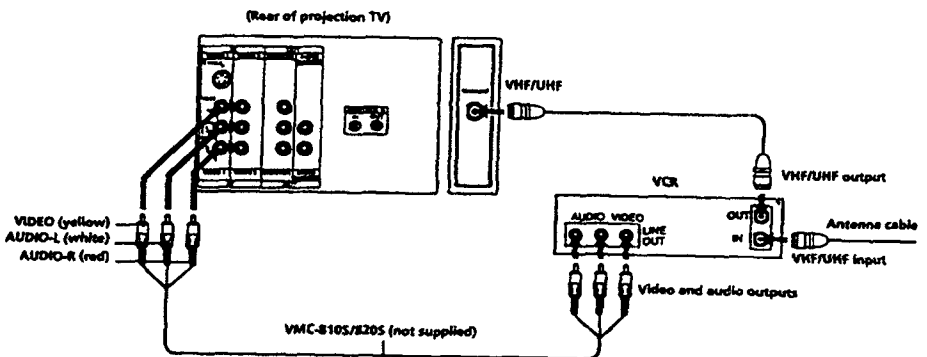

Notes

- To connect a monaural VCR, connect the audio output of the VCR to AUDIO-L (MONO) of VIDEO 1/3 IN on the projection TV.

- Do not connect the cable to the S VIDEO connector on the projection TV.

With a cable box

■ KP-41725

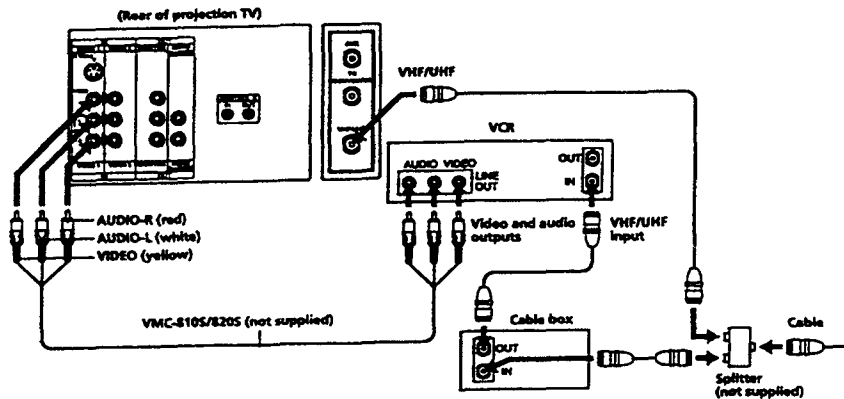

■ KP-46S17I53S17

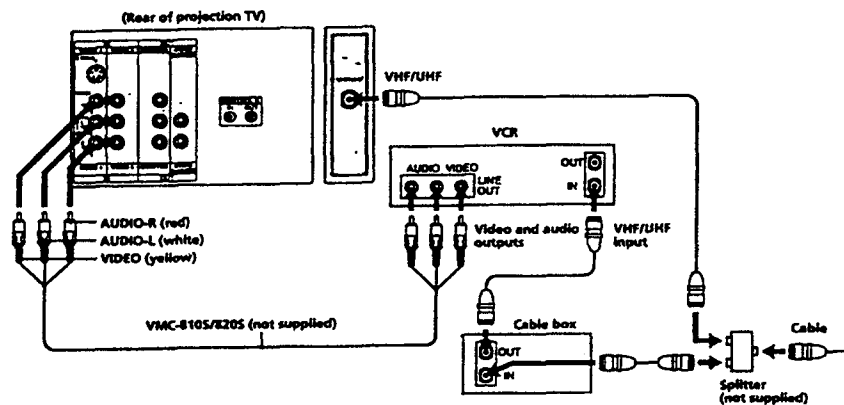

To an S video equipped VCR

If your VCR has an S video output jack, make the connection as follows.

Whenever you connect the cable to the S VIDEO connector, the projection TV automatically receives S video signals.

Without a cable box

■ KP-41725

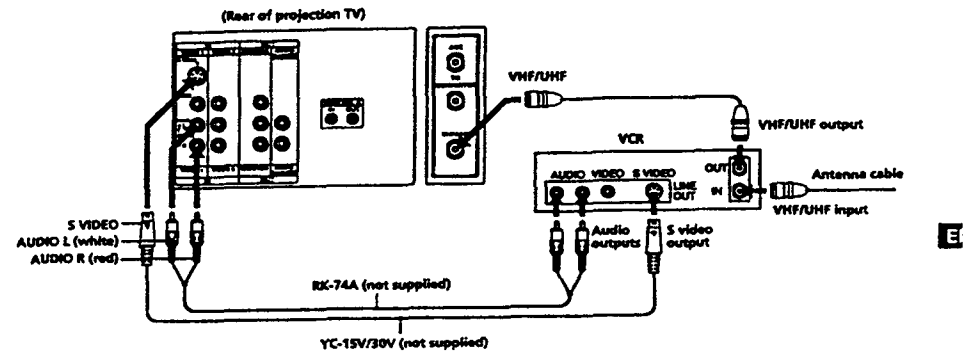

■ KP-46S17I53S17

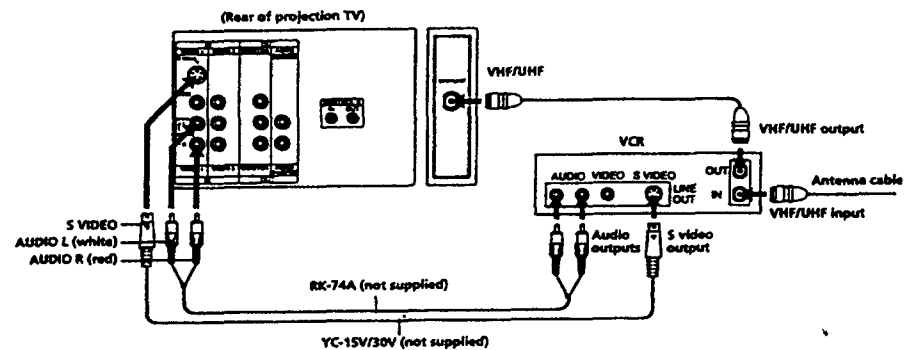

Note

- Video signals are composed of Y (luminance) and C (chroma) signals. The S connection sends the two signals separately preventing degradation, and gives better picture quality compared to conventional connection.

With a cable box

■ KP-41725

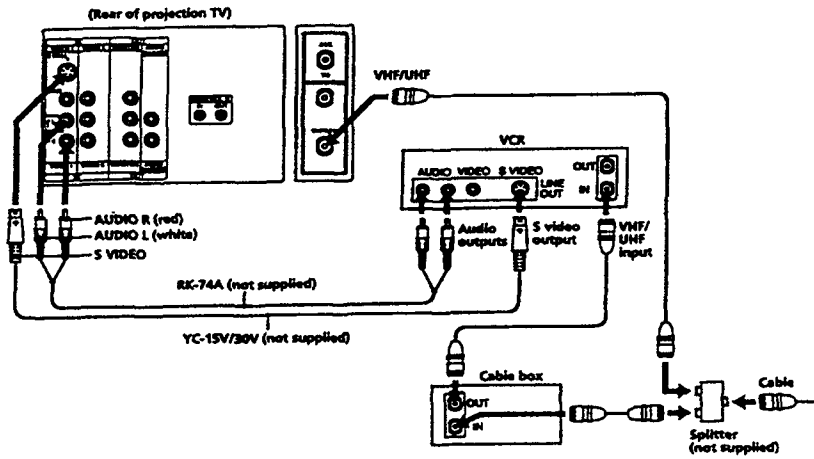

■ KP-46S17/53S17

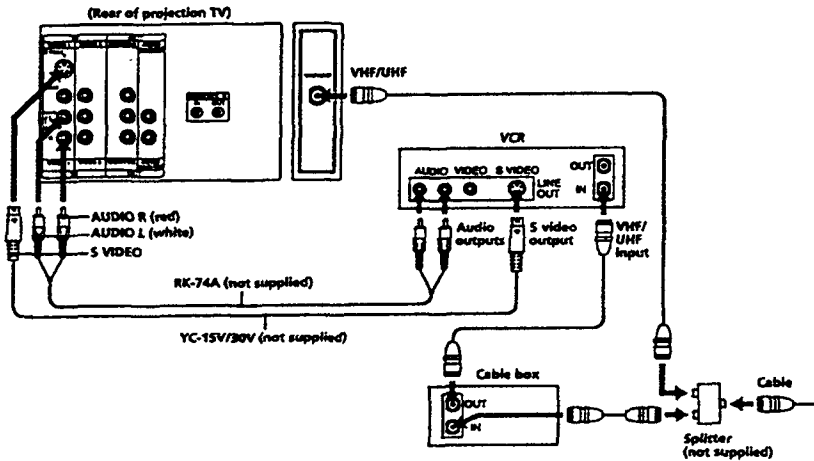

Connecting a DBS receiver

For connection details, see the instruction manual of the DBS (Digital Broadcasting Satellites) receiver.

To a TV

■ KP-41725

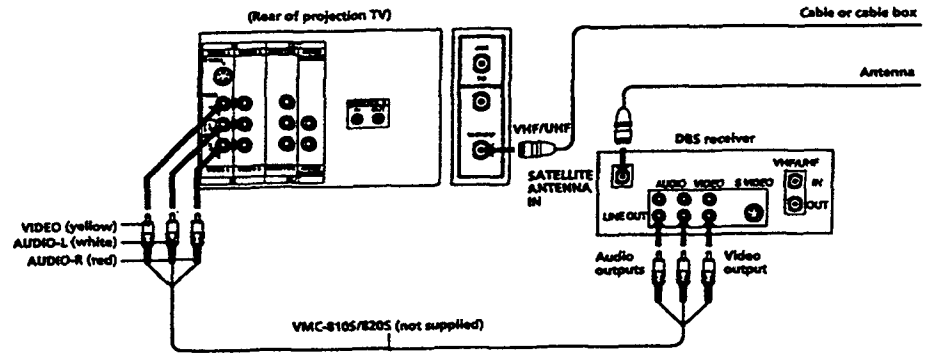

■ KP-46S17/53S17

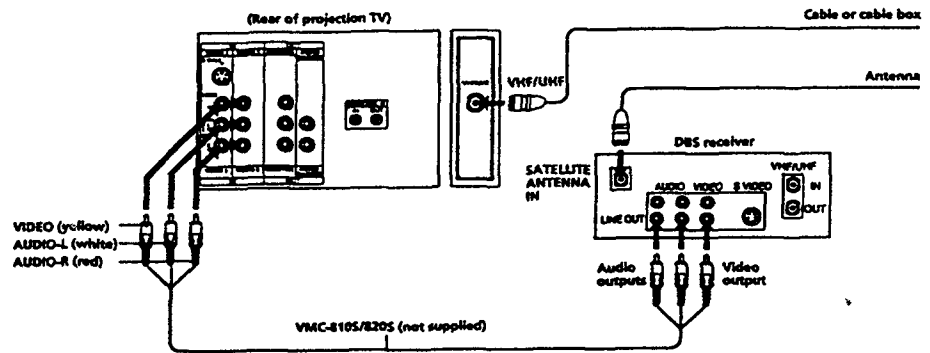

Note

- You can use the S VIDEO jack or the composite video jack for video connection.

To a TV and VCR

■ KP-41725

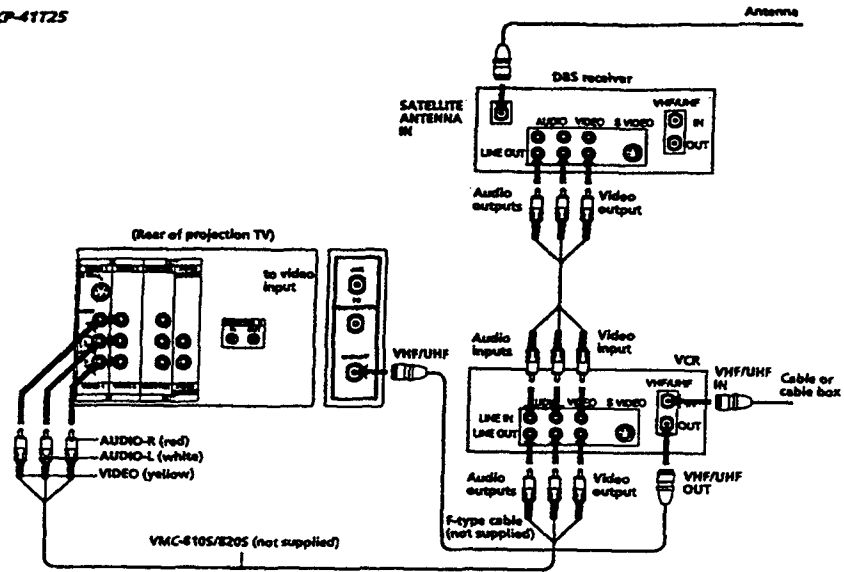

■ KP-46S17153517

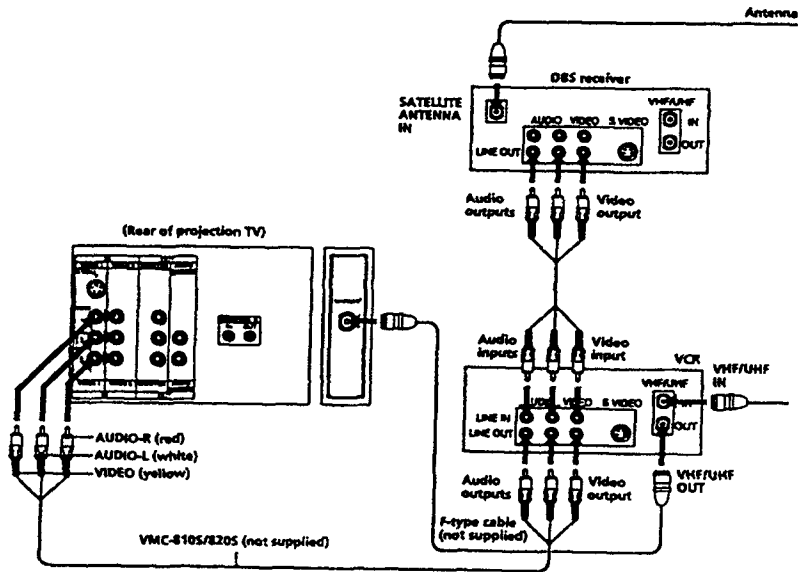

12-EN | Getting Started

Connecting a camcorder

This connection is convenient for watching the picture from a camcorder.

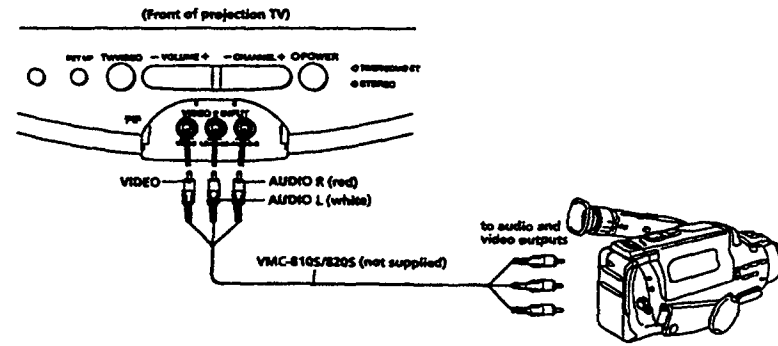

Note

- To connect a monaural camcorder, connect the audio output of the camcorder to AUDIO L (MONO) of VIDEO 2 INPUT on the projection TV.

Getting Started | 13-EN

Connecting two VCRs for tape editing

You can record input images displayed on the screen. This type of connection should be used only when you connect from the line input of one VCR, and from the line output of a second VCR.

■ KP-41725

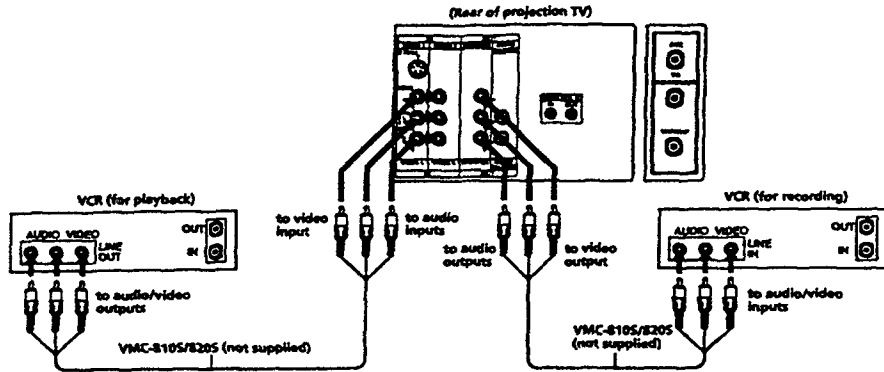

■ KP-46S17/53S17

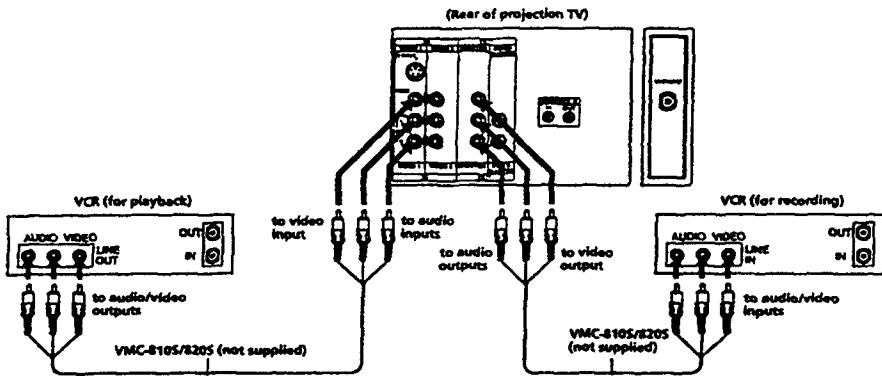

Notes

- Do not change the input signal while editing, or the output signal will also change.
- When connecting a single VCR to the projection TV, do not connect MONITOR OUT to the VCR's line input, while at the same time connecting from the projection TV's VIDEO IN jacks to the VCR's line output.
- You can use the S video connector to connect a VCR for playback and the composite video jack to connect a VCR for recording.

Connecting an audio system

When connecting audio equipment, see page 31 for more information.

■ KP-41725

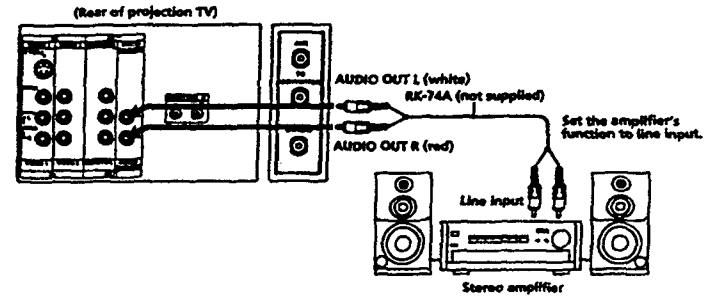

■ KP-46S17/53S17

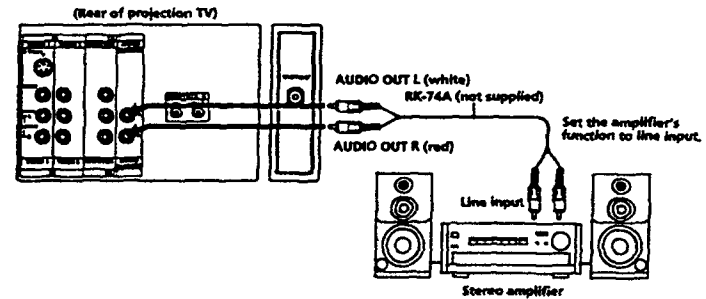

Note

- You can adjust the bass, treble and balance, or select surround or an MTS (Multichannel TV Sound) mode with the supplied remote commander.

Connecting other Sony equipment with CONTROL S jack

This feature allows you to control your projection TV and other Sony equipment with one remote commander.

- To control other Sony equipment with the projection TV's remote commander, connect the input of the equipment to CONTROL S OUT jack on the projection TV.
- To control the projection TV with the remote commander of other Sony equipment, connect the output of the equipment to CONTROL S IN jack on the projection TV.

■ KP-41725

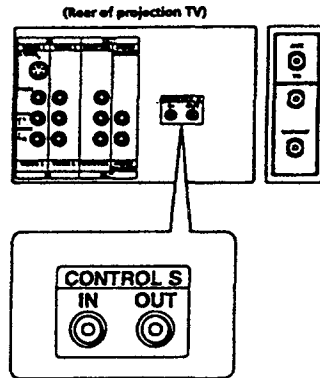

■ KP-46S17/IS3517

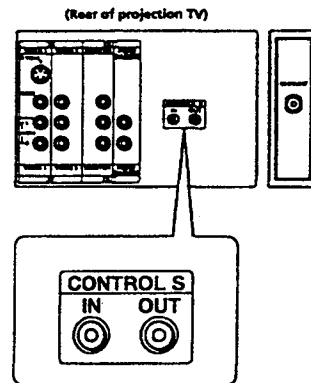

Step 3: Setting up the remote commander

Insert one size AA (R6) battery (supplied) by matching the + and - on the battery to the diagram inside the battery compartment.

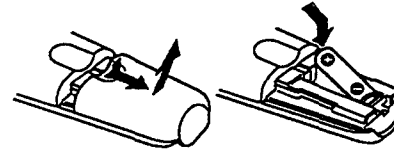

Notes

- With normal use, the battery should last for approximately six months.
- If you do not use the remote commander for an extended period of time, remove the battery to avoid possible damage from battery leakage.
- Do not handle the remote commander roughly. Do not drop it, step on it or let it get wet.
- Do not place the remote commander in direct sunlight, near a heater, or where the humidity is high.

Using the remote commander

The upper half of the remote commander has three selectable operation modes. Each button in this area has three different functions. You can select the mode by sliding a selector on the left side.

For normal TV viewing

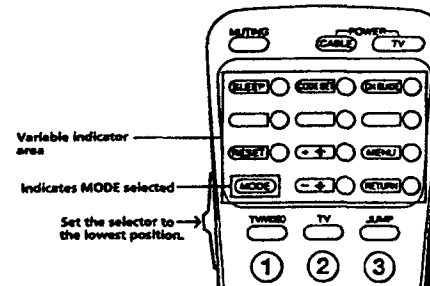

For operating video equipment

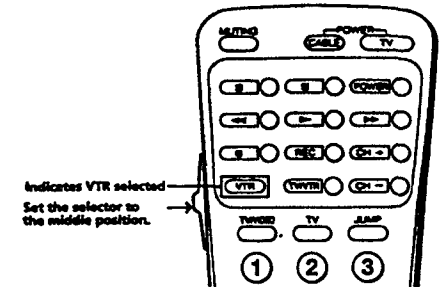

For using the Picture-in-Picture feature

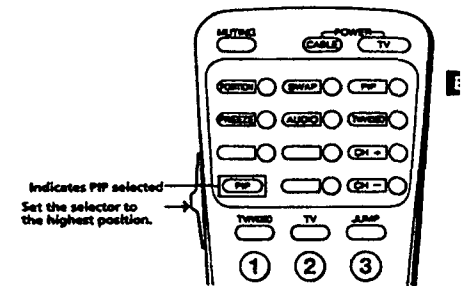

Step 4: Setting up the projection TV automatically (AUTO SET UP)

You can set up your projection TV easily by using AUTO SET UP feature. It presets all the receivable channels, adjusts the convergence and changes the on-screen menu language. To set up the projection TV manually, see "Presetting channels" (page 22), "Setting cable TV on or off" (page 21), "Adjusting convergence" (page 20) and "Changing the menu language" (page 22).

If the projection TV is set to a video input, you cannot execute AUTO SET UP. Press TV/VIDEO so that a channel number appears.

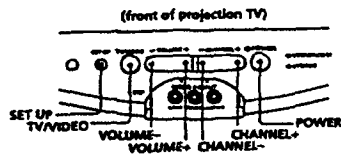

1 Press POWER to turn the projection TV on.



2 Press SET UP on the front of the projection TV.

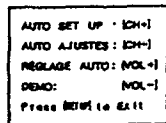

3 Press CHANNEL+ to start AUTO SET UP. If you prefer Spanish or French to English, you can change the on-screen menu language. Press CHANNEL- for Spanish or VOLUME+ for French.

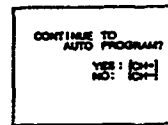
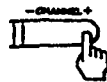

All of the menus will be set to the factory preset condition in the selected language.

4 Press CHANNEL+ to preset channels.

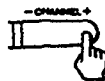

"AUTO PROGRAM" appears on the screen and the TV starts scanning and presetting channels automatically. When all the receivable channels are stored, "AUTO PROGRAM" disappears and the following menu appears. If the projection TV receives cable TV channels, CATV is set to ON automatically.

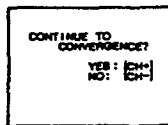

5 Adjust convergence.

(1) Press CHANNEL+. The CONVERGENCE adjustment screen appears.

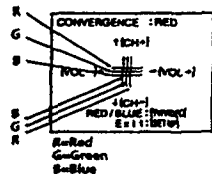
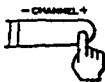

(2) Press TV/VIDEO to select RED or BLUE.

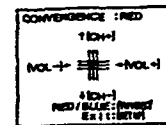

(3) Using CHANNEL+/- or VOLUME+/-, move the line until it converges with the center green line.

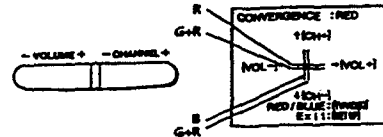

To move horizontal line up/down, press CHANNEL+/-.
To move vertical line right/left, press VOLUME+/-.

(4) Repeat steps (2) and (3) to adjust the other lines until all three lines converge and are seen as a white cross.

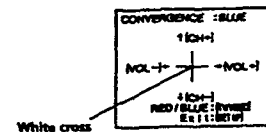

Notes

- If more than 90 seconds elapse after you press a button, the menu disappears automatically.
- In case of using the AUX connector, press the TV button on the remote commander first and make sure that "AUX" is displayed beside the channel number on the screen. Then follow steps 2 to 5 above to perform AUTO SET UP (KP-41T25 only).

To preview the main functions (DEMO)

Press VOLUME- in step 3. The functions and menus are displayed one by one.

Erasing or adding channels

After AUTO SET UP you can erase unnecessary channels or add the channels you want. Preset channels during the day rather than late at night, when some channels may not be broadcasting.

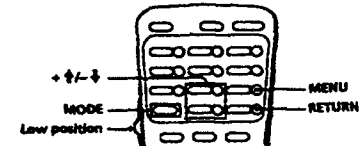

1 Press MENU. The main menu appears.



2 Press + or - to move the cursor (▸) to SET UP and press RETURN. The SET UP menu appears.

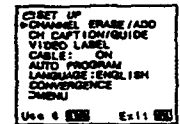

3 Make sure the cursor (▸) is beside CHANNEL ERASE/ADD and press RETURN. If the cursor is not beside CHANNEL ERASE/ADD, press + or - to move the cursor and press RETURN. The CHANNEL ERASE/ADD menu appears.

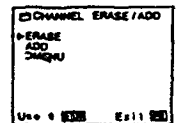

(continued)

4 Erase and/or add the channel you want:

To erase an unwanted channel:

- Make sure the cursor (P) is beside ERASE.
- Press CH + or - to select the channel you want to erase.

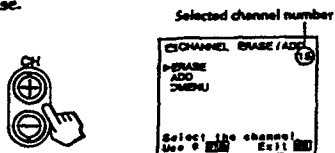

(3) Press RETURN.

The indication "-" appears beside the channel number, showing that the channel is erased from the preset memory.



To add a channel that you want

- Press + ↑ or - ↓ to select ADD.
- Press 0 - 9 button to select the channel you want to add and press ENTER.

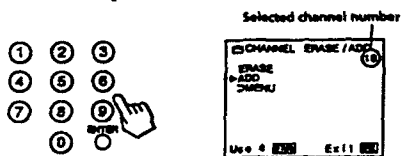

(3) Press RETURN.

The indication "+" appears beside the channel number, showing that the channel is added to the preset memory.



5 To erase and/or add other channels, repeat step 4.

6 When you finish, press MENU.



Notes

- If you erase or add a VHF or UHF channel, the cable TV channel with the same number is also erased or added, and vice versa.
- If more than 90 seconds elapse after you press a button, the menu disappears automatically.
- Erasing and adding channels are also available for the AUX input (KP-41725 only).

Adjusting convergence (CONVERGENCE)

The projection tube image appears on the screen in three layers (red, green and blue). If they do not converge, the color is poor and the picture blurs. To correct this, adjust convergence.

You do not have to do this procedure if you execute AUTO SET UP (page 18). Do this procedure only when you want to adjust it manually.

1 Press MENU.

2 Press + ↑ or - ↓ to move the cursor (P) to SET UP and press RETURN.

3 Press + ↑ or - ↓ to move the cursor (P) to CONVERGENCE and press RETURN.

The CONVERGENCE adjustment screen appears.

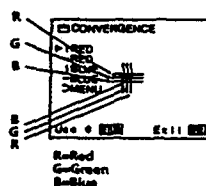

4 Press + ↑ or - ↓ to move the cursor (P) to the symbol showing the line you want to adjust, and press RETURN.

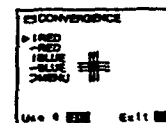

- RED: Red vertical line (left/right adjustment)
- RED: Red horizontal line (up/down adjustment)
- BLUE: Blue vertical line (left/right adjustment)
- BLUE: Blue horizontal line (up/down adjustment)

5 Press + ↑ or - ↓ to move the line until it converges with the center green line, and press RETURN.

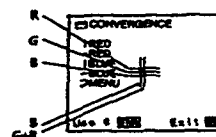

To move up/right, press + ↑.
To move down/left, press - ↓.

6 Repeat steps 4 and 5 to adjust other lines until all three lines converge and are seen as a white cross.

7 Press MENU to return to the original screen.

Setting cable TV on or off

If you have connected the projection TV to a cable TV system, set CABLE to ON, the factory setting. If not, set CABLE to OFF.

You do not have to do this procedure if you execute AUTO SET UP (page 18). Do this procedure only when you want to set it manually.

1 Press MENU.

2 Press + ↑ or - ↓ to move the cursor (P) to SET UP and press RETURN.

3 Press + ↑ or - ↓ to move the cursor (P) to CABLE and press RETURN.

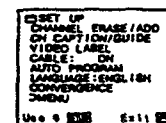

4 Press + ↑ or - ↓ to select ON or OFF and press RETURN.

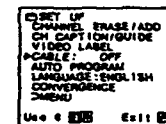

5 Press MENU to return to the original screen.

Note

- If CABLE appears in black, the projection TV is set to a video input and you cannot select CABLE. Press TV on the remote commander so that a channel number appears.

(continued)

Presetting channels

You can preset TV channels easily by AUTO PROGRAM feature. You do not have to do this procedure if you execute AUTO SET UP (page 18). Do this procedure only when you want to set it manually.

- 1 Press MENU.
- 2 Press +↑ or -↓ to move the cursor (▶) to SET UP and press RETURN.

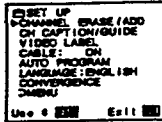

- 3 Press +↑ or -↓ to move the cursor (▶) to AUTO PROGRAM and press RETURN.



"AUTO PROGRAM" appears on the screen and the projection TV starts scanning and presetting channels automatically. When all the receivable channels are stored, "AUTO PROGRAM" disappears and the lowest numbered channel is displayed.

- 4 Press MENU to return to the original screen.

Notes

- If AUTO PROGRAM appears in black in the SET UP menu, the projection TV is set to a video input and you cannot select AUTO PROGRAM. Press TV/VIDEO or TV on the remote commander so that a channel number appears.
- If more than 90 seconds elapse after you press a button, the menu disappears automatically.
- Presetting channels is also available for the AUX input. (KP-41T25 only)

Changing the menu language

If you prefer Spanish or French to English, you can change the menu language. You do not have to do this procedure if you execute AUTO SET UP (page 18). Do this procedure only when you want to set it manually.

- 1 Press MENU.
- 2 Press +↑ or -↓ to move the cursor (▶) to SET UP and press RETURN.
- 3 Press +↑ or -↓ to move the cursor (▶) to LANGUAGE and press RETURN.

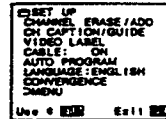

- 4 Press +↑ or -↓ to select the language and press RETURN. The menu in selected language appears.



- 5 Press MENU to return to the original screen.

Note

- Even when you select Spanish or French language, certain parts of the menus remain in English.

Operations

Watching TV programs

Check that the CABLE BOX/TV selector is set to TV.

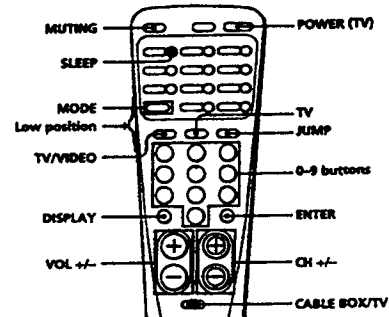

- 1 Press POWER (TV) to turn on the projection TV. The TIMER/STAND BY indicator flashes until the picture appears.



If "VIDEO" appears on the screen, press the TV/VIDEO or TV button so that a channel number appears.

- 2 Select the channel you want to watch: To select a channel directly Press the 0-9 buttons and then press ENTER. For example, to select channel 10, press 1, 0 and ENTER.

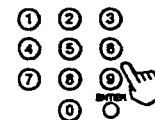

To scan through channels

Press CH +/- until the channel you want to watch appears.



- 3 Press VOL +/- to adjust the volume.



Switching quickly between two channels

Press JUMP. The channel you previously selected with the 0-9 buttons appears.



Pressing JUMP again switches back the channel.

Muting the sound

Press MUTING. "MUTING" appears on the screen.



To restore the sound, press MUTING again, or press VOL +.

Displaying on-screen information

Press DISPLAY repeatedly until the desired display appears.

Each time you press DISPLAY, the display changes as follows:

Status display* → XDS** → Caption Vision***
 ↳ DISPLAY OFF ↳



- * Channel number, the current time, channel caption (if set), and MTS mode (if SAP is selected) are displayed. SAP indication disappears after three seconds.

- ** Some programs are broadcast with XDS (Extended Data Service) which shows a network name, program name, program type, program length, call letters, and time of the show. When you select XDS with the DISPLAY button, this information will be displayed on the screen if the broadcaster offers this service.

(continued)

Some programs are broadcast with Caption Vision. When you select Caption Vision with the DISPLAY button, Caption Vision will be displayed on the screen if the broadcaster offers this service. (See page 38 for selecting Caption Vision.)

To cancel the display, press DISPLAY repeatedly until "DISPLAY OFF" appears. "DISPLAY OFF" goes off after three seconds.

Setting the Sleep Timer

The projection TV stays on for the length of time you specify and then shuts off automatically.

Press SLEEP repeatedly until the time (in minutes) you want appears. Each time you press SLEEP, the time changes as follows: 30 → 60 → 90 → OFF.



"SLEEP" appears about one minute before the projection TV shuts off.

To cancel the Sleep Timer, press SLEEP repeatedly until "SLEEP OFF" appears, or turn off the projection TV.

The sleep timer is also cancelled when you select AUTO PROGRAM under the SET UP menu.

Watching a video input picture

Press TV/VIDEO repeatedly until the desired video input appears. Each time you press TV/VIDEO, the display changes as follows: TV → VIDEO 1 → VIDEO 2 → VIDEO 3.



To return to TV picture, press TV.

Changing the VHF/UHF input to the AUX input (KP-41T25 only)

Press TV. "AUX" appears beside the channel number.



Pressing TV again switches back to the previous input.

Watching two programs at one time — PIP

The Picture-in-Picture (PIP) feature allows you to watch both the main picture and a window picture simultaneously.

For KP-46S17/53S17, your projection TV must be connected to a VCR to watch two TV channels at one time. See "Connecting an antenna/cable TV system with a VCR" (pages 7 to 10) for connections.

For KP-41T25, the Picture-in-Picture (PIP) feature allows you to watch two TV channels at one time.

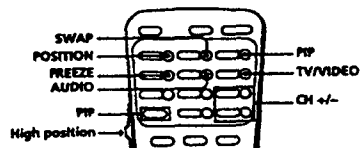

Displaying a window picture

Press PIP.

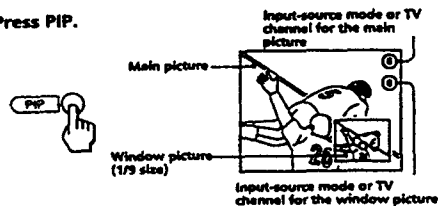

Press PIP again to display a smaller window picture.

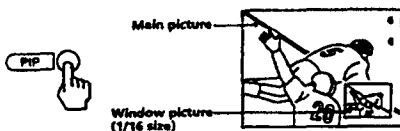

Each time you press PIP, the size of the window picture changes as follows: 1/9 size → 1/16 size → OFF.

To remove the window picture, press PIP repeatedly until the window picture disappears.

Notes

- If the main picture is not receiving an image, the window picture may be in black and white.
- The window picture sound is also output from the AUDIO (VAR/FDO OUT) jacks when you listen to it.

Changing the window picture input mode

Press TV/VIDEO in the PIP control area of the remote commander to select the input mode. Each time you press TV/VIDEO, "TV," "VIDEO 1," "VIDEO 2" and "VIDEO 3" appear in sequence.



Note

- If you connect your VCR without a cable box, your PIP input source is a VCR. If you connect your VCR with a cable box, your PIP input source is a VCR or cable box.

Changing TV channels in the window picture

Press CH +/- in the PIP control area.



Listening to the sound of the window picture

Press AUDIO.

"b" appears for a few seconds, indicating that the window picture sound is being received.



To restore the main picture sound, press AUDIO again.

Changing the position of the window picture

Press POSITION.

Each time you press POSITION, the window picture will move as illustrated.



Freezing the window picture

This feature is useful when you want to write down a recipe from a cooking program, a displayed address or a phone number and so on.

Press FREEZE.



To restore the normal screen, press FREEZE again.

Swapping the main and window pictures

Press SWAP.

Each time you press SWAP, the images and sound from the main and window pictures switch places with another.

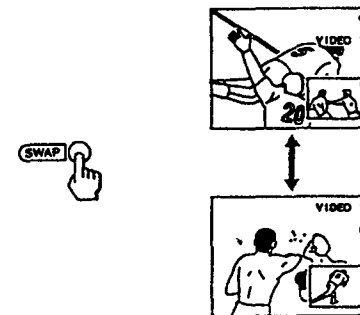

Note (KP-41T25 only)

- The channels being received through the AUX jack cannot be displayed as a window picture.

Selecting picture and sound effects (PROGRAM PALETTE)

You can select one of three settings for picture and sound effects that best suits the program. You can also adjust picture effect for each setting to suit your taste.

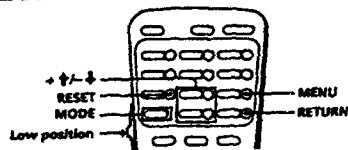

1 Press MENU.

2 Press +↑ or -↓ to select PROGRAM PALETTE and press RETURN.

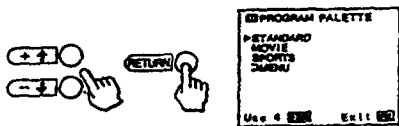

3 Select the item you want to adjust.

For example:
(1) To select MOVIE, press +↑ or -↓ to move the cursor to MOVIE.



(2) Press RETURN.



For details on each item, see "Effect of three items" in the right column.

Effect of three items

Item	Picture effect	Sound effect
STANDARD	Standard	Standard
MOVIE	Finely detailed picture	Theatrical audio effect
SPORTS	Vivid, bright picture	Sound with a sports stadium effect

Adjusting the picture in PROGRAM PALETTE

1 Press MENU.

2 Press +↑ or -↓ to select VIDEO and press RETURN.



3 Press +↑ or -↓ to select MODE and press RETURN.



4 Press +↑ or -↓ to select the item which you want to adjust and press RETURN.



5 Adjust the picture according to the steps 3 to 5 in "Adjusting the picture" on page 27.

To restore the factory setting
Press RESET while the VIDEO menu is displayed.

Adjusting the picture (VIDEO)

When watching TV programs, you can adjust the quality of the picture to suit your taste. The adjusted level is stored in PROGRAM PALETTE in which that adjustment is done. You can adjust the picture of video input(s) as well.

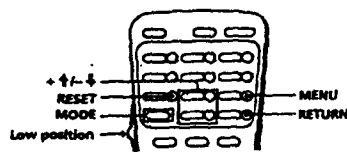

1 Press MENU.

2 Press +↑ or -↓ to move the cursor to VIDEO and press RETURN.
The VIDEO adjustment menu appears.

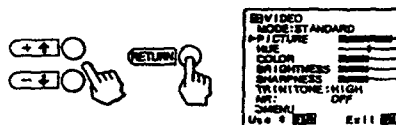

3 Select the item you want to adjust.

For example:
(1) To adjust brightness, press +↑ or -↓ to select BRIGHTNESS.



(2) Press RETURN.



4 Adjust the selected item:
(1) Press +↑ or -↓ to adjust the item.



(2) Press RETURN.

The new setting appears in the VIDEO menu, and is stored in the displayed PROGRAM PALETTE mode.



For details on each item, see "Description of adjustable items" below.

5 To adjust other items, repeat steps 3 and 4.

Description of adjustable items.

Item	Press +↑ to	Press -↓ to
PICTURE	Increase picture contrast for vivid color	Decrease picture contrast for soft color
HUE	Make overall picture greenish	Make overall picture purplish
COLOR	Increase color intensity	Decrease color intensity
BRIGHTNESS	Brighten the picture	Darken the picture
SHARPNESS	Sharpen the picture	Soften the picture

To restore the factory setting
Press RESET on the remote commander.

Adjusting the color temperature (TRINITONE)

The TRINITONE feature controls the color temperature, permitting white balance preference adjustment without affecting skin tones.

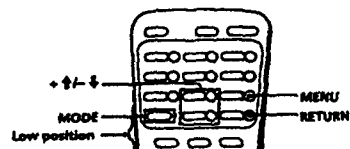

- 1 Press MENU.
- 2 Press +↑ or -↓ to select VIDEO and press RETURN.
- 3 Press +↑ or -↓ to select TRINITONE and press RETURN.

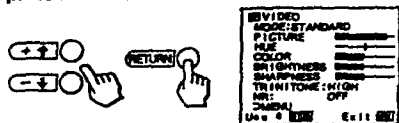

- 4 Press +↑ or -↓ to select NTSC STD, MEDIUM or HIGH and press RETURN.



Choose	To
NTSC STD	Make the white color reddish.
MEDIUM	Make the white color whitish.
HIGH	Make the white color bluish.

Reducing picture noise (NR)

You can reduce picture noise when NR is set to ON.

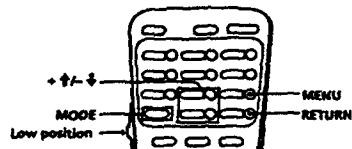

- 1 Press MENU.
- 2 Press +↑ or -↓ to select VIDEO and press RETURN.
- 3 Press +↑ or -↓ to select NR and press RETURN.



- 4 Press +↑ or -↓ to select ON and press RETURN.

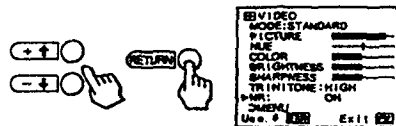

Note
• This feature is useful when watching a weak broadcast signal.

Adjusting sound (AUDIO)

You can adjust the quality of the TV sound to suit your taste. You can adjust the sound of video input(s) as well.

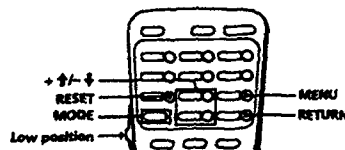

- 1 Press MENU.
- 2 Press +↑ or -↓ to select AUDIO and press RETURN.



- 3 Select the item you want to adjust.

For example:

- (1) To adjust bass, press +↑ or -↓ to select BASS.



- (2) Press RETURN.

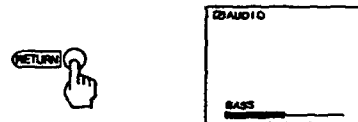

- 4 Adjust the selected item:
(1) Press +↑ or -↓ to adjust the item.



- (2) Press RETURN.
The new setting appears in the AUDIO menu.



For details on each item, see "Description of adjustable items" below.

- 5 To adjust other items, repeat steps 3 and 4 above.

Description of adjustable items

Item	Press +↑ to	Press -↓ to
TREBLE	Increase the treble response	Decrease the treble response
BASS	Increase the bass response	Decrease the bass response
BALANCE	Emphasize the right speaker's volume	Emphasize the left speaker's volume

To restore the factory settings
Press RESET on the remote commander.

Listening to surround sound (SURROUND)

The SURROUND feature simulates sound reproduction with the atmosphere of a movie theater or a concert hall. Surround sound is only effective for stereo programs (stereo light indication on).

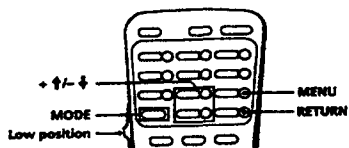

- 1 Press MENU.
- 2 Press + ↑ or - ↓ to select AUDIO and press RETURN.
- 3 Press + ↑ or - ↓ to select SURROUND and press RETURN.

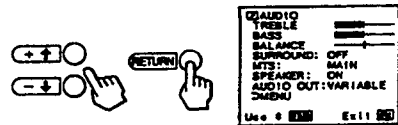

- 4 Press + ↑ or - ↓ to select ON and press RETURN.

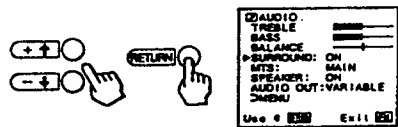

Selecting stereo or bilingual programs (MTS)

The Multichannel TV Sound (MTS) feature gives you the choice to enjoy stereo sound or Second Audio Programs (SAP) when available. The initial setting is stereo sound (MAIN).

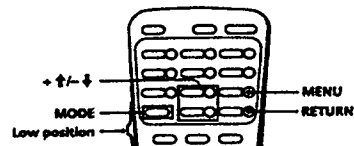

- 1 Press MENU.
- 2 Press + ↑ or - ↓ to select AUDIO and press RETURN.
- 3 Press + ↑ or - ↓ to select MTS and press RETURN.



- 4 Press + ↑ or - ↓ to select MAIN, SAP or MONO and press RETURN.

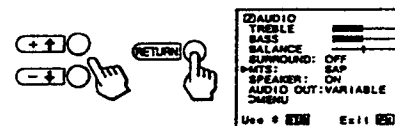

Choose	To
MAIN	Listen to stereo sound. The STEREO indicator on the projection TV lights up while a stereo broadcast is received.
SAP	Listen to bilingual programs. The sound of non-SAP programs will be muted when SAP is selected.
MONO	Reduce noise during stereo broadcasts.

Note
• Stereo and SAP sounds are subject to program sources.

Setting the speaker switch (SPEAKER)

You may switch off the projection TV speakers when, for example, you want to listen to the sound through a stereo system.

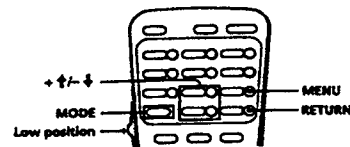

- 1 Press MENU.
- 2 Press + ↑ or - ↓ to select AUDIO and press RETURN.
- 3 Press + ↑ or - ↓ to select SPEAKER and press RETURN.

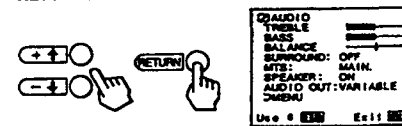

- 4 Press + ↑ or - ↓ to select OFF and press RETURN.

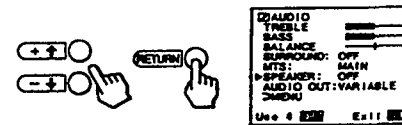

Setting audio out (AUDIO OUT)

You can select audio out to variable or fixed when SPEAKER is set to OFF. Audio out is variable when SPEAKER is set to ON.

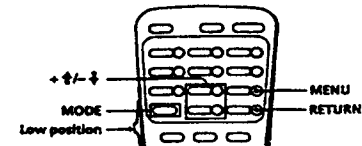

- 1 Press MENU.
- 2 Press + ↑ or - ↓ to select AUDIO and press RETURN.
- 3 Press + ↑ or - ↓ to select AUDIO OUT and press RETURN.

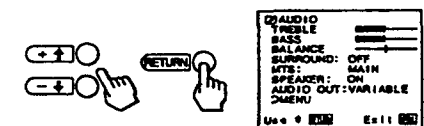

- 4 Press + ↑ or - ↓ to select VARIABLE or FIXED and press RETURN.

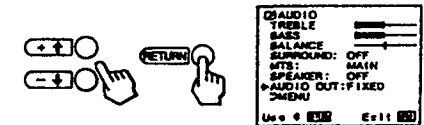

VARIABLE: Sound output varied according to the projection TV settings. You can adjust the volume, bass, treble and balance.
FIXED: Sound output is always fixed to a certain level. You cannot adjust the volume.

Setting daylight saving time (DAYLIGHT SAVING)

If your area uses daylight saving time, change DAYLIGHT SAVING setting depending on the season, before setting the current time.

Daylight saving start

- After the first Sunday in April, set DAYLIGHT SAVING to YES. Current time setting (page 33) automatically moves one hour ahead.

Daylight saving end

- After the last Sunday in October, set DAYLIGHT SAVING to NO. Current time setting automatically moves one hour back.

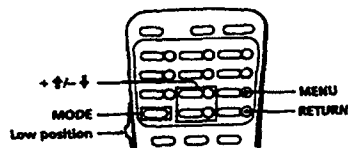

1 Press MENU.

2 Press + or - to move the cursor (▷) to TIMER/CH BLOCK and press RETURN.

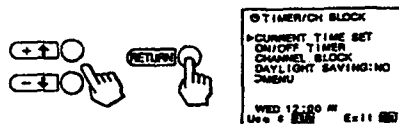

3 Press + or - to select DAYLIGHT SAVING and press RETURN.

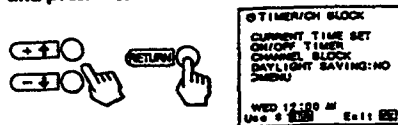

4 Press + or - to select YES or NO and press RETURN.

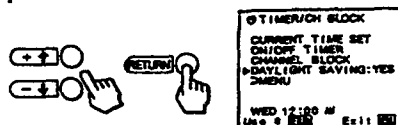

Choose	To
YES	Set for daylight saving start
NO	Set for daylight saving end

Setting the clock: (CURRENT TIME SET)

Set the current time before using On/off Timer (page 34) and Channel Block features (page 35). For example, set the clock to 3:15 p.m., Monday.

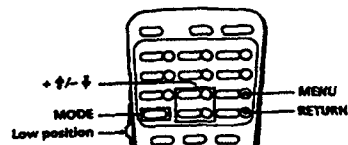

1 Press MENU.

2 Press + or - to select TIMER/CH BLOCK and press RETURN.

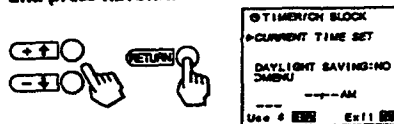

If you need to set DAYLIGHT SAVING, follow the procedure on the previous page.

3 Make sure the cursor (▷) is beside CURRENT TIME SET, and press RETURN.

If the cursor is not beside CURRENT TIME SET, press + or - to move the cursor and press RETURN.



4 Set the current time.

(1) Press RETURN to start setting the time.



(2) Press + or - to set the day and press RETURN.

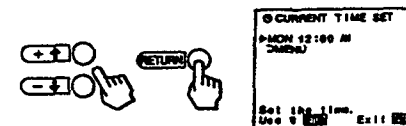

(3) Using + or - and RETURN, set hour and minute in the same way as in step (2). When you press RETURN after setting the minute, the clock starts.

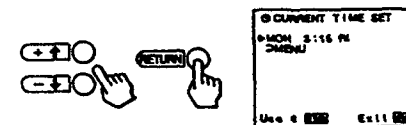

If you make a mistake while setting the time Press RESET while the CURRENT TIME SET menu is displayed, then repeat step 4.

To display the current time Press DISPLAY.

Note

- If you unplug the projection TV or a power interruption occurs, the clock will be erased. Reset the current time.

Setting the timer to turn the projection TV on and off (ON/OFF TIMER)

You can set the projection TV to turn on and off at the time you specify. Make sure the clock is set correctly. If it is not, set the clock first.

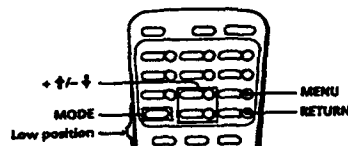

- 1 Press MENU.
- 2 Press +↑ or -↓ to select TIMER/CH BLOCK and press RETURN.
- 3 Press +↑ or -↓ to select ON/OFF TIMER and press RETURN.

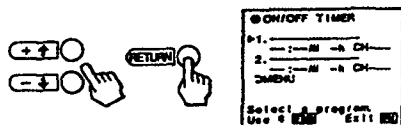

4 Enter the ON/OFF TIMER setting.

- (1) Press +↑ or -↓ to select program 1 or 2 and press RETURN.
- (2) Press +↑ or -↓ to set the days and press RETURN. Each time you press +↑ or -↓, the days cycle as shown below.
 EVERY SUN-SAT → EVERY MON-FRI → SUNDAY → MONDAY → ... → SATURDAY → EVERY SUNDAY → EVERY MONDAY → ... → EVERY SATURDAY

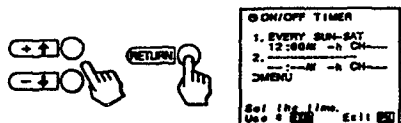

- (3) Press +↑ or -↓ to set the time (hour then minute) that you want to turn on the projection TV and press RETURN.

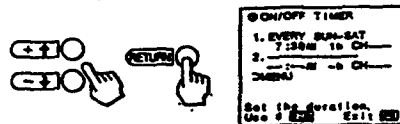

- (4) Press +↑ or -↓ to set the hour duration and press RETURN. You can set the hour duration by one hour up to a maximum of six hours.

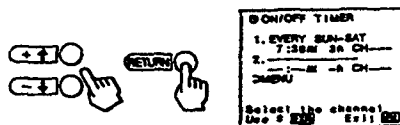

- (5) Press +↑ or -↓ to select the channel and press RETURN.

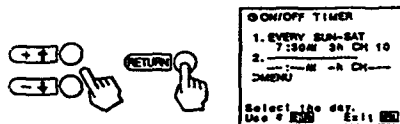

The TIMER/STAND BY indicator on the projection TV lights.

- 5 To set the other program, press RETURN and repeat step 4.

One minute before the projection TV switches to turn off, a message "TV will turn off." is displayed on the screen.

To cancel the timer

Press RESET on the remote commander.

Note

- If you unplug the projection TV or a power interruption occurs, ON/OFF TIMER settings will be erased. Reset the current time, then set the timer.

Blocking out a channel (CHANNEL BLOCK)

This feature allows you to prevent children from watching unsuitable programs. Make sure the clock is set correctly. If it is not, set the clock first (page 33).

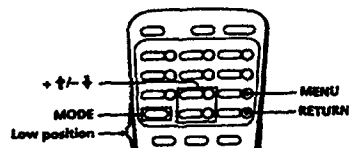

- 1 Press MENU.
- 2 Press +↑ or -↓ to select TIMER/CH BLOCK and press RETURN.
- 3 Press +↑ or -↓ to select CHANNEL BLOCK and press RETURN.

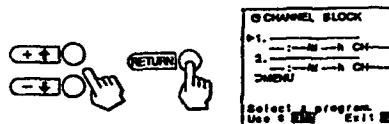

4 Enter a CHANNEL BLOCK setting.

- (1) Press +↑ or -↓ to select program 1 or 2 and press RETURN.
- (2) Press +↑ or -↓ to set the days and press RETURN. Each time you press +↑ or -↓, the days cycle as shown below.
 EVERY SUN-SAT → EVERY MON-FRI → SUNDAY → MONDAY → ... → SATURDAY → EVERY SUNDAY → EVERY MONDAY → ... → EVERY SATURDAY

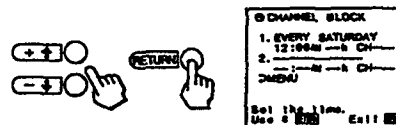

- (3) Press +↑ or -↓ to set the time (hour then minute) that you want to start blocking the channel and press RETURN.



- (4) Press +↑ or -↓ to select the hour duration you want to block and press RETURN. Each time you press RETURN, the hour duration increases by one hour up to a maximum of 12 hours.

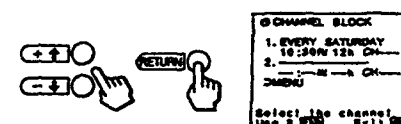

- (5) Press +↑ or -↓ to select the channel and press RETURN.

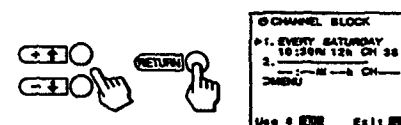

If you select the blocked channel during the time you set, the message "BLOCKED" appears and the picture is blocked and the sound is muted.

To cancel a CHANNEL BLOCK setting
Press RESET on the remote commander.

Note

- If the CHANNEL BLOCK and ON/OFF TIMER settings are overlapped, the later time setting has priority over the other setting.

Customizing the channel number buttons (CH CAPTION/GUIDE)

You can choose up to 12 channels, caption each channel, and assign a specific channel number button to each channel. This feature allows you to select your favorite channels easily by name. For example, you can name channel 20 "ESPN," and assign the channel number 4 button to it.

Setting captions to favorite channels

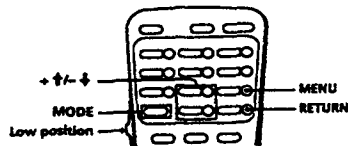

- 1 Press MENU.
- 2 Press + ↑ or - ↓ to select SET UP and press RETURN.
- 3 Press + ↑ or - ↓ to select CH CAPTION/GUIDE and press RETURN.

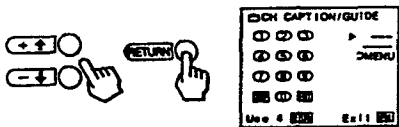

- 4 Press RETURN again.

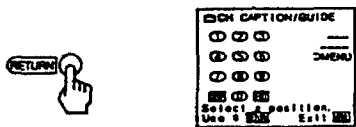

- 5 Press + ↑ or - ↓ to select a channel guide number button and press RETURN. Each time you press + ↑ or - ↓, the channel positions change to red in turns. The channel number button you select will be the one you press to call up your favorite channel.

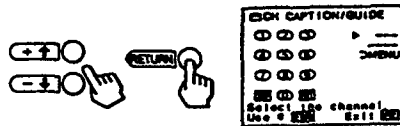

- 6 Press + ↑ or - ↓ to select the channel that you want to caption and press RETURN.

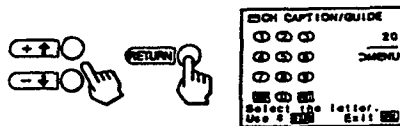

- 7 Enter the letters or numbers (up to four) to caption the channel:

- (1) Press + ↑ or - ↓ to select the first letter (number). Each time you press + ↑ or - ↓, the letter (number) changes as shown below.

0-1-2-3-4-5-6-7-8-9-A-B-C-D-E-F-G-H-I-J-K-L-M-N-O-P-Q-R-S-T-U-V-W-X-Y-Z- / - - - (blank space)



- (2) Press RETURN.

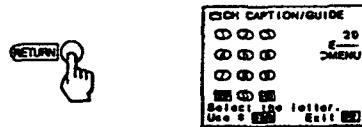

- (3) Repeat steps (1) and (2) to select the remaining letters (numbers) and press RETURN.

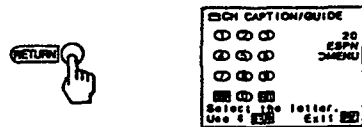

- 8 Repeat steps 4 to 7 to caption other channels.

To erase a caption Press RESET after step 4.

Notes

- The position number you already selected appears in yellow.
- If the CH CAPTION/GUIDE menu appears in black, the projection TV is set to a video input, and you cannot select CH CAPTION/GUIDE. Press TV so that a channel number appears.
- If more than 90 seconds elapse after you press a button, the menu disappears automatically.
- The channel caption feature is not available for the AUX input (KP-41T25 only).

Selecting a captioned channel

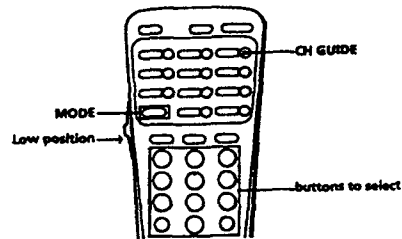

- 1 Press CH GUIDE. The CHANNEL GUIDE menu appears showing channel captions and the corresponding channel number buttons.

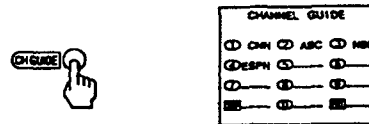

- 2 Press a channel number button, the DISPLAY or ENTER button to select the channel you want.

To cancel the CHANNEL GUIDE menu Press CH GUIDE again.

Setting video labels (VIDEO LABEL)

This feature allows you to label each input mode so that you can easily identify the connected equipment. For example, you can label VIDEO 1 IN as VHS.

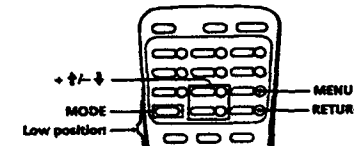

- 1 Press MENU.
- 2 Press + ↑ or - ↓ to select SET UP and press RETURN.
- 3 Press + ↑ or - ↓ to select VIDEO LABEL and press RETURN.

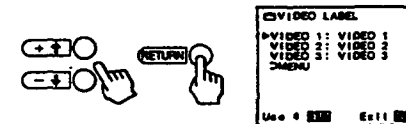

- 4 Press + ↑ or - ↓ to select the input mode you want to label and press RETURN.

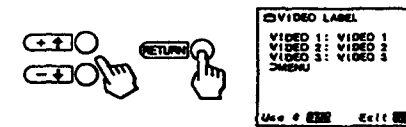

(continued)

5 Press + ↑ or - ↓ to select the label and press RETURN.



Each time you press + ↑ or - ↓, the label changes as shown below.

VIDEO 1
VIDEO 1 → S-VIDEO → BETA → 8mm → VHS → LD → DBS

VIDEO 2
VIDEO 2 → BETA → 8mm → VHS → LD → DBS

VIDEO 3
VIDEO 3 → BETA → 8mm → VHS → LD → DBS

6 Repeat steps 4 and 5 to label other input modes.

Note
• If more than 90 seconds elapse after you press a button, the menu disappears automatically.

Displaying Caption Vision (CAPTION VISION/ XDS)

Some programs are broadcast with Caption Vision. To display Caption Vision, select either CC1, CC2, CC3, CC4, TEXT1, TEXT2, TEXT3 or TEXT4 from the menu. CC1, CC2, CC3 or CC4 shows you a caption, that is a printed version of the dialog or sound effects of a program. (The mode should be set to CC1 for most programs.) TEXT1, TEXT2, TEXT3 or TEXT4 shows you text, that is information presented using either half or the whole screen. It is not usually related to the program.

1 Press MENU.

2 Press + ↑ or - ↓ to select CAPTION VISION/ XDS and press RETURN.

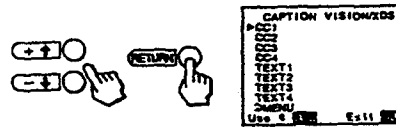

3 Press + ↑ or - ↓ to select the caption type and press RETURN.
The selected caption type is colored green.

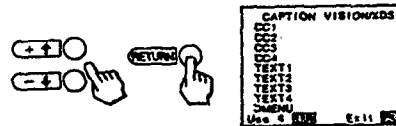

To turn off the captions or text
Press DISPLAY on the remote commander.
Each time you press DISPLAY, the display changes as follows:
on-screen information → XDS → Caption Vision or Text
DISPLAY OFF

DISPLAY OFF goes off after three seconds.

* Some programs are broadcast with XDS service which shows a network name, program name, program length, call letters and time of the show. When you select XDS with the DISPLAY button, this information will be displayed on the screen if the broadcaster offers this service.

Note
• Captions may appear with a white box or another error instead of a certain word. Poor reception of TV programs can also cause errors in Closed Caption.

Operating video equipment

You can operate a piece of video equipment that has an infrared remote sensor with the supplied remote commander. Before operating, set the manufacturer's code number.

Setting the manufacturer's code

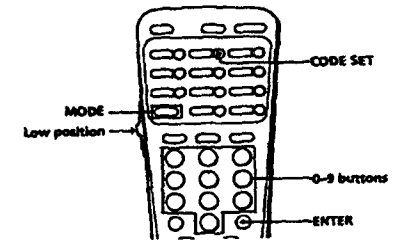

While holding down CODE SET, press 0 - 9 to enter the manufacturer's code number (see the chart on page 35) and press ENTER. For example, to operate a Sony 8 mm VCR, press 0, 2 and ENTER.



(continued)

Manufacturer code numbers

Manufacturer	Code number
SONY	01, 02, 03
CANON	05
EMERSON	22, 30, 33
FISHER	10, 11, 12, 15
FUNAI	29
GENERAL ELECTRIC	05, 08
GOLDSTAR	25
HITACHI	07, 08, 36
JVC	16, 35
MAGNAVOX	05, 06, 09
MITSUBISHI	18, 19, 26, 27
MULTITECH	29
NEC	16, 23, 31
PANASONIC	05, 06, 37
PHILCO	05, 06
PHILIPS	05, 06, 09
QUASAR	05, 06
RCA	07, 08
SAMSUNG	24, 32
SANYO	11, 15
SCOTT	21
SHARP	13, 14
SHINTOM	34
SYLVANIA	05, 06, 09
SYMPHONIC	29
TEKNIKA	28, 29
TOSHIBA	20, 21
TOTE VISION	25
ZENITH	17

MDP manufacturer code numbers

Manufacturer	Code number
SONY	04
KENWOOD	58
MAGNAVOX	52
MARANZ	54
MITSUBISHI	51
PANASONIC	55
PHILIPS	52
PIONEER	51
RCA	51
SANYO	57
SHARP	56
YAMAHA	53

Notes

- If more than one code number is listed, try entering them one by one, until you come to the correct code for your equipment.
- In some rare cases, you may not be able to operate your non-Sony video equipment with this remote commander. This is because your equipment may use a code that is not provided with this remote commander. In this case, please use the equipment's own remote control unit.
- The code numbers for Sony equipment are assigned at the factory as follows:

Beta, ED Beta VCRs	01
8 mm VCR	02
VHS VCR	03 (preset code for this remote commander)

Caution

When you remove a battery from the remote commander, the code may revert to 03. Reset the codes each time you replace the battery, if necessary.

Operating video equipment

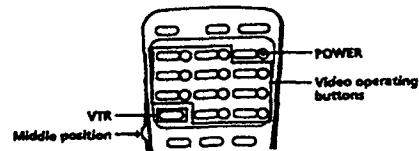

Use the video operating buttons on the remote commander to operate the video equipment.

Operating a VCR	Buttons on the remote commander
To turn on or off	Press POWER
To change channels	Press CH +/-
To record	Press ● and REC simultaneously
To play	Press ►
To stop	Press ■
To fast forward	Press ►►
To rewind the tape	Press ◄◄
To pause	Press
To search the picture forward and backward	Press ►► or ◄◄ during playback

Operating a laser-disc player	Buttons on the remote commander
To play	Press ►
To stop	Press ■
To pause	Press
To search the picture forward and backward	Keep pressing ►► or ◄◄ during playback To resume normal playback, release the button.
To search the chapter forward and backward	Press CH +/-

Note

- If the video equipment does not have a certain function, the corresponding button on this remote commander will not operate.

Operating a cable box

You can operate a connected cable box with the supplied remote commander. Before operating, set the manufacturer's code number.

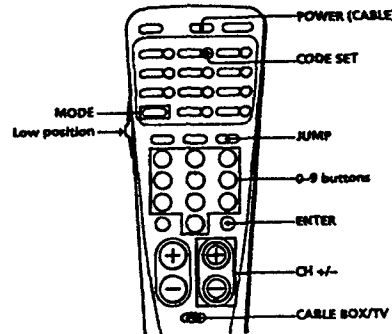

1 Set the CABLE BOX/TV selector to CABLE BOX.

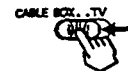

2 While holding down CODE SET, press 0 - 9 to enter the manufacturer's code number (see the chart in the right column) and press ENTER. For example, to operate a Zenith cable box, press 6 and 8 and press ENTER.



3 Use POWER (CABLE) and the projection TV control buttons (0 - 9, ENTER, JUMP and CH +/-) to operate the cable box.

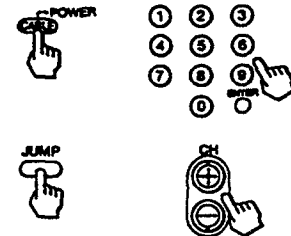

To operate the projection TV
Set the CABLE BOX/TV selector to TV. Then use the projection TV control buttons to control the projection TV.

For more details on operating the cable box
Refer to the operating instructions that come with the cable box.

Manufacturers and code numbers (cable box)

Manufacturer	Code number
JERROLD	60, 61, 62, 63, 64, 65, 73
PIONEER	69, 70
SCIENTIFIC ATLANTA	66, 67
TOCOM	71, 72
ZENITH	68

Notes

- If more than one code number is listed, try entering them one by one until you come to the correct code for your equipment.
- If you enter a new code number, the code number you previously entered at that setting is erased.
- In some rare cases, your equipment may use a code that is not provided with this remote commander and you may not be able to operate your cable box with the supplied remote commander. In this case, use the equipment's own remote control unit.
- When you remove a battery from the remote commander, the code may be erased. Reset the code each time you replace the battery, if necessary.

Troubleshooting

After trying the methods below, if the problem persists, contact your nearest Sony dealer.

No picture (screen not lit), no sound

- Make sure the power cord is connected securely.
- Check to see if the TV/VIDEO setting is correct: when watching TV, set to TV, and when watching video tapes, set to VIDEO. (page 24)
- Make sure the CABLE BOX/TV selector is in the correct position. (page 23)
- Try another channel. It could be station trouble.

Poor or no picture (screen lit), good sound

- Adjust PICTURE in the VIDEO menu. (page 27)
- Adjust BRIGHTNESS in the VIDEO menu. (page 27)
- Adjust the convergence. (page 20)
- Check antenna/cable connections. (page 6)

Good picture, no sound

- Press MUTING so that "MUTING" disappears from the screen. (page 23)
- Check the MTS setting in the AUDIO menu. (page 30)
- Make sure SPEAKER is set to ON in the AUDIO menu. (page 31)

No color

- Adjust COLOR in the VIDEO menu. (page 27)
- Confirm that black and white program is not being broadcast.

Only snow and noise appear on the screen

- Check the CABLE setting in the SET UP menu. (page 21)
- Check the antenna/cable connections. (page 6)
- Make sure the channel is broadcasting programs.

Dotted lines or stripes

- Adjust the antenna.
- Move the projection TV away from noise sources such as cars, neon signs, and hair-dryers.

Double images or ghosts

- Use a highly directional outdoor antenna or a cable (when the problem is caused by reflections from nearby mountains or tall buildings.)

Cannot operate menu

- If the item you want to choose appears in black, you cannot select it. Press TV/VIDEO correctly.
- Check the CABLE setting in the SET UP menu. (page 21)

Cannot receive upper channels (UHF) when using an antenna

- Check if CABLE is OFF in the SET UP menu. (page 21)
- Use AUTO PROGRAM to add receivable channels that are not presently in the memory. (page 22)

Cannot receive any channels when using cable TV

- Check if CABLE is ON in the SET UP menu. (page 21)
- Use AUTO PROGRAM to add receivable channels that are not presently in the memory. (page 22)

Remote commander does not operate

- Battery could be weak. Replace the battery. (page 17)
- Make sure the projection TV's power cord is connected securely to wall outlet.
- Set the CABLE BOX/TV selector to TV when operating your projection TV.
- Are fluorescent lights too close to the projection TV? Move lights at least 3 - 4 feet away from the projection TV.

Commander's power, channel up/down, channel buttons do not function

- Set the CABLE BOX/TV selector to the correct position. (page 41)

Cannot gain enough volume when using a cable box

- Increase the volume at the cable box. Then set the CABLE BOX/TV selector to TV and adjust the projection TV's volume. (page 41)

SECTION 2 DISASSEMBLY

2-1-1. REAR PLATE REMOVAL (KP-41T25)

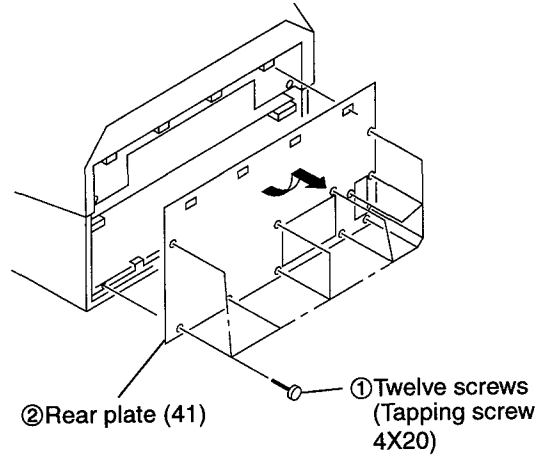

2-1-2. REAR PLATE REMOVAL (KP-46S25/53S25)

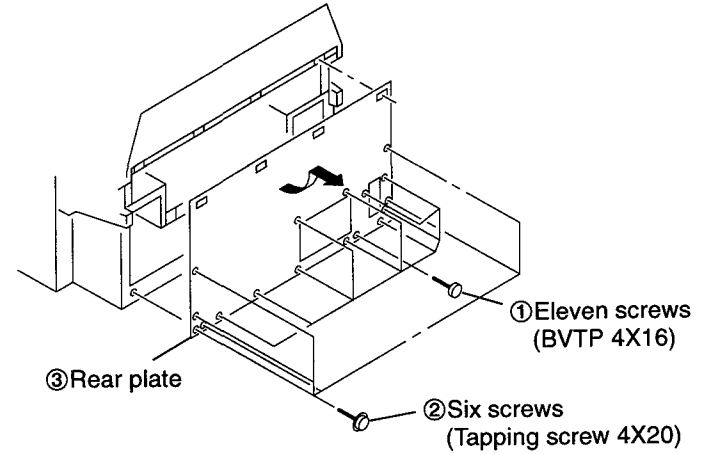

2-2. CHASSIS ASSY REMOVAL

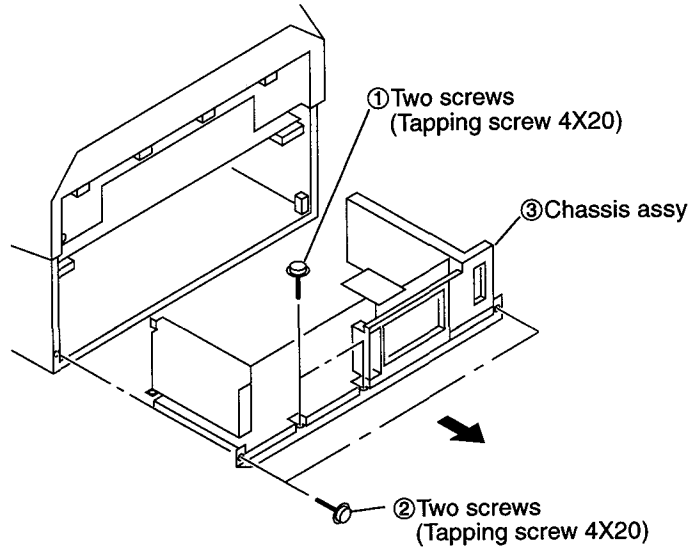

2-3. SERVICE POSITION

· Remove the chassis assy (Refer to 2-2.)

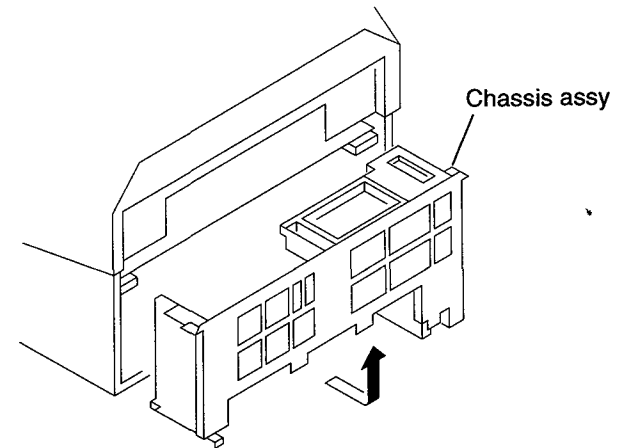

2-4. G BOARD REMOVAL

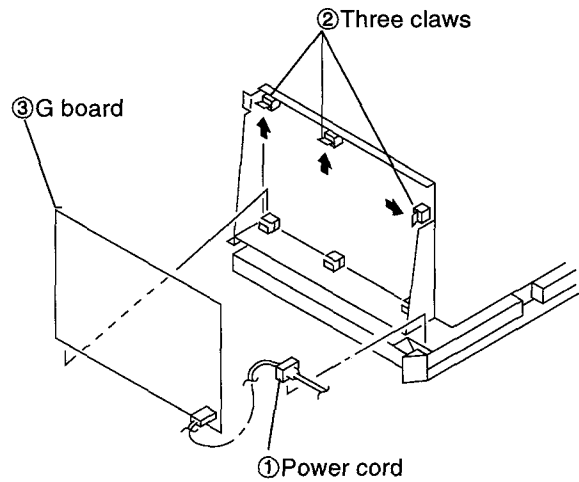

2-5. D BOARD REMOVAL

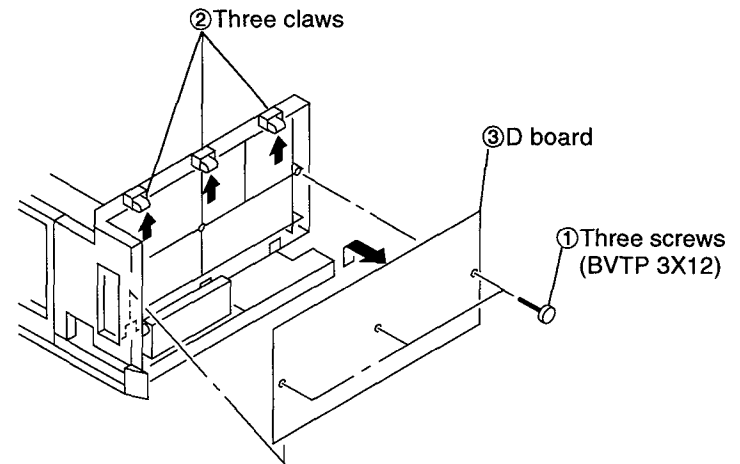

2-6. U BOARD REMOVAL

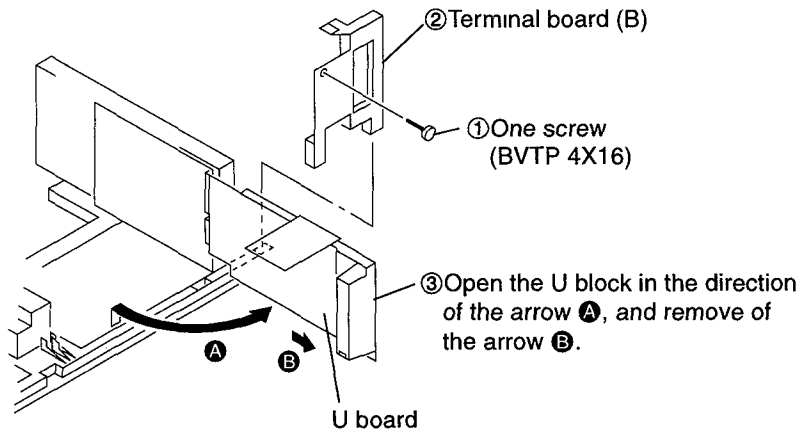

2-7. M BOARD REMOVAL

- 1 Remove the D board. (Refer to 2-5.)
- 2 Remove the U board. (Refer to 2-6.)

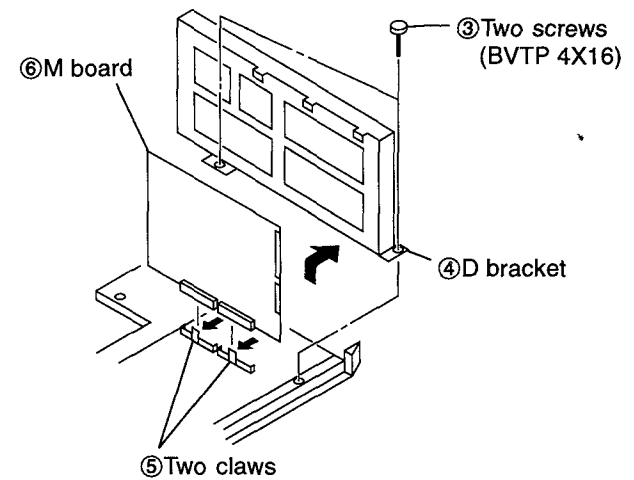

**2-8-1. HA BOARD REMOVAL
(KP-41T25)**

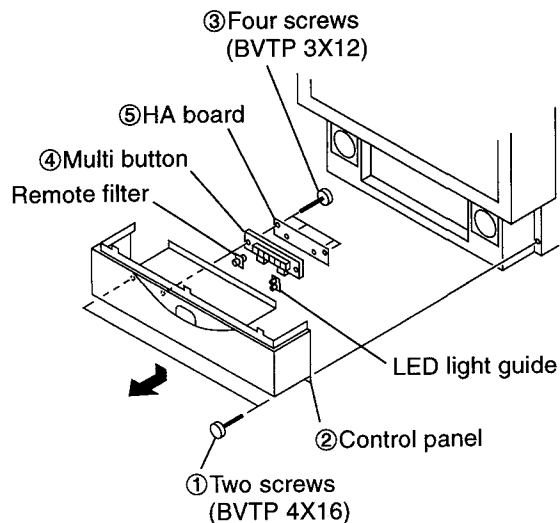

**2-8-2. HA BOARD REMOVAL
(KP-46S25/53S25)**

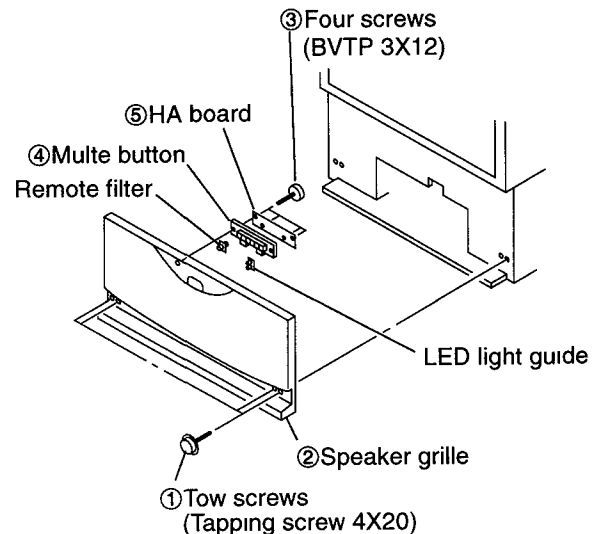

**2-9-1. BEZNET REMOVAL
(KP-41T25)**

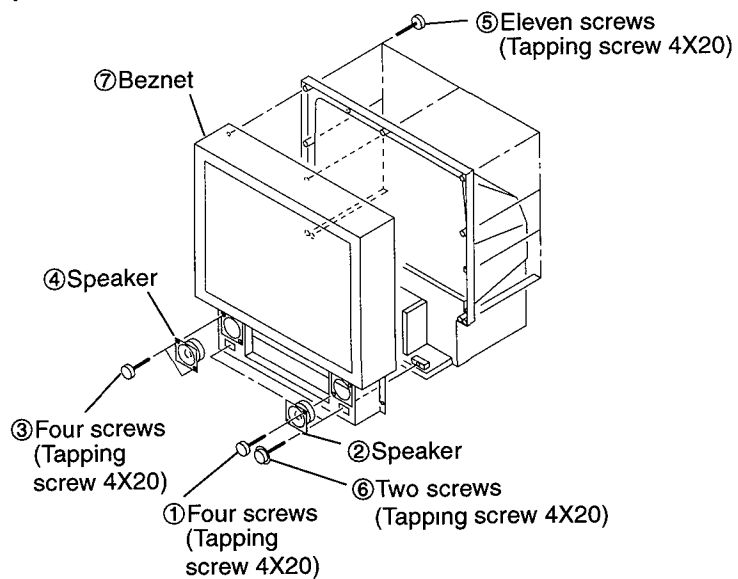

**2-9-2. BEZNET REMOVAL
(KP-46S25/53S25)**

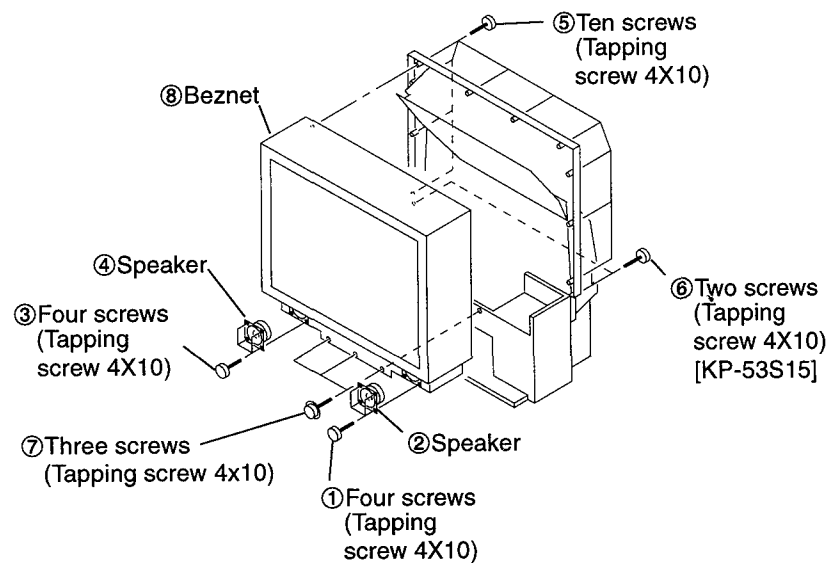

**2-10-1. MIRROR COVER REMOVAL
(KP-41T25)**

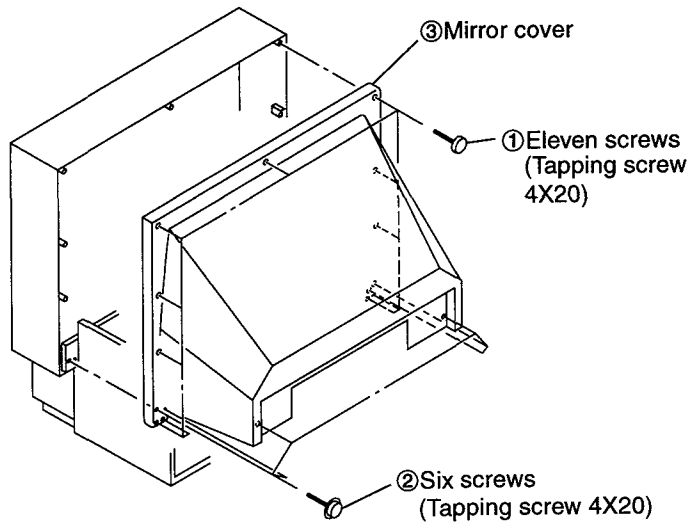

**2-10-2. MIRROR COVER REMOVAL
(KP-46S25/53S25)**

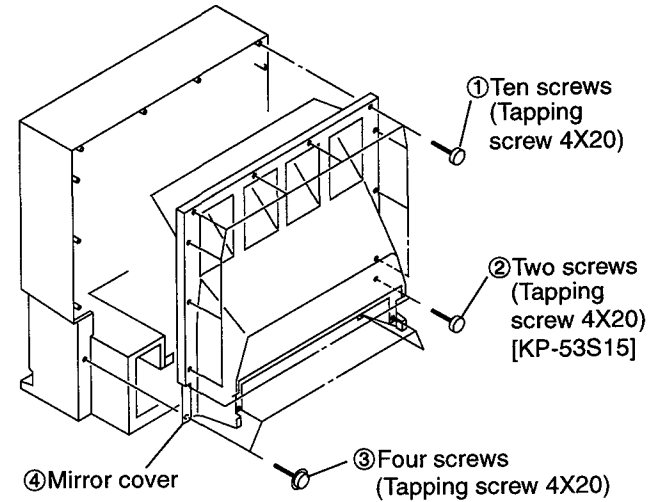

2-11. HIGH-VOLTAGE CABLE INSTALLATION AND REMOVAL

(1) Remover

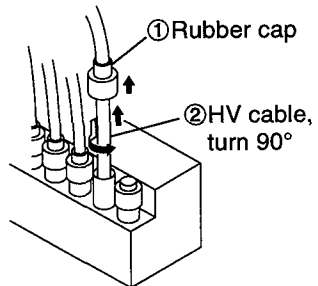

(2) Installation

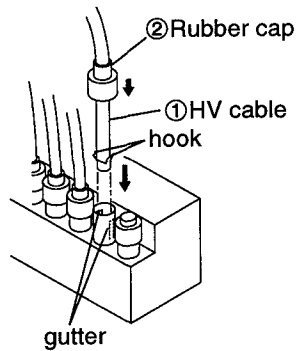

2-12. PICTURE TUBE REMOVAL

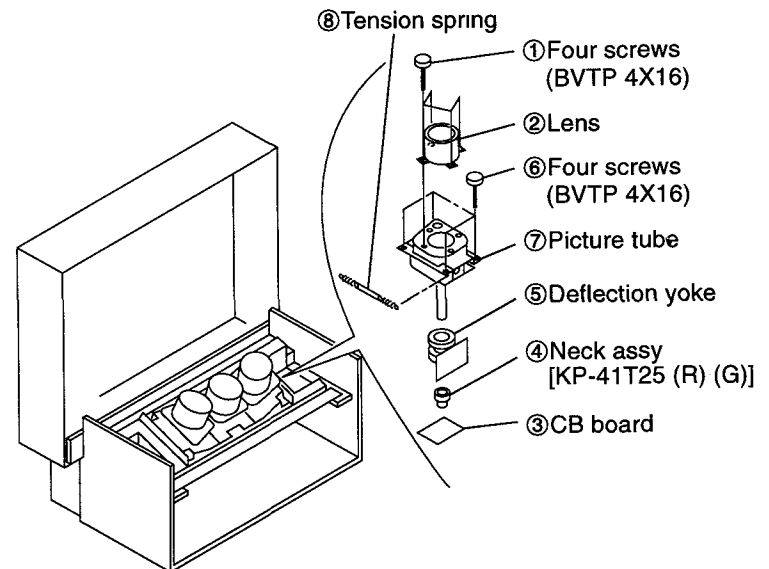

SECTION 3 SAFETY RELATED ADJUSTMENTS

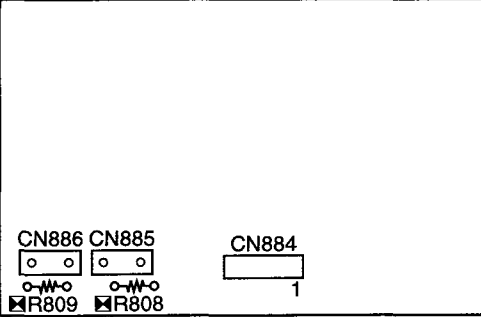
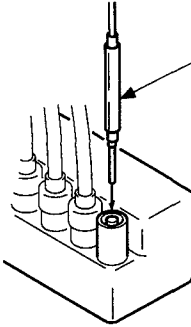
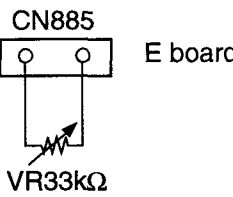
ADJUSTMENT ITEM AND PROCEDURE	EQUIPMENT AND SIGNAL	MEASUREMENT POSITION	ADJUSTMENT LOCATION	ILLUSTRATION AND SHAPE AND NUMBER
<div style="border: 1px solid black; padding: 5px; margin-bottom: 10px;"> HV HOLD DOWN CIRCUIT OPERATIONS CHECK AND ADJUSTMENT (*<input checked="" type="checkbox"/> RESISTOR) </div> <p>When replacing the parts marked *<input checked="" type="checkbox"/> on the right, check the HV hold down and adjust.</p> <ol style="list-style-type: none"> 1. Remove the cap for the unconnected pin in the *high-voltage block and connect a *Static Voltmeter meter. 2. Input 130 VAC power. 3. Receive the *Dot signal and set the *PICTURE and BRIGHTNESS settings to their minimums. 4. Connect a *33 kΩ variable resistor across the E board *CN885 connector (with the variable resistor set to its maximum). 	<p>*Static Voltmeter</p> <p>*Dot pattern</p>	<p>*<input checked="" type="checkbox"/> marked parts C818, D804, D806, D809, D909, D912, Q915, R809, R855, R856, R857, R858, R954, R955, R983, R984, R988, R991, R995, R996, R998, T801, T803 FBT E board HV Block</p> <p>*HV Block</p>	<p>*<input checked="" type="checkbox"/> R809, R988</p> <p>*PICTURE minimum BRIGHTNESS minimum</p>	<p style="text-align: center;">E BOARD – COMPONENT SIDE –</p> <div style="border: 1px solid black; padding: 10px; margin-bottom: 10px;">  </div> <p>*  Remove the cap off from the unused terminal and connect a static voltmeter there.</p> <p>*  E board</p>

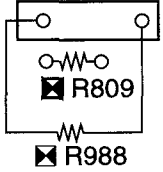
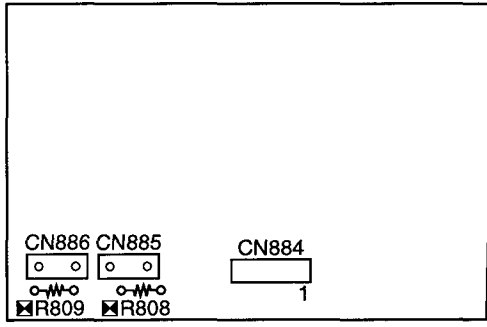
ADJUSTMENT ITEM AND PROCEDURE	EQUIPMENT AND SIGNAL	MEASUREMENT POSITION	ADJUSTMENT LOCATION	ILLUSTRATION AND SHAPE AND NUMBER
<p>5. Gradually lower the value of the variable resistor and check that the hold down circuit operates at a Static Voltmeter reading of *33.7 ± 0.75 kVDC and that the rasters disappear.</p> <p>6. If the hold down circuit operates and the rasters disappear at a Static Voltmeter reading of *34.45VDC or higher, remove resistor *R809 and mount a *16.0 kΩ 1/4W RN at *R988. If hold-down can not be adjusted to specification using a 16.0 kΩ resistor, use a 13.0 kΩ resistor. If the hold down circuit operates and the rasters disappear at a Static Voltmeter reading of *32.9 VDC or lower, remove resistor R809 and mount *6.2 kΩ 1/4W RN at *R988.</p> <p>7. Check Item 5 again.</p> <div style="border: 1px solid black; padding: 5px; width: fit-content;"> <p>HV REGULATION CIRCUIT CHECK AND ADJUSTMENT (*<input checked="" type="checkbox"/> RESISTOR)</p> </div> <p>When replacing the parts marked *<input checked="" type="checkbox"/> on the right, check the HV regulation and adjust.</p> <p>1. Remove the cap for the unconnected pin in the *high-voltage block and connect a *Static Voltmeter.</p> <p>2. Input 120 VAC power.</p> <p>3. Receive the *Dot signal and set the *PICTURE and BRIGHTNESS settings to their minimums.</p>	<p>*Static Voltmeter</p> <p>*Dot pattern</p>	<p>*<input checked="" type="checkbox"/> marked parts C918, C930, C934, C980, D902, D920, D925, Q909, R808, R851, R929, R936, R939, R942, R944, R945, R946, R947, R950, R960, R965, R967, R971, R975, R976, R982, R983, R985, R998 E Board HV Block *HV Block</p>	<p>*R988</p> <p>*R988</p> <p>*<input checked="" type="checkbox"/> R808, R983</p> <p>*PICTURE minimum BRIGHTNESS minimum</p>	<p>*33.7 ± 0.75 kVDC</p> <p>*34.45 VDC or higher * CN886 (E board)</p> <p>*16.0 kΩ 1/4W</p> <p>*32.95 VDC or lower</p> <p>*6.2 kΩ 1/4W</p>  <p>E BOARD – COMPONENT SIDE –</p> 

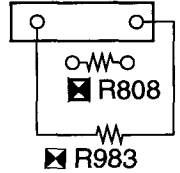
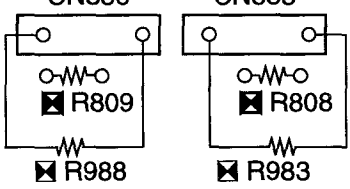
ADJUSTMENT ITEM AND PROCEDURE	EQUIPMENT AND SIGNAL	MEASUREMENT POSITION	ADJUSTMENT LOCATION	ILLUSTRATION AND SHAPE AND NUMBER
<p>4. Check that the Static Voltmeter reading is $*31.0^{+0.45}_{-0.65}$ kVDC.</p> <p>5. If the Static Voltmeter reading is $*30.4$ kV or lower, remove resistor $*R808$ and mount $*5.6$ kΩ 1/4W RN at $*R983$.</p> <p>6. If the Static Voltmeter reading is $*31.4$ KV or higher, remove resistor $*R808$ and mount $*8.2$ kΩ 1/4W RN at $*R983$.</p> <p>7. If the Static Voltmeter reading is $*32.0$ kV or higher, remove resistor $*R808$ and mount $*10.0$ kΩ 1/4W RN at $*R983$.</p> <p>8. If any of Items 5, 6 or 7 has been implemented, check Item 4 again.</p> <div style="border: 1px solid black; padding: 5px; margin: 10px 0;"> <p>HV HOLD DOWN AND HV REGULATOR SIMPLE ADJUSTMENT</p> </div> <p>It is normally desirable that the HV hold down and HV regulation checks use a high-voltage meter. However, sometime one is not available, for example in the field, below is a simple adjustment method.</p> <p>When replacing parts with the \blacksquare mark, replace both the resistors with the \boxtimes mark $*R808$ (R988) and $*R809$ (R983) with resistors one rank lower in the E-12 series. Do not replace just one of these resistors! Always replace both with resistors one rank lower.</p>			<p>$*R983$</p> <p>$*R983$</p> <p>$*R983$</p> <p>$*R808$ (R988)</p> <p>$*R809$ (R983)</p>	<p>$*31.0^{+0.45}_{-0.65}$ kVDC $*30.4$ kV or lower $*5.6$ kΩ 1/4W $*31.4$ KV or higher $*8.2$ kΩ 1/4W $*32.0$ kV or higher $*10.0$ kΩ 1/4W</p> <p style="text-align: right;">* CN885 (E board)</p>  <p style="text-align: center;">* E board</p> 

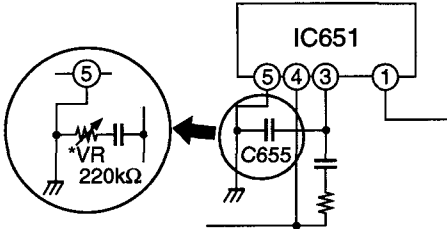
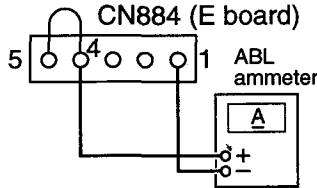
ADJUSTMENT ITEM AND PROCEDURE	EQUIPMENT AND SIGNAL	MEASUREMENT POSITION	ADJUSTMENT LOCATION	ILLUSTRATION AND SHAPE AND NUMBER
<p>OVERVOLTAGE PROTECTION (OVP) OPERATIONS CHECK</p> <ol style="list-style-type: none"> 1. Connect a *220 kΩ variable resistance rheostat to the G board C655 (between Pins ③ and ⑤ of IC651). 2. Input *120.0 ± 1.0 VAC, 60 Hz power. 3. Receive the *Dot signal and set the *PICTURE and BRIGHTNESS settings to their minimums. 4. Gradually lower the value of the connected variable resistance and check that when the +B line *voltage is *143.5 ± 5.5 VDC, the overvoltage circuit operates and the rasters disappear. 5. Remove the variable resistor and check the +B line voltage. 	<p>*Dot pattern</p> <p>*Digital Multimeter</p>		<p>*PICTURE minimum BRIGHTNESS minimum</p>	<p>* </p> <p>* 120.0 ± 1.0 VAC, 60 Hz</p> <p>* 143.5 ± 5.5 VDC</p>
<p>BEAM CURRENT (ΣIk) PROTECTION CIRCUIT CHECK</p> <ol style="list-style-type: none"> 1. Connect the *ABL ammeter between *Pins ① and ④ of the CN884 on the E board. Have Pins ② and ③ open. 2. Input *120.0 ± 1.0 VAC, 60 Hz power. 3. Receive a *monoscope signal and set the *PICTURE and BRIGHTNESS settings to their minimums. 	<p>*Ammeter</p> <p>*Monoscope pattern</p>		<p>*PICTURE minimum BRIGHTNESS minimum</p>	<p>* </p> <p>* 120.0 ± 1.0 VAC, 60 Hz</p>

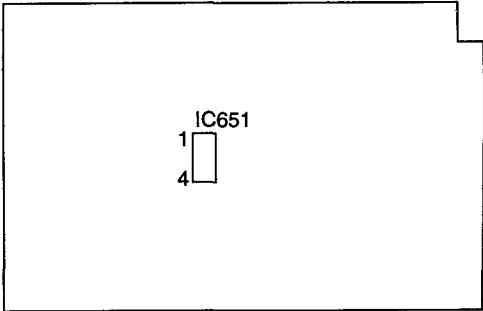
ADJUSTMENT ITEM AND PROCEDURE	EQUIPMENT AND SIGNAL	MEASUREMENT POSITION	ADJUSTMENT LOCATION	ILLUSTRATION AND SHAPE AND NUMBER
<p>4. Gradually raise the *PICTURE and BRIGHTNESS settings and check that below an *ABL current of 3.35 mA (including dark current), the beam current protection circuit operates and the rasters disappear.</p> <div style="border: 1px solid black; padding: 2px; width: fit-content; margin: 10px 0;"> <p>+B, +B MAX CHECK</p> </div> <p>When replacing the G board IC651, check the following.</p> <ol style="list-style-type: none"> 1. Input $*120.0 \pm 1.0$ V, 60 Hz power. 2. Receive the *Dot signal and set the *PICTURE and BRIGHTNESS settings to their minimums. 3. Check that the *+B line voltage is now $*135.0 \pm 2.0$ VDC. 4. Set the power supply to $*130.0^{+2.0}_{-0}$ VAC. 5. Check that the *+B line voltage is $*137.0$ VDC max. 6. If either 3 or 5 is not satisfied, replace IC651 again. 	<p>*Dot pattern</p>	<p>*CN681 pin ①</p> <p>*CN681 pin ①</p>	<p>*PICTURE BRIGHTNESS</p> <p>..... minimum</p> <p>BRIGHTNESS</p> <p>..... minimum</p>	<p>*Less than 3.35 mA</p> <p>E BOARD – COMPONENT SIDE –</p>  <p>*120.0 ± 1.0 V, 60 Hz</p> <p>*135.0 ± 2.0 VDC</p> <p>*130.0^{+2.0}₋₀ VAC</p> <p>*Less than 137.0 VDC</p>

SECTION 4 DIAGRAMS

4-1. CIRCUIT BOARDS LOCATION

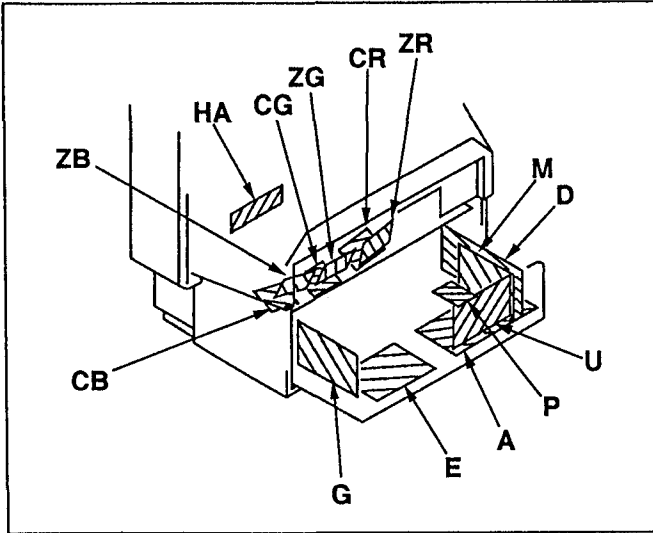

4-2. PRINTED WIRING BOARD AND SCHEMATIC DIAGRAMS

Note :

- All capacitors are in μF unless otherwise noted. $\text{pF} : \mu\mu\text{F}$ 50WV or less are not indicated except for electrolytics and tantalums.
- All resistors are in ohms.
 $\text{k}\Omega = 1000 \Omega$, $\text{M}\Omega = 1000\text{k}\Omega$
- Indication of resistance, which does not have one for rating electrical power, is as follows.

Pitch : 5mm

Rating electrical power : $\frac{1}{4}\text{W}$

- : nonflammable resistor.
- : fusible resistor.
- Δ : internal component.
- : panel designation and adjustment for repair.
- All variable and adjustable resistors have characteristic curve B, unless otherwise noted.
- : earth-chassis.
- The components identified by in this basic schematic diagram have been carefully factory-selected for each set in order to satisfy regulations regarding X-ray radiation. Should replacement be required, replace only with the value originally used.
- When replacing components identified by , make the necessary adjustments indicated. If results do not meet the specified value, change the component identified by and repeat the adjustment until the specified value is achieved.
(Refer to R808, R809, R983 and R988 adjustment on Page 29 - 33)
- When replacing the part in below table, be sure to perform the related adjustment.

Part replaced ()	Adjustment ()
HVBlock Q915, D804, D806, D809, D909, D912, C818, R809, R855, R856, R857, R858, R954, R955, R983, R984, R988, R991, R995, R996, R998, T801(FBT), T803 E BOARD	HV HOLD-DOWN (R809, R988)
HV Block, Q909, D902, D920, D925, C918, C930, C980, R808, R851, R929, R936, R939, R942, R944, R945, R946, R947, R950, R960, R965, R967, R971, R975, R976, R982, R983, R985, R998.... E BOARD	HV Reagurator (R808, R983)

Reference information

RESISTOR	: RN	METAL FILM
	: RC	SOLID
	: FPRD	NONFLAMMABLE CARBON
	: FUSE	NONFLAMMABLE FUSIBLE
	: RW	NONFLAMMABLE WIREWOUND
	: RS	NONFLAMMABLE METAL OXIDE
	: RB	NONFLAMMABLE CEMENT
	: *	ADJUSTMENT RESISTOR
COIL	: LF-8L	MICRO INDUCTOR
CAPACITOR	: TA	TANTALUM
	: PS	STYROL
	: PP	POLYPROPYLENE
	: PT	MYLAR
	: MPS	METALIZED POLYESTER
	: MPP	METALIZED POLYPROPYLENE
	: ALB	BIPOLAR
	: ALT	HIGH TEMPERATURE
	: ALR	HIGH RIPPLE

- As to the voltage value shown by the semiconductors on the Schematic Diagram, see the another list.
- Readings are taken with a color-bar signal input.
- Readings are taken with a 10M Ω digital multimeter.
- Voltages are dc with respect to ground unless otherwise noted.
- Voltage variations may be noted due to normal production tolerances.
- All voltages are in V.
* : Measurement impossibility.
- Circled numbers are waveform references.
- : B + bus.
- : B - bus.
- : signal path.(RF)

Note: The symbol display is on the component side.

The components identified by shading and mark Δ are critical for safety. Replace only with part number specified.

The symbol indicate fast operating fuse. Replace only with fuse of same rating as marked.

Note: Les composants identifiés par un tramé et une marque Δ sont critiques pour la sécurité. Ne les remplacer que par une pièce portant le numéro spécifié.

Le symbole indique une fusible à action rapide. Doit être remplacée par une fusible de même valeur, comme marqué.

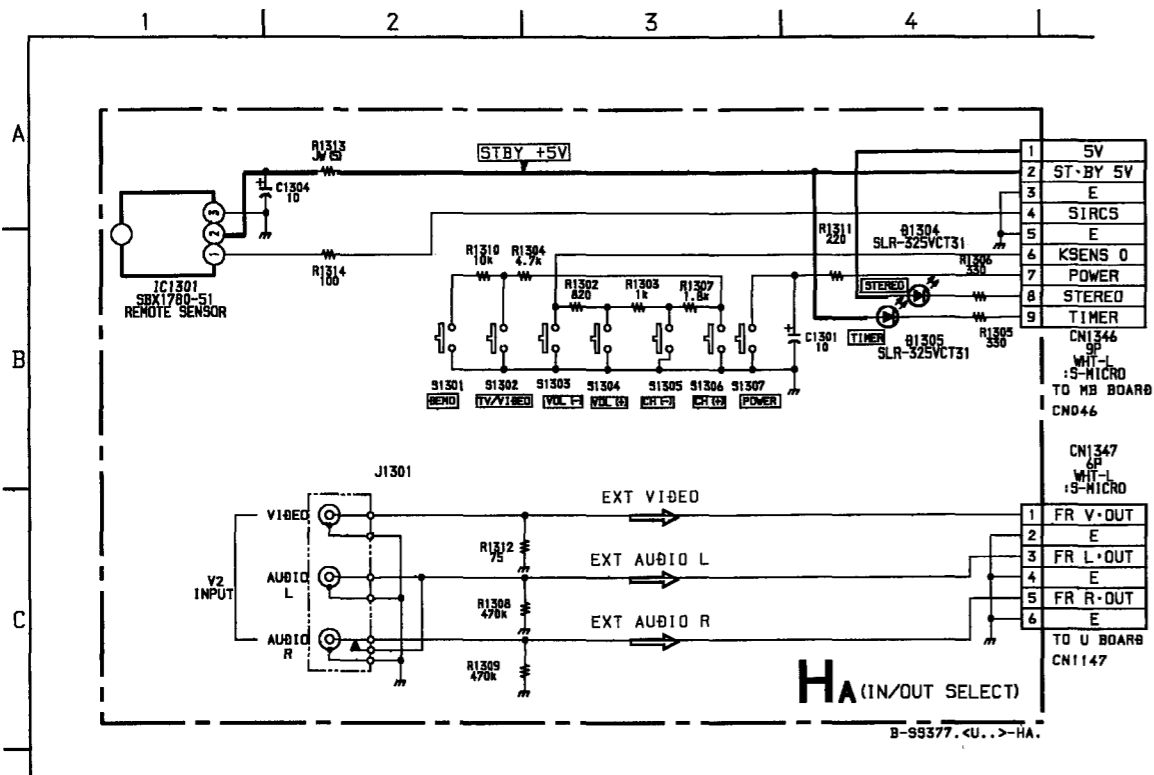

HA [IN/OUT SELECT]

- HA BOARD -

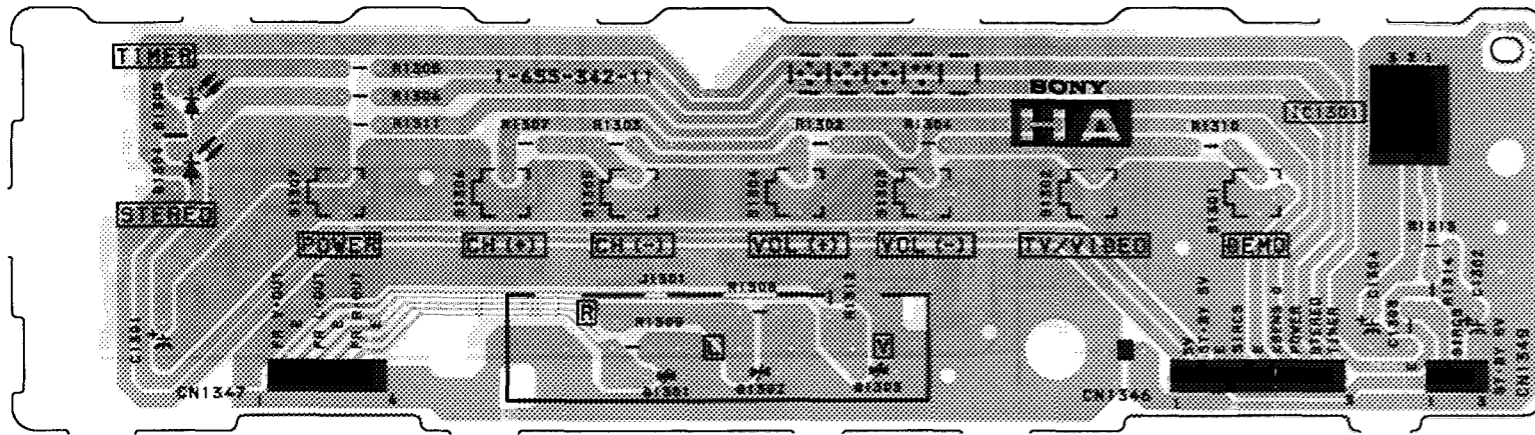

5V
 BY 5V
 E
 IRCS
 E
 ENS 0
 OMER
 ERED
 IMER
 N1346
 6B
 HT-L
 MICRO
 MB BOARD
 146

N1347
 6B
 HT-L
 MICRO
 V-OUT
 E
 L-OUT
 E
 R-OUT
 E
 U BOARD
 147

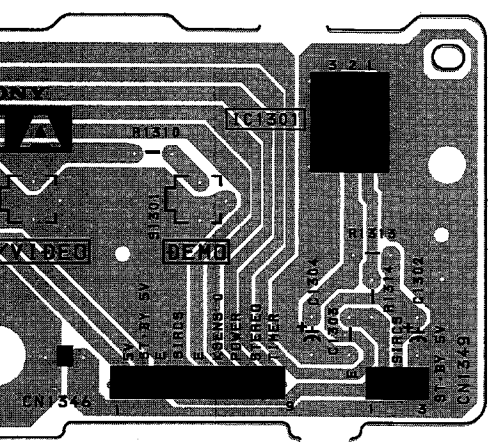

Schematic diagrams

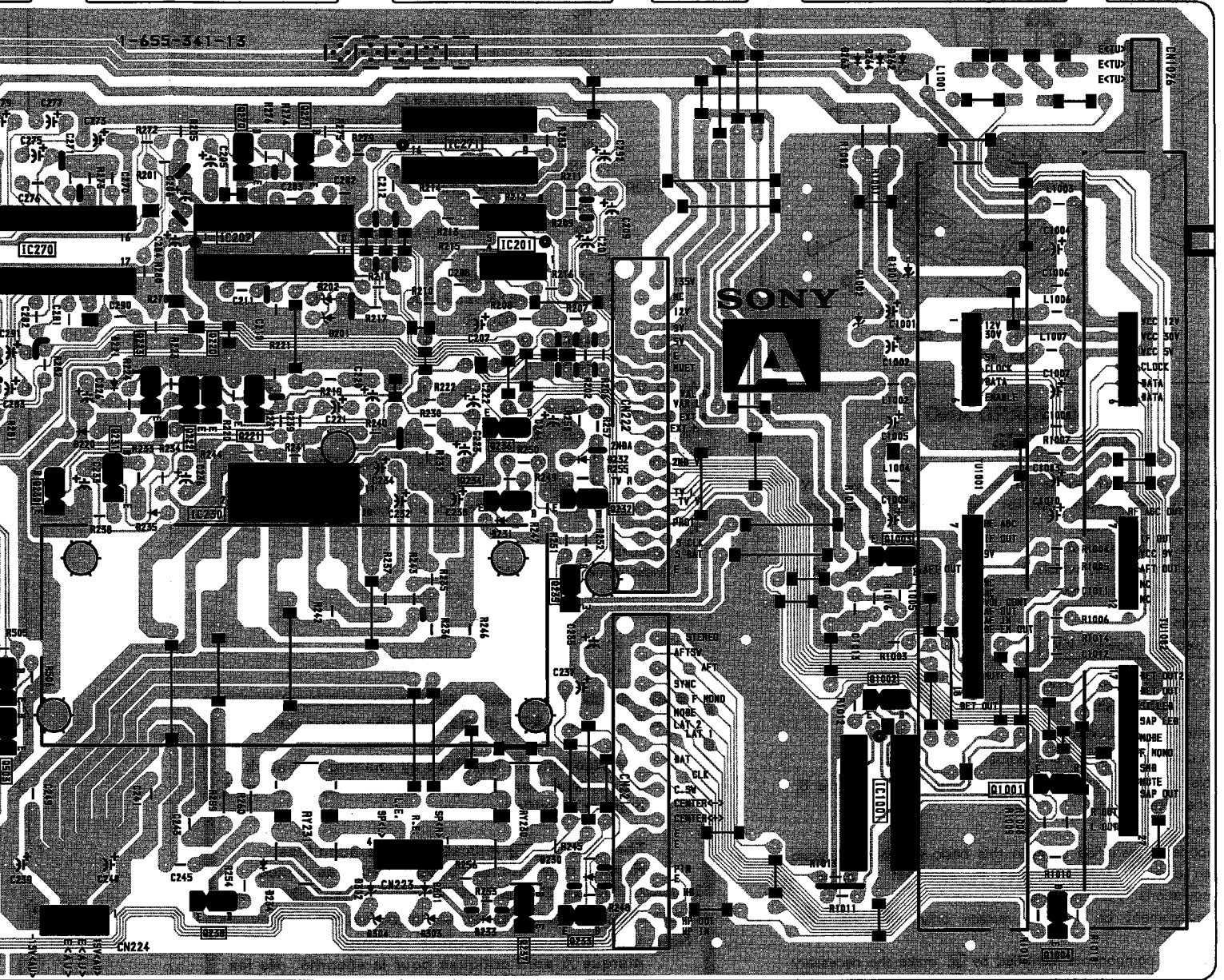

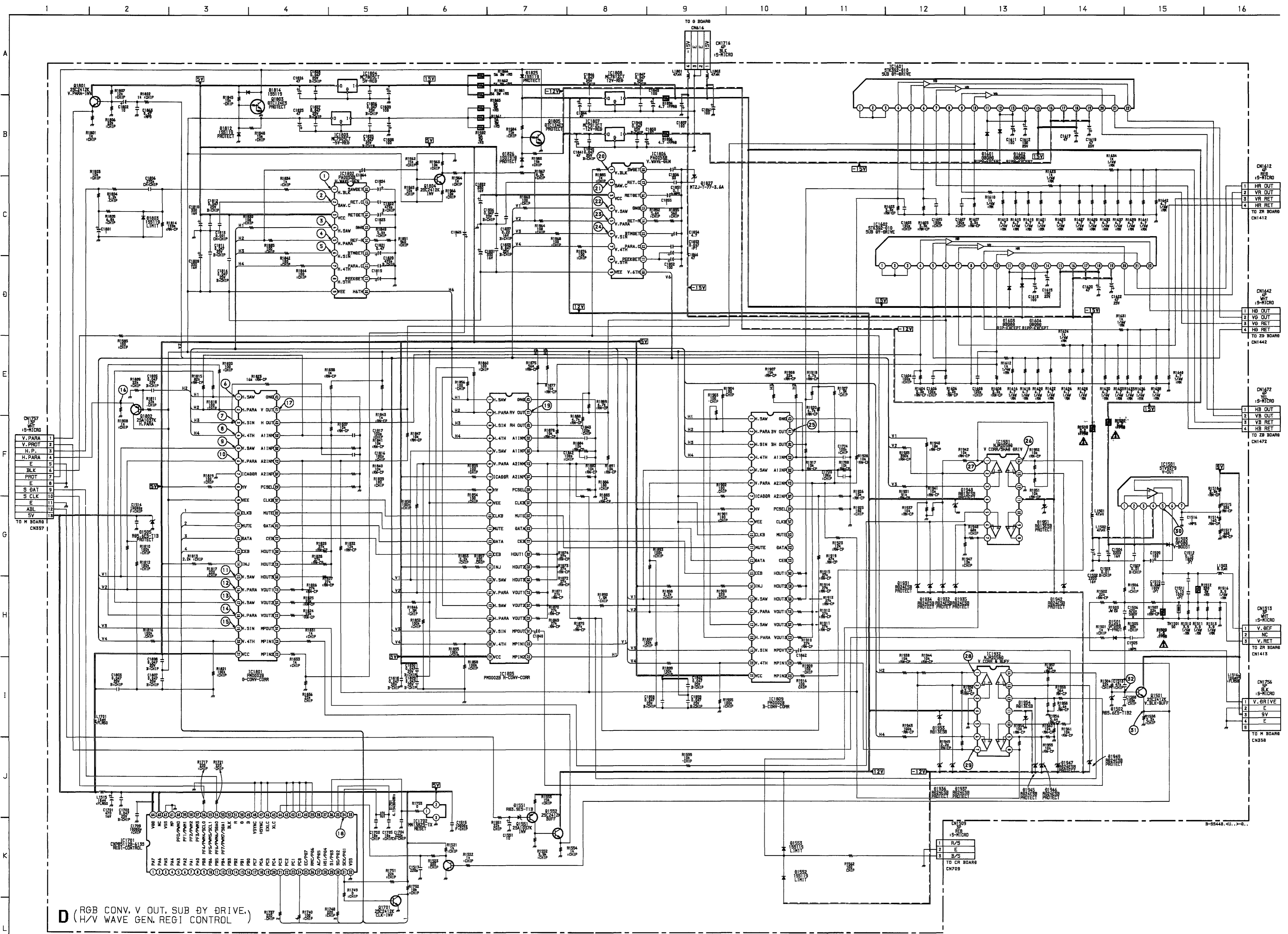

TO N BOARD CN557

1	V. PARA
2	V. PROT
3	H. P.
4	H. PARA
5	E
6	BLK
7	PROT
8	E
9	S DAT
10	S CLK
11	E
12	ABL
13	5V

TO ZR BOARD CN142

1	HR OUT
2	VR OUT
3	VR RET
4	HR RET

TO ZR BOARD CN142

1	HG OUT
2	VG OUT
3	VG RET
4	HG RET

TO ZR BOARD CN142

1	HB OUT
2	VB OUT
3	VB RET
4	HB RET

TO ZR BOARD CN145

1	V. BEF
2	NC
3	V. RET

TO N BOARD CN558

1	V. BRIVE
2	E
3	5V
4	E
5	E

TO CR BOARD CN709

1	R/S
2	E
3	B/S

D (RGB CONV. V OUT, SUB BY DRIVE, H/V WAVE GEN, REG1 CONTROL)

D RGB CONV, V OUT,
SUB DY DRIVE, H/V WAVE,
REGI CONTROL

- D BOARD -

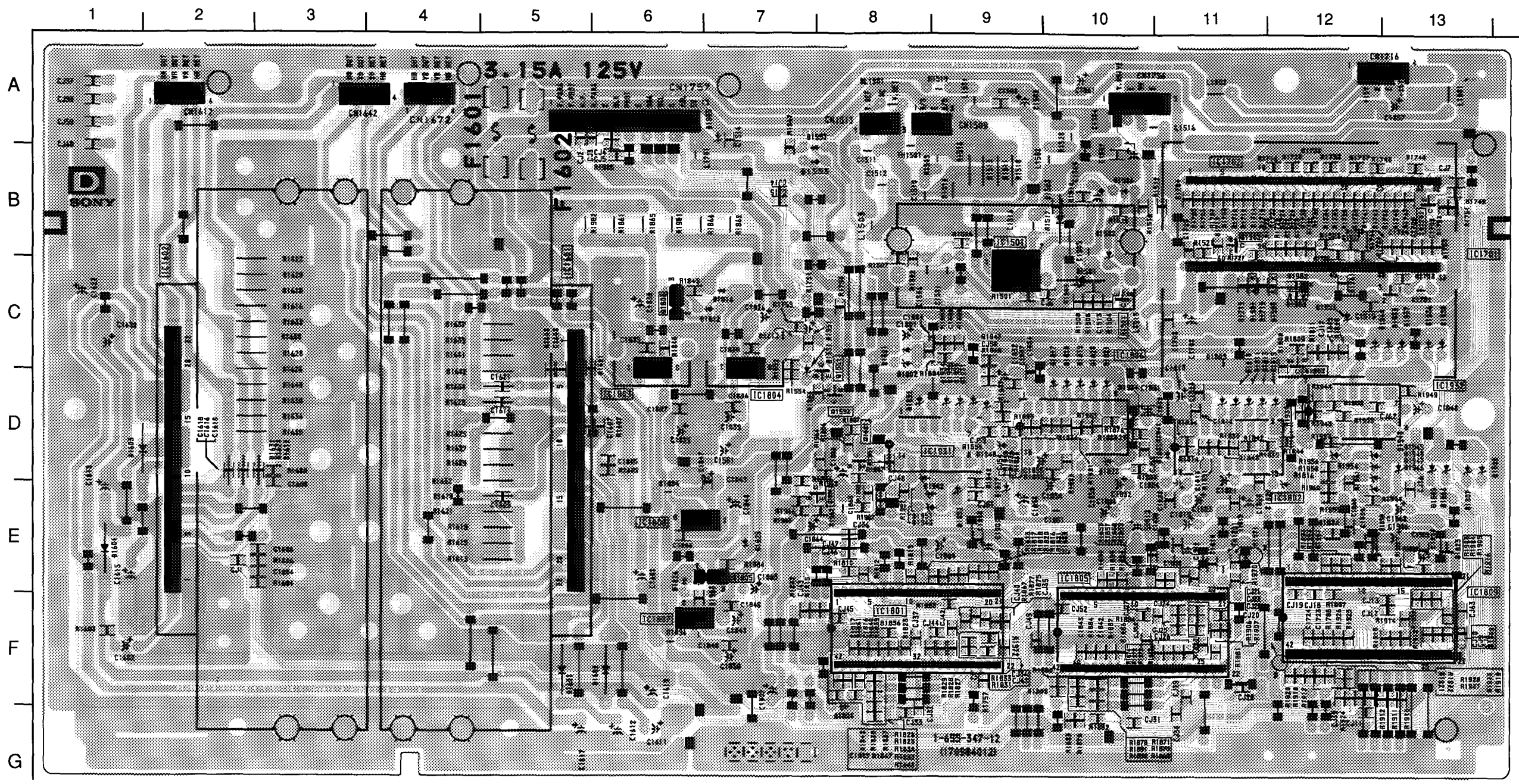

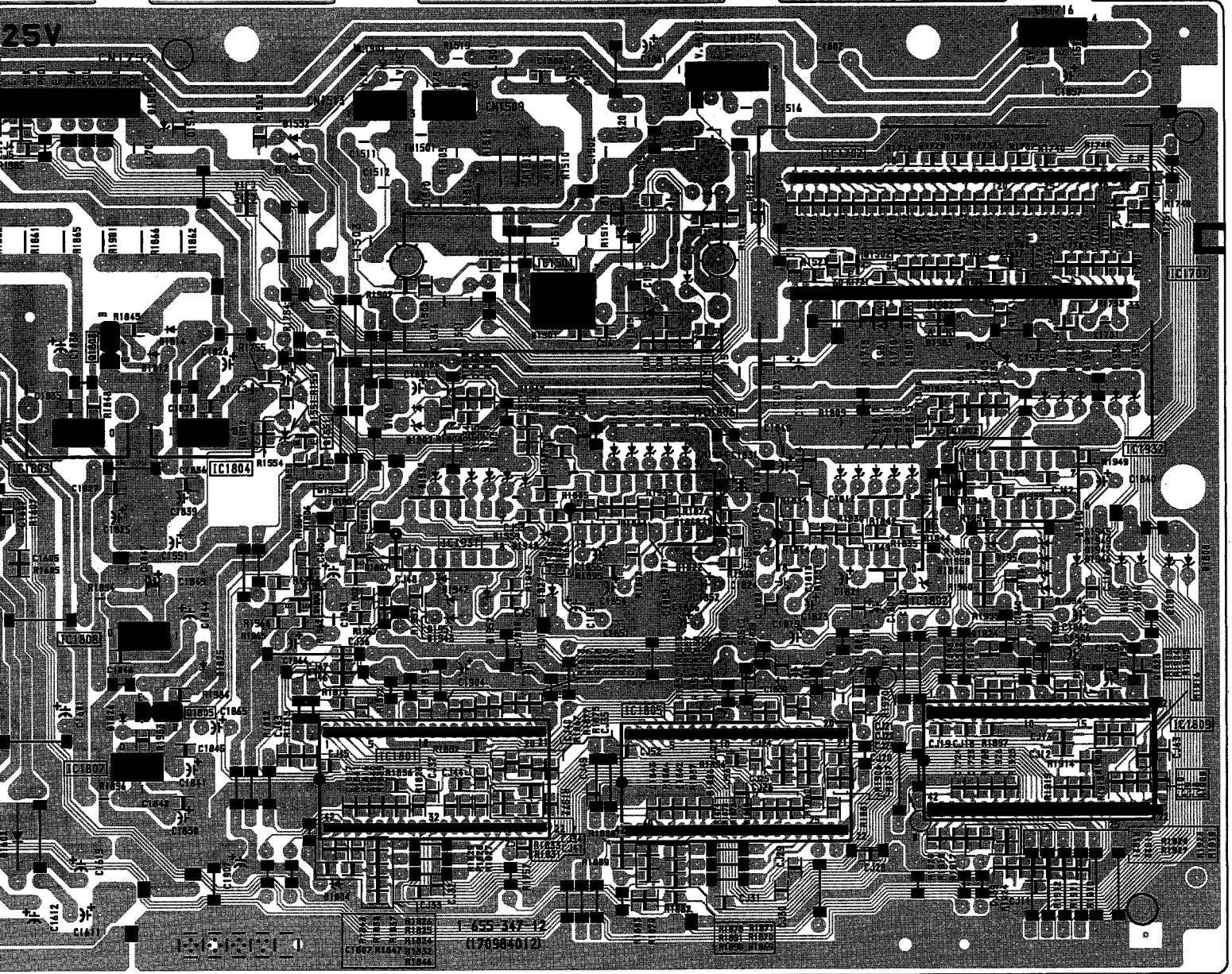

U COM FILTER, AV, SW,
VIDEO IN/OUT, AUDIO IN/OUT

- U BOARD -

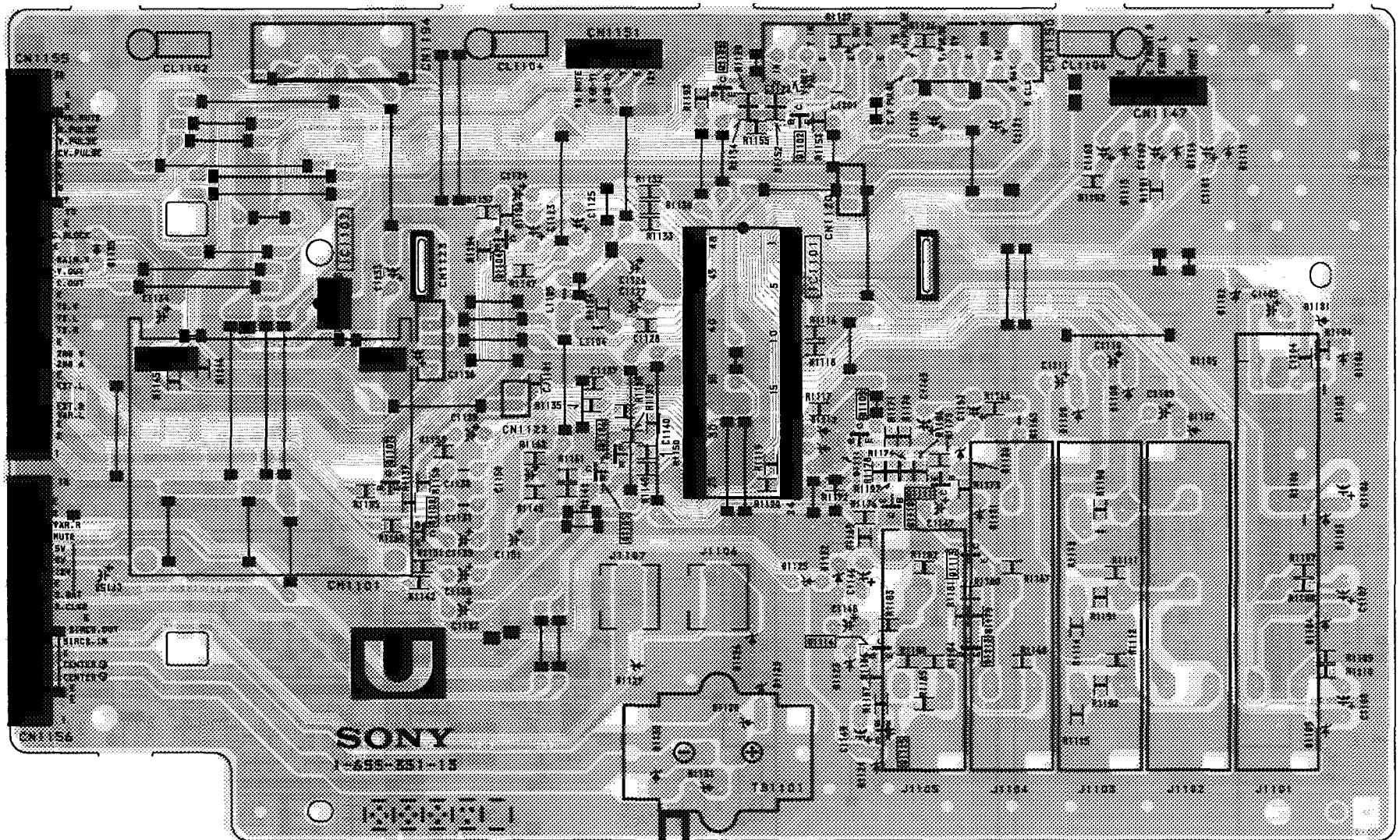

AV, SW,
AUDIO IN/OUT

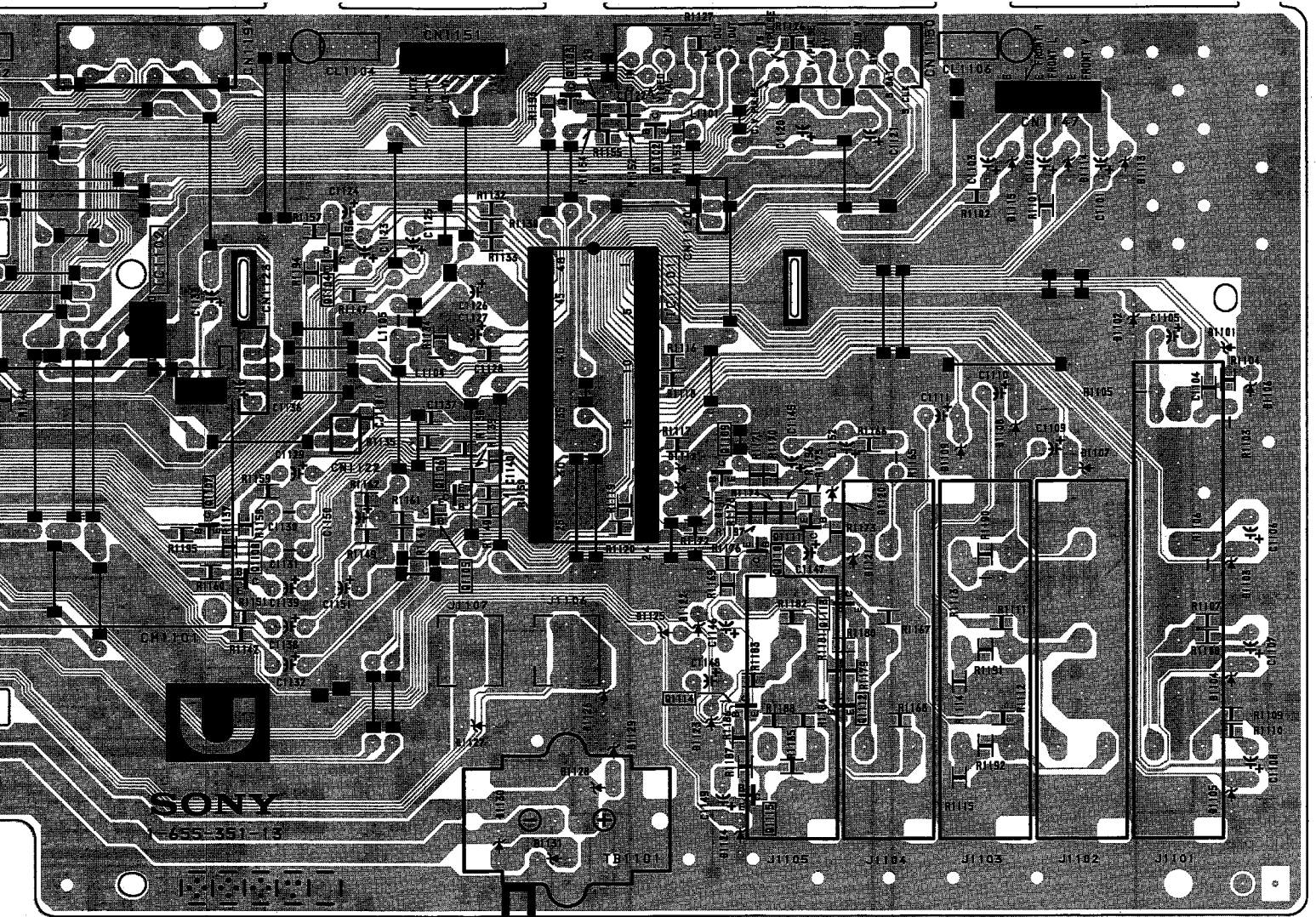

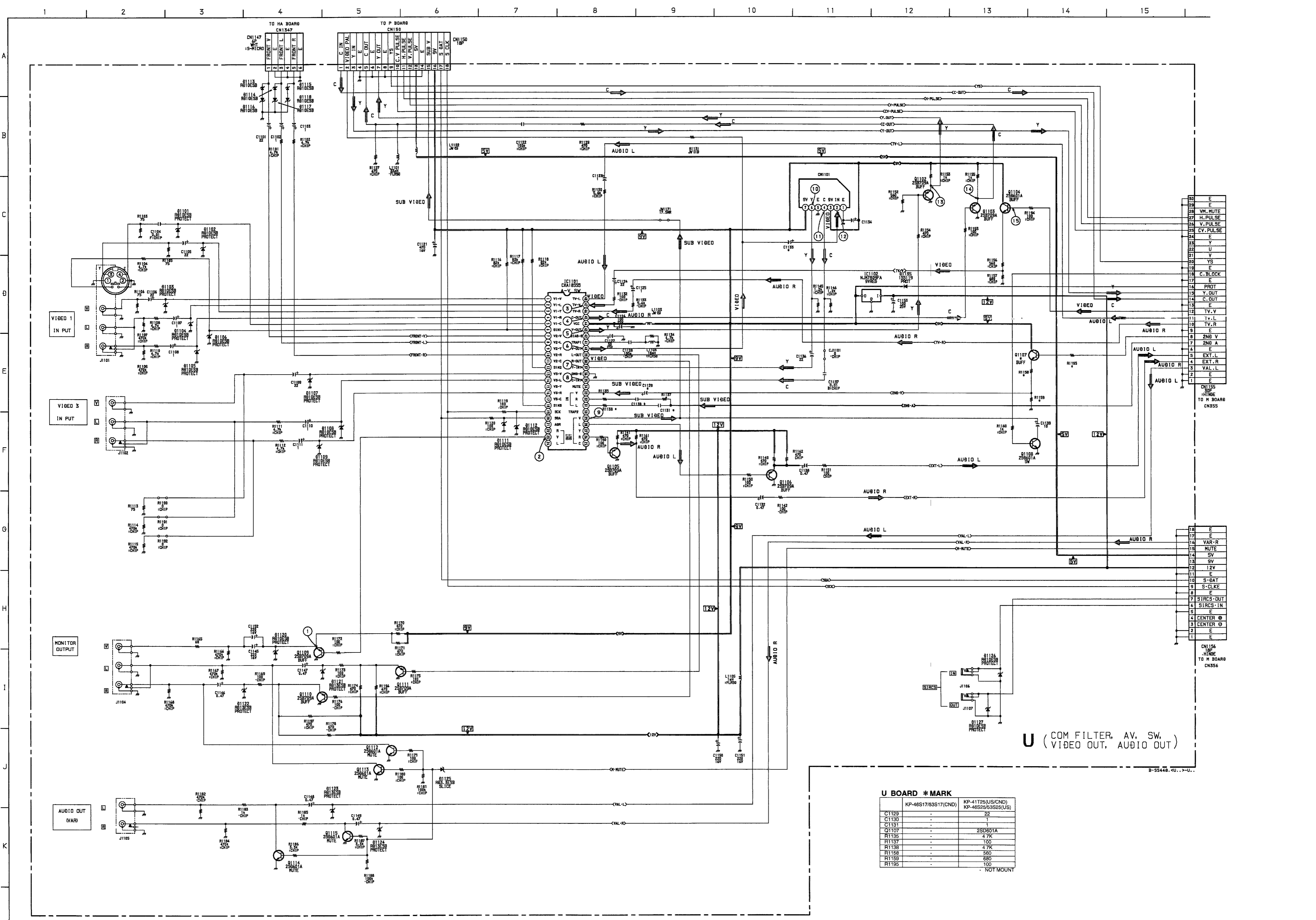

U BOARD * MARK

Component	Value	Value
C1129	-	22
C1130	-	22
C1131	-	1
C1107	-	2SD801A
R1135	-	4.7K
R1137	-	100
R1138	-	4.7K
R1158	-	560
R1159	-	680
R1195	-	100
		NOT MOUNT

U (COM FILTER, AV, SW, VIDEO OUT, AUDIO OUT)

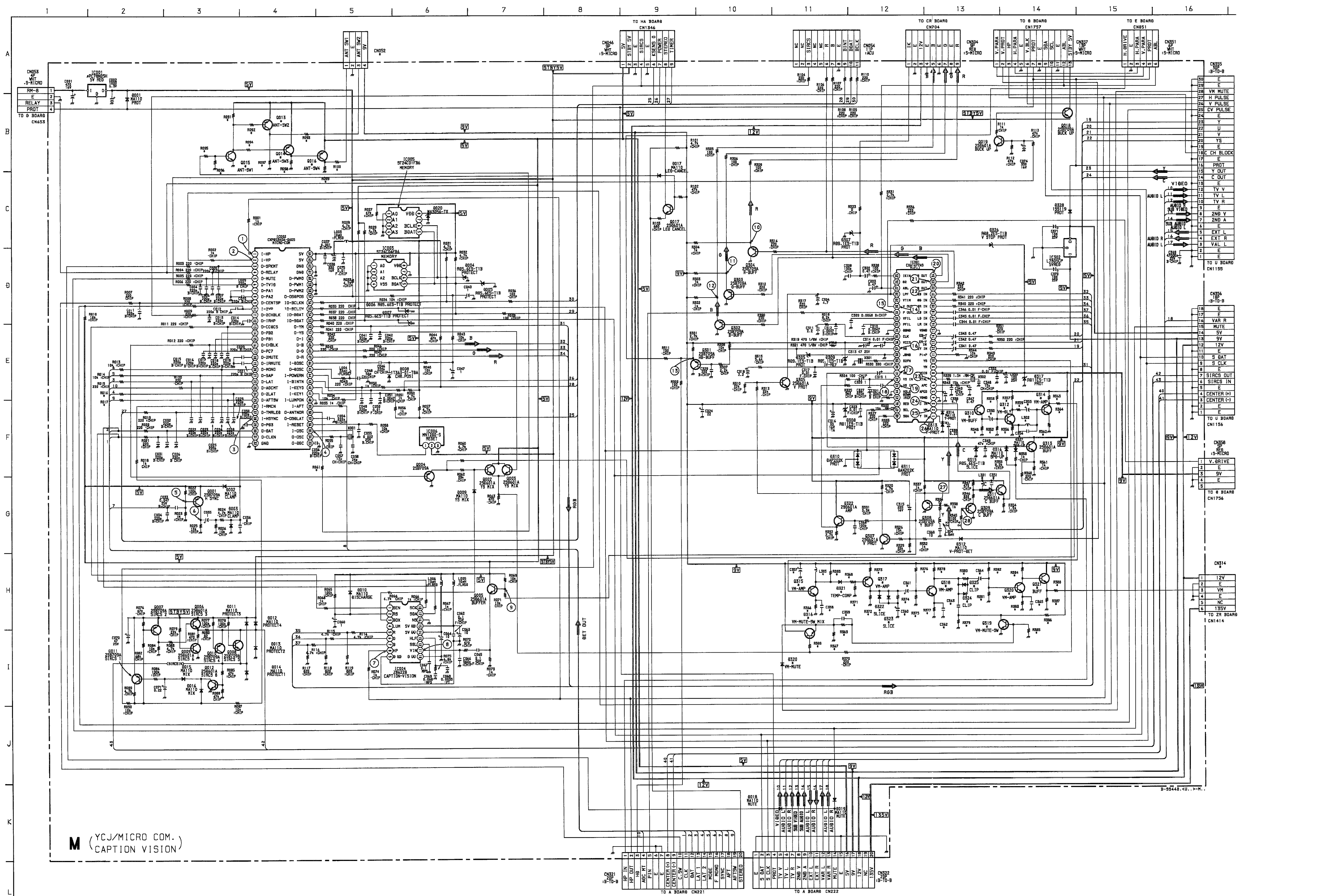

M (YCJ/MICRO COM.)
(CAPTION VISION)

- M BOARD -

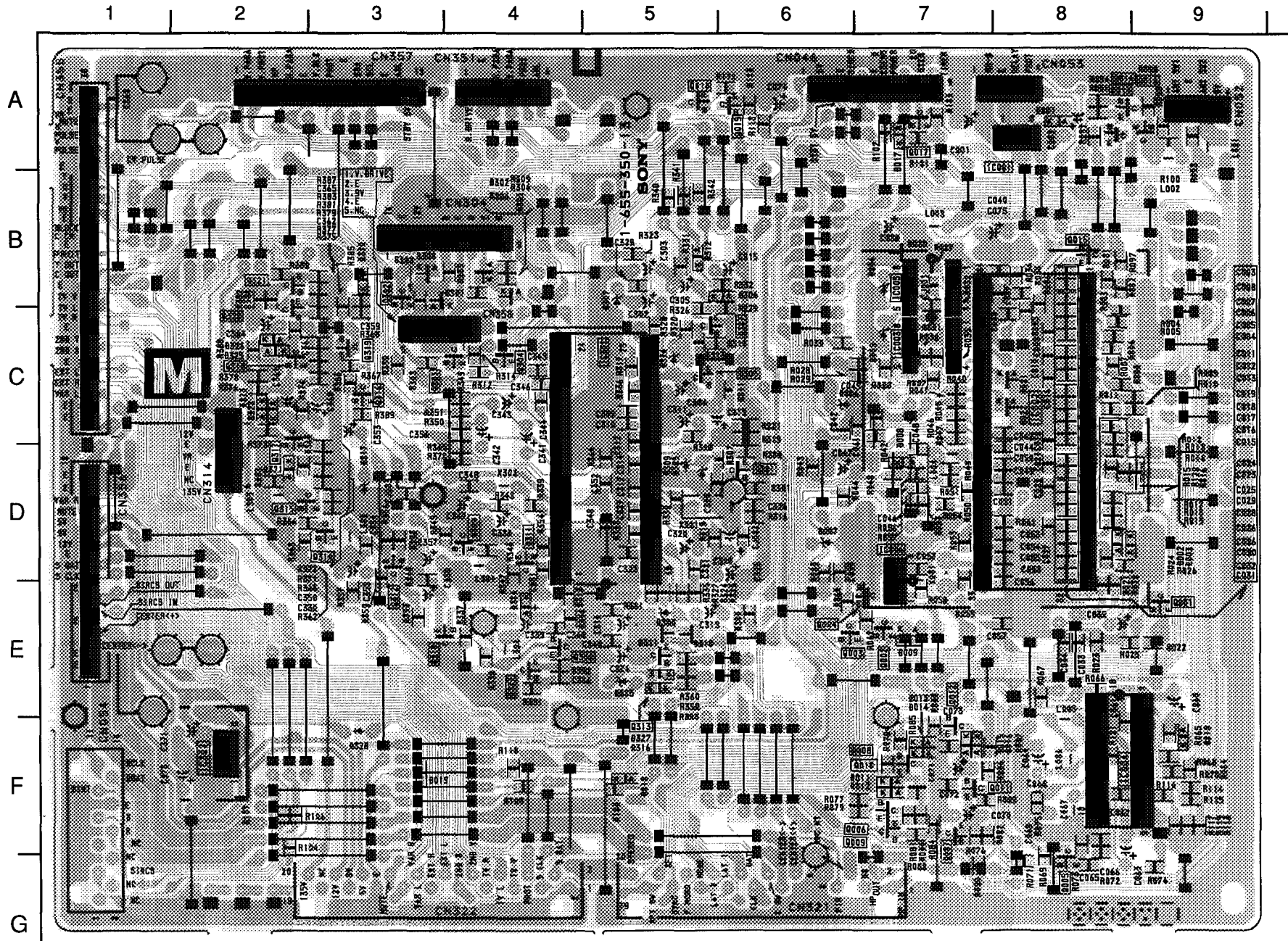

M BOARD * MARK

C350	KP-41T25(US/CND)	KP-46S17/53S17(CND)	KP-46S25/53S25	Q312	2SD601A	-	-	R369	3.3K	-	-
C354	22P	-	-	Q314	2SD601A	-	-	R371	1.0K	-	-
C355	22	-	-	Q315	2SD601A	-	-	R372	1.2K	-	-
C357	47 25V	-	-	Q316	2SD601A	-	-	R373	270	-	-
C358	15P	-	-	Q317	2SB709A	-	-	R374	33K	-	-
C359	220P	-	-	Q318	2SD601A	-	-	R375	12K	-	-
C360	10	-	-	Q319	2SD601A	-	-	R376	68K	-	-
C361	10	-	-	Q320	2SD601A	-	-	R377	560	-	-
C362	22P	-	-	Q321	2SD601A	-	-	R378	2.7K	-	-
C363	0.001	-	-	R348	1.0K	-	-	R379	27K	-	-
C364	10	-	-	R352	2.2K	-	-	R380	100K	-	-
C365	22P	-	-	R353	6.8K	-	-	R381	8.2K	-	-
CN314	6P	-	-	R356	180	-	-	R382	33K	-	-
D320	MA110	-	-	R357	180	-	-	R383	560	-	-
D321	MA110	-	-	R359	330	-	-	R384	1.5K	-	-
D322	MA110	-	-	R362	270	-	-	R385	33K	-	-
D323	MA110	-	-	R363	1.0K	-	-	R386	1.0M	-	-
D324	MA110	-	-	R364	100	-	-	R387	1.0K	-	-
D325	MA110	-	-	R366	1.5K	-	-	R388	100	-	-
IC002	CXP85332A-046S	CXP85340A-06S	CXP85332A-046S	R367	2.2K	-	-	R389	220	-	-
Q310	2SD601A	-	-	R368	100	-	-	R393	1K	-	-

- NOT MOUNT

5 | 6 | 7 | 8 | 9

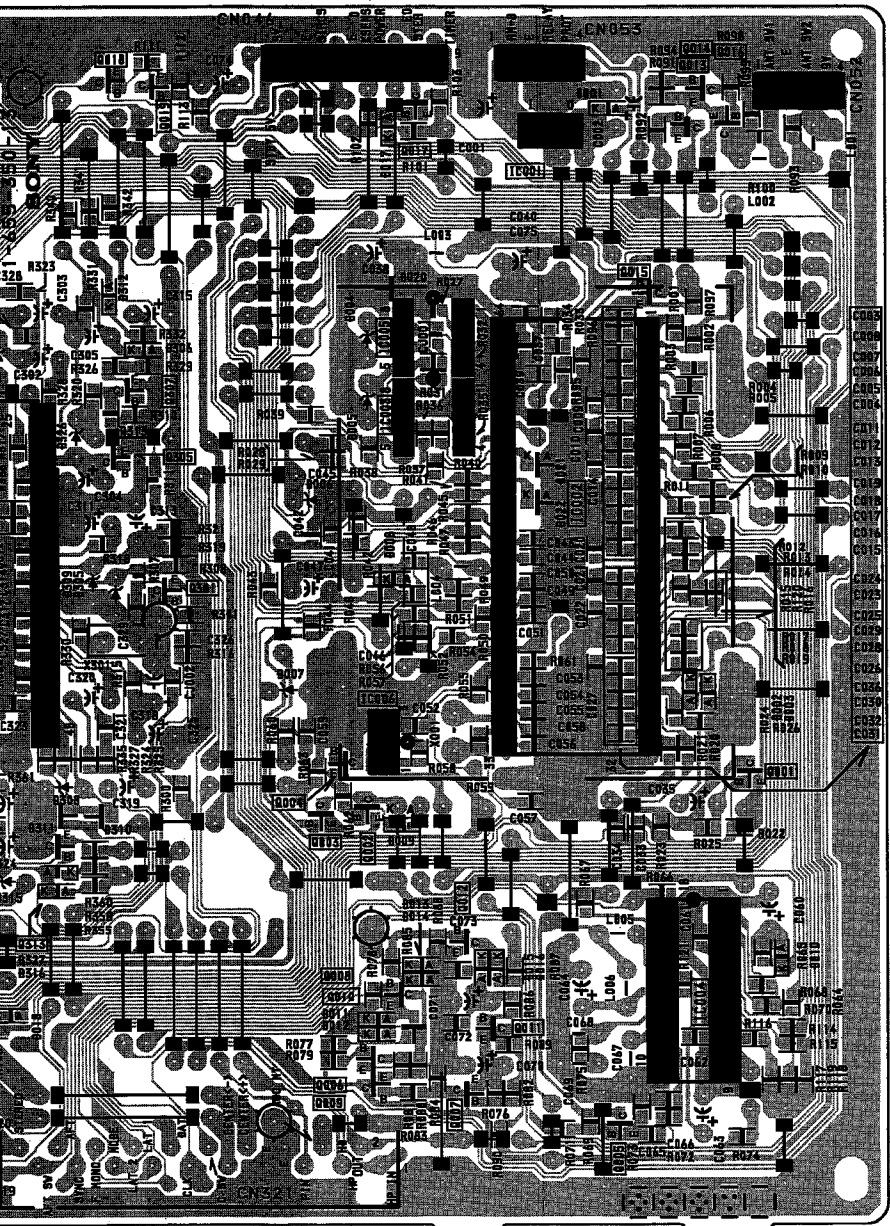

CND)	KP-46S17/53S17(CND)	KP-46S25/53S25		KP-41T25(US/CND)	KP-46S17/53S17(CND)	KP-46S25/53S25
			R369	3.3K		
			R371	1.0K		
			R372	1.2K		
			R373	270		
			R374	33K		
			R375	12K		
			R376	68K		
			R377	560		
			R378	2.7K		
			R379	27K		
			R380	100K		
			R381	8.2K		
			R382	33K		
			R383	560		
			R384	1.5K		
			R385	33K		
			R386	1.0M		
			R387	1.0K		
			R388	100		
			R389	220		
			R393	1K		

-- NOT MOUNT

P [PICTURE IN PICTURE]

- P BOARD -

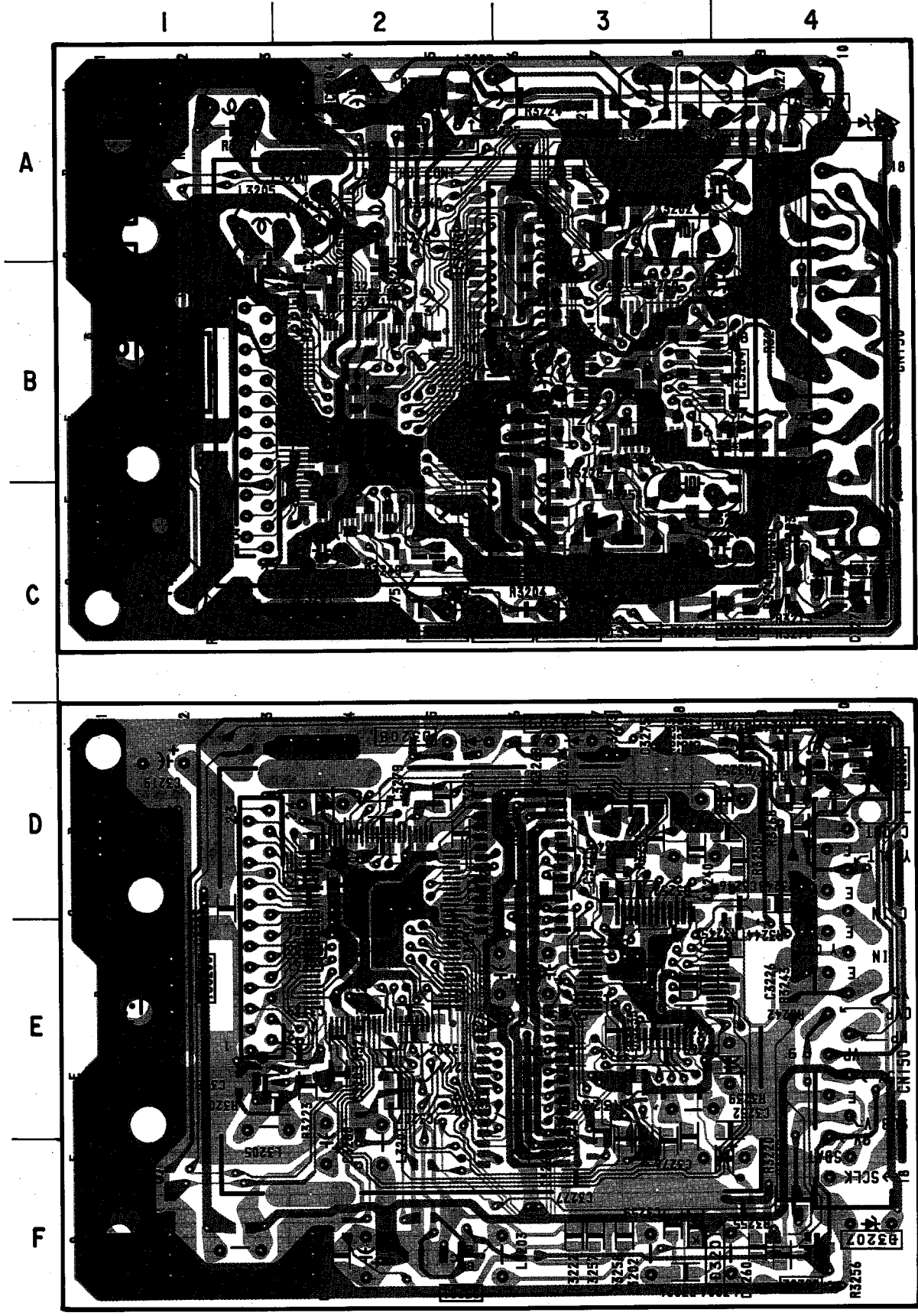

les seeing.

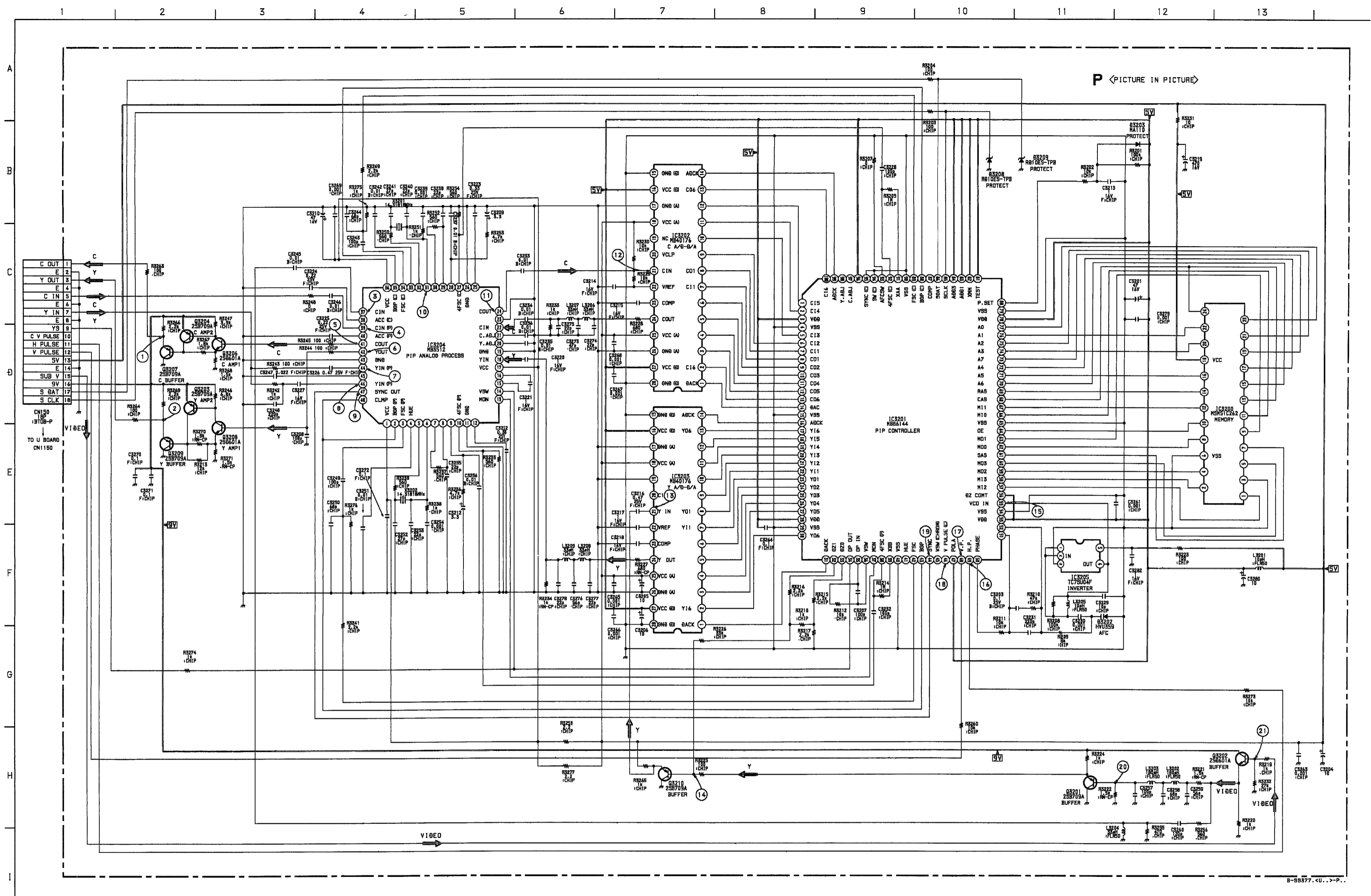

8-98577-00...-P-

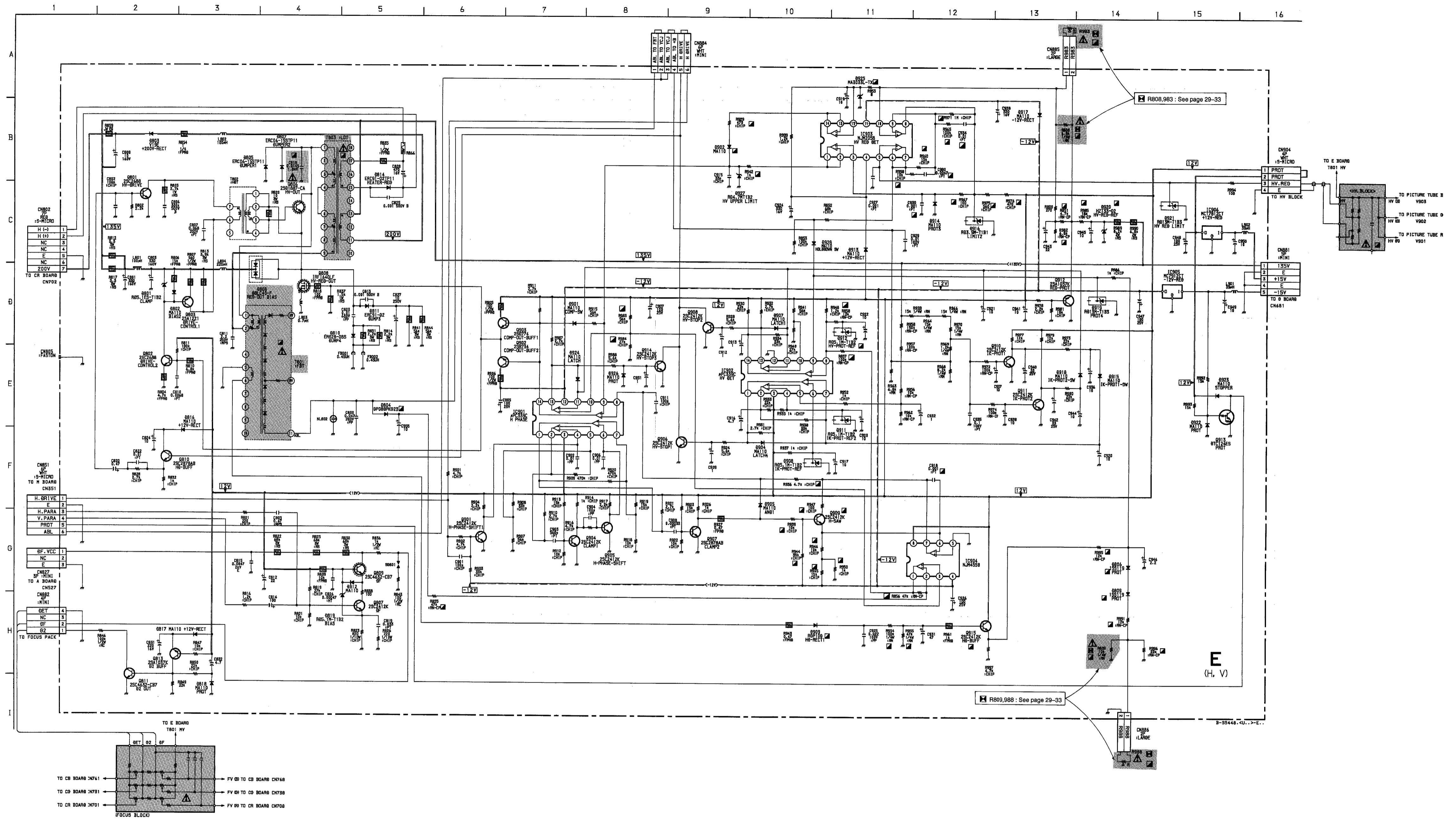

- E BOARD -

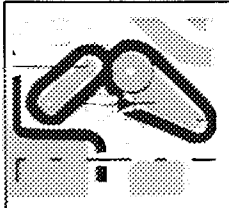
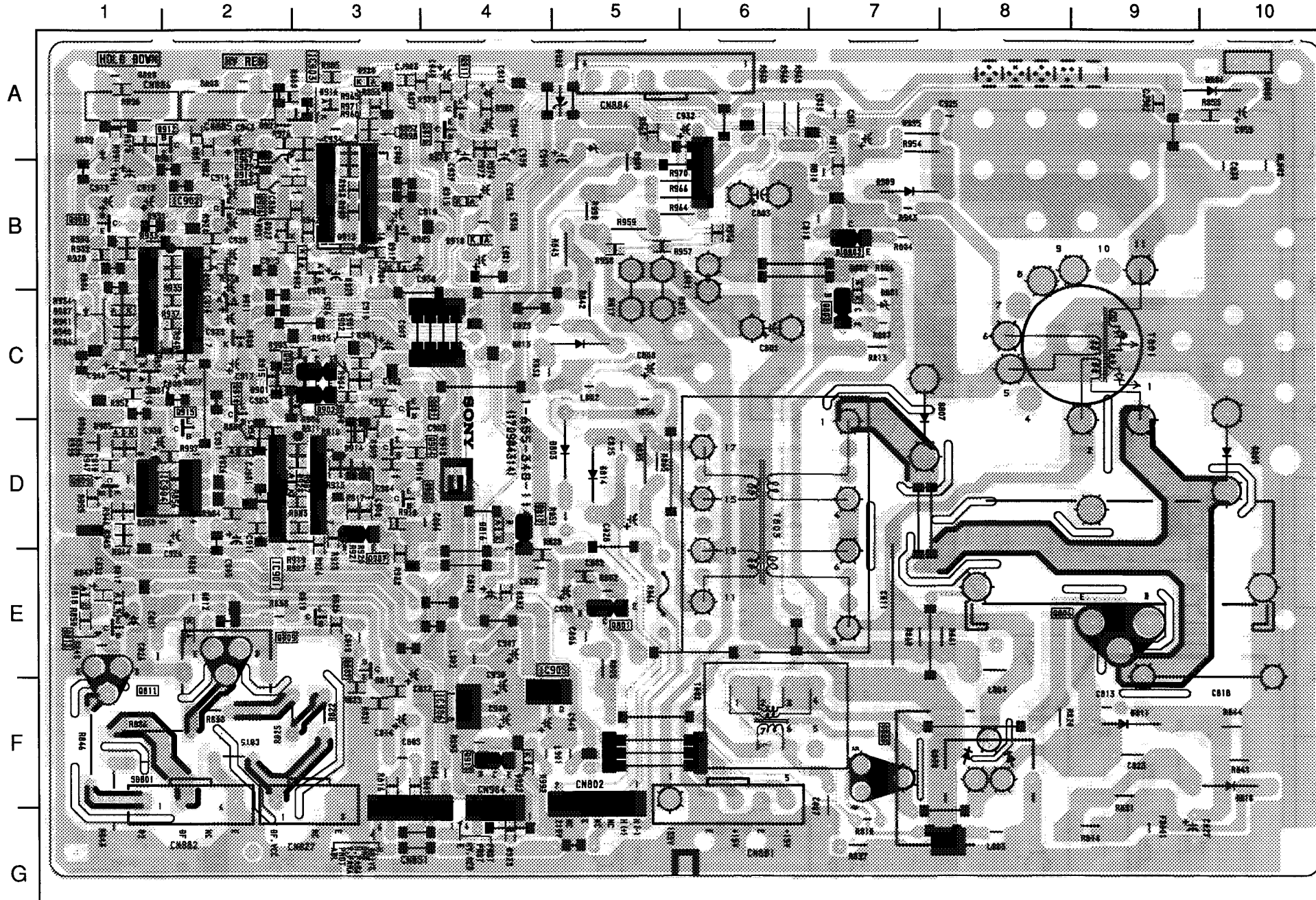

NOTE:
 The circuit indicated as left contains high voltage of over 600 Vp-p. Care must be paid to prevent an electric shock in inspection or repairing.

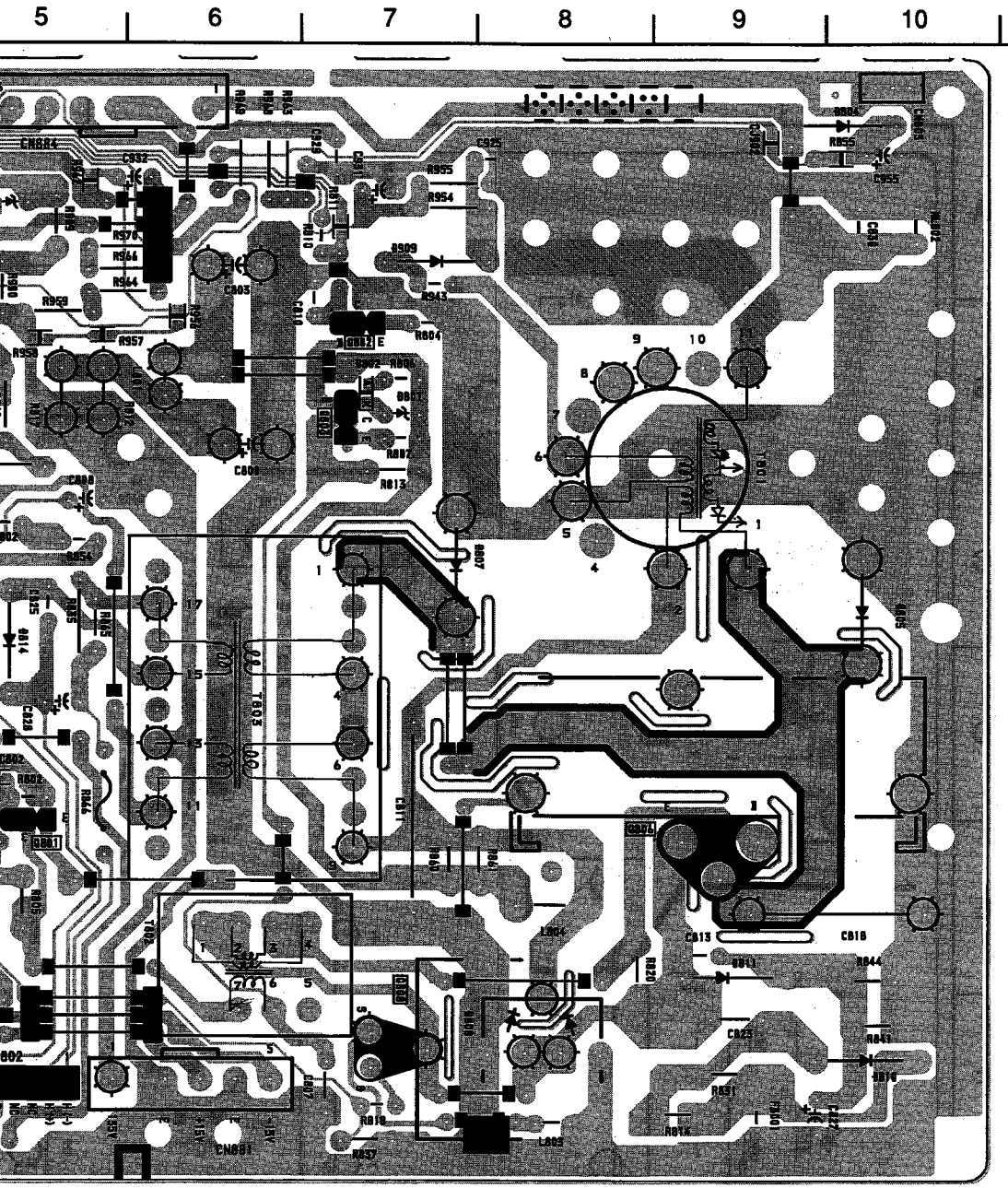

age of over
ic shock in

G [POWER SUPPLY]

- G BOARD -

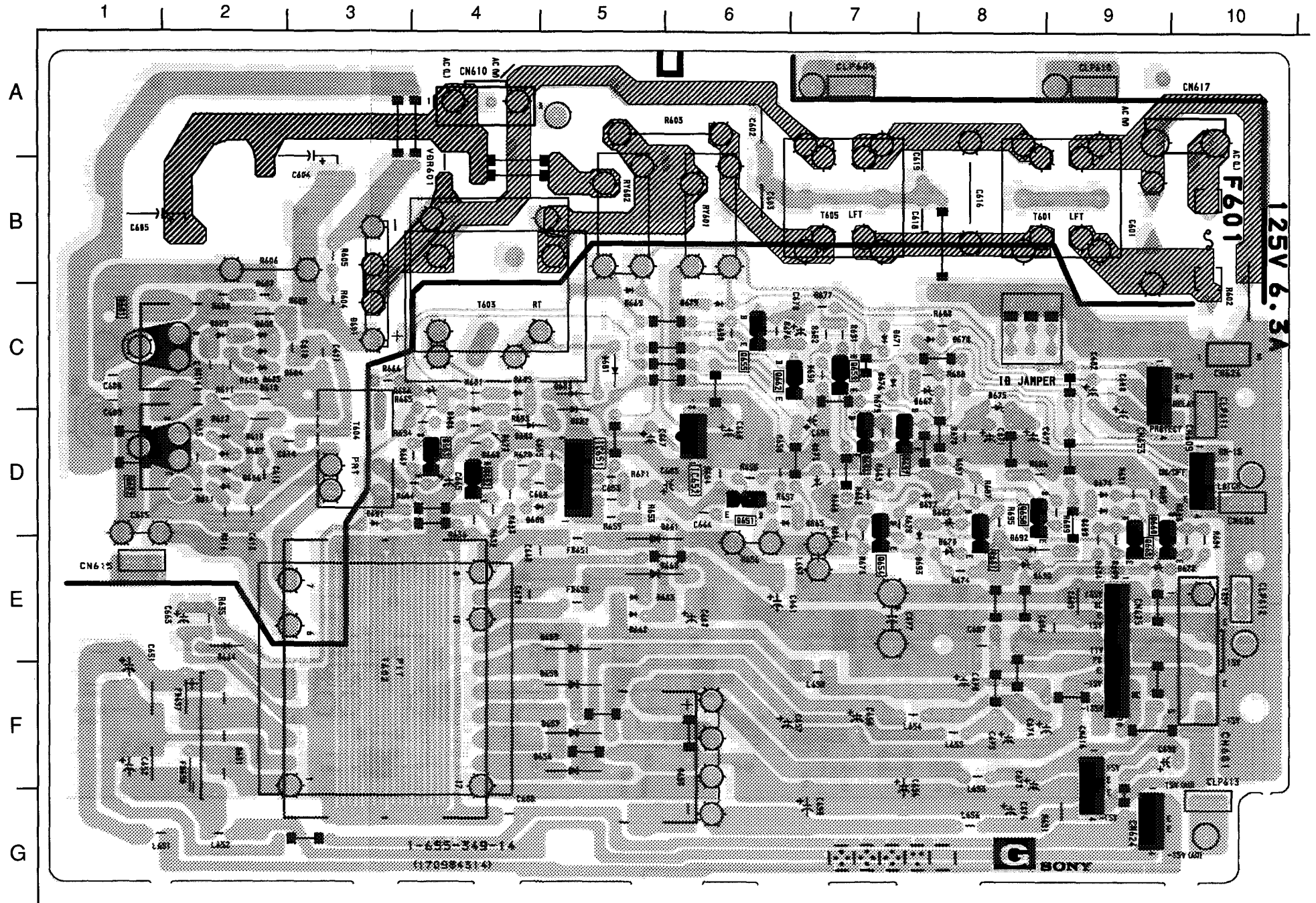

3

4

5

6

7

8

9

10

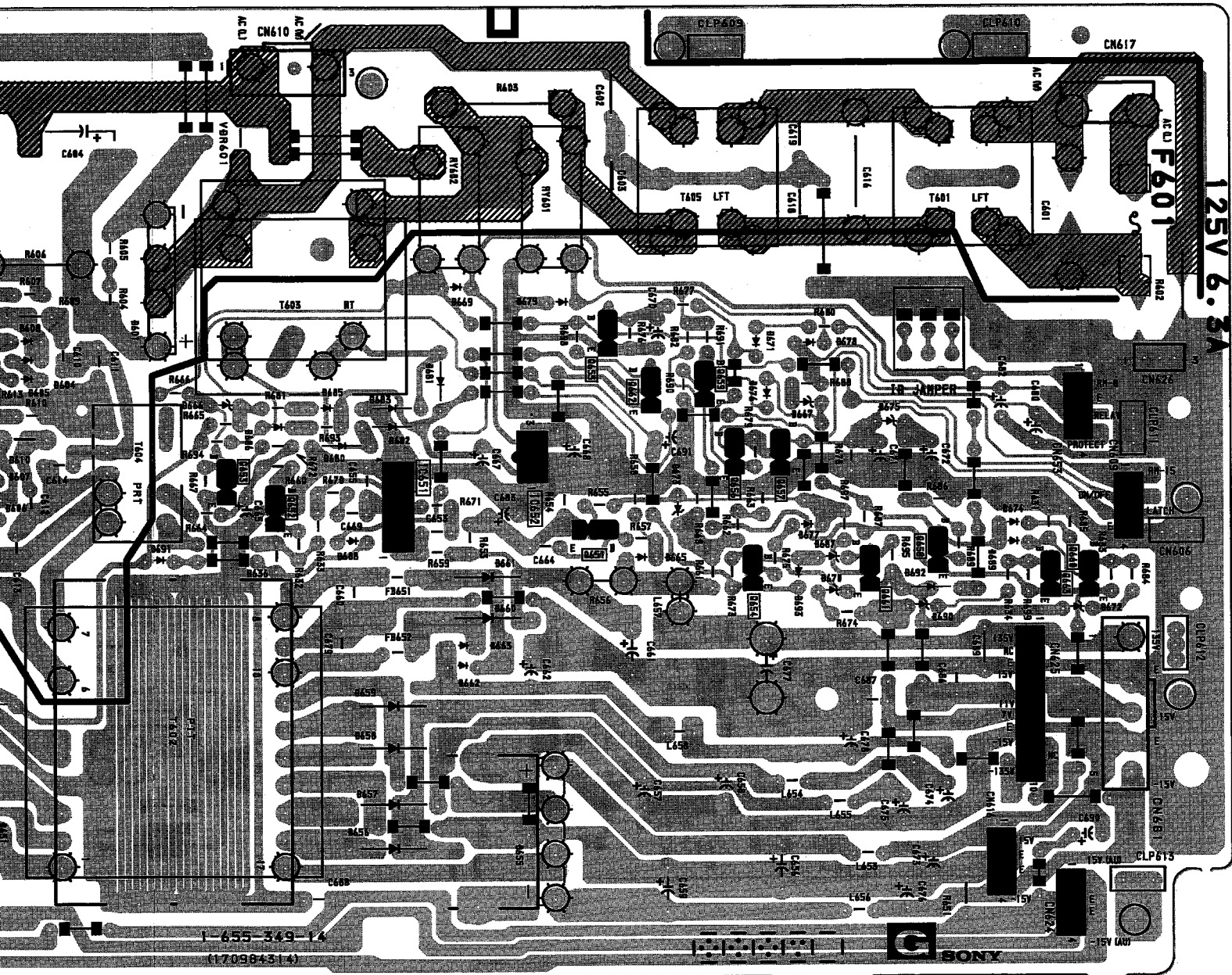

125V 6.3A

1-655-349-14
(1709843-14)

SONY

G (POWER SUPPLY)

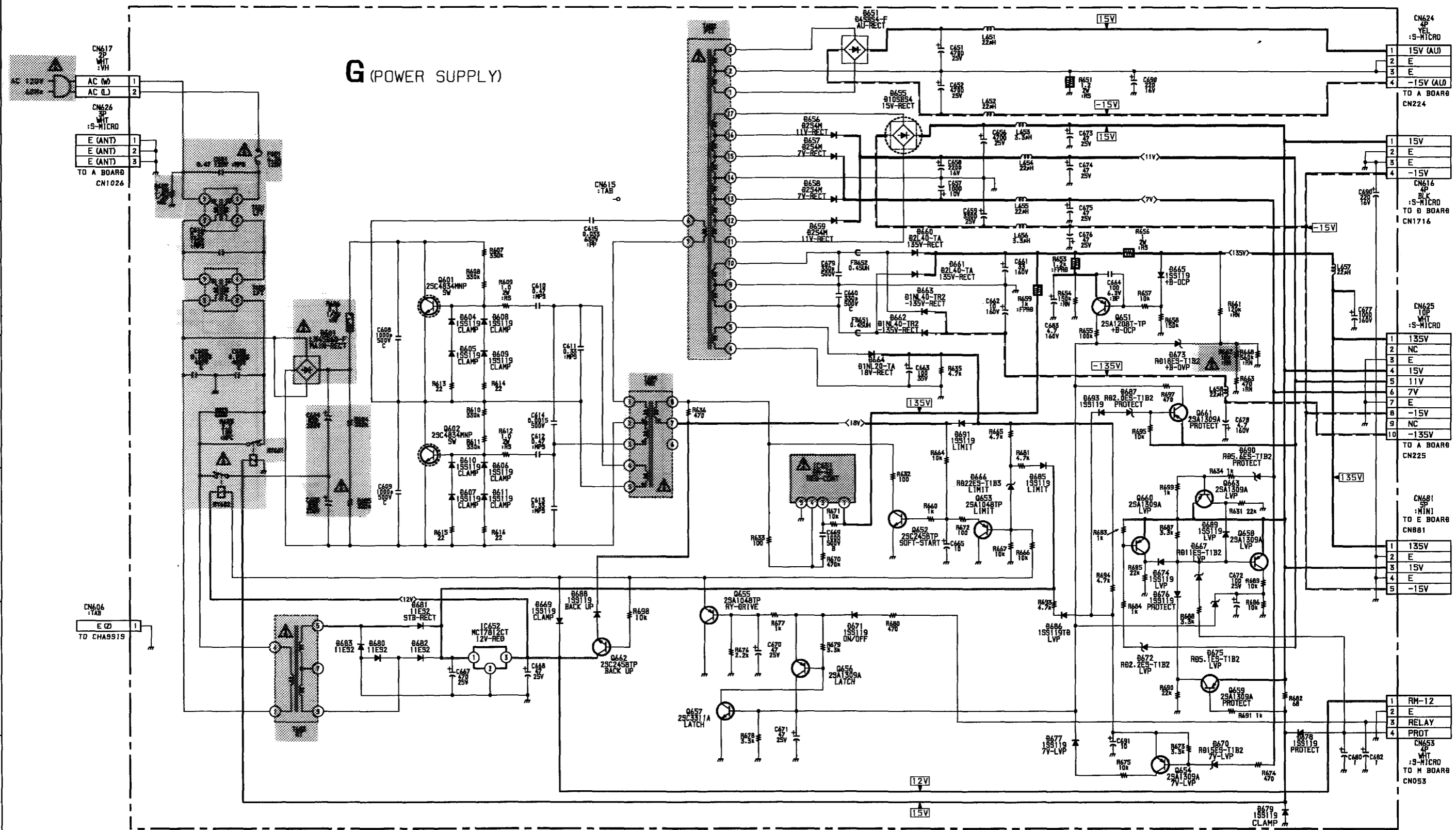

- 1 15V (AU)
 - 2 E
 - 3 E
 - 4 -15V (AU)
- TO A BOARD CN224
- 1 15V
 - 2 E
 - 3 E
 - 4 -15V
- TO B BOARD CN1716
- 1 135V
 - 2 NC
 - 3 E
 - 4 15V
 - 5 11V
 - 6 7V
 - 7 E
 - 8 -15V
 - 9 NC
 - 10 -135V
- TO A BOARD CN225
- 1 135V
 - 2 E
 - 3 15V
 - 4 E
 - 5 -15V
- 1 RM-12
 - 2 E
 - 3 RELAY
 - 4 PROT
- TO H BOARD CN053

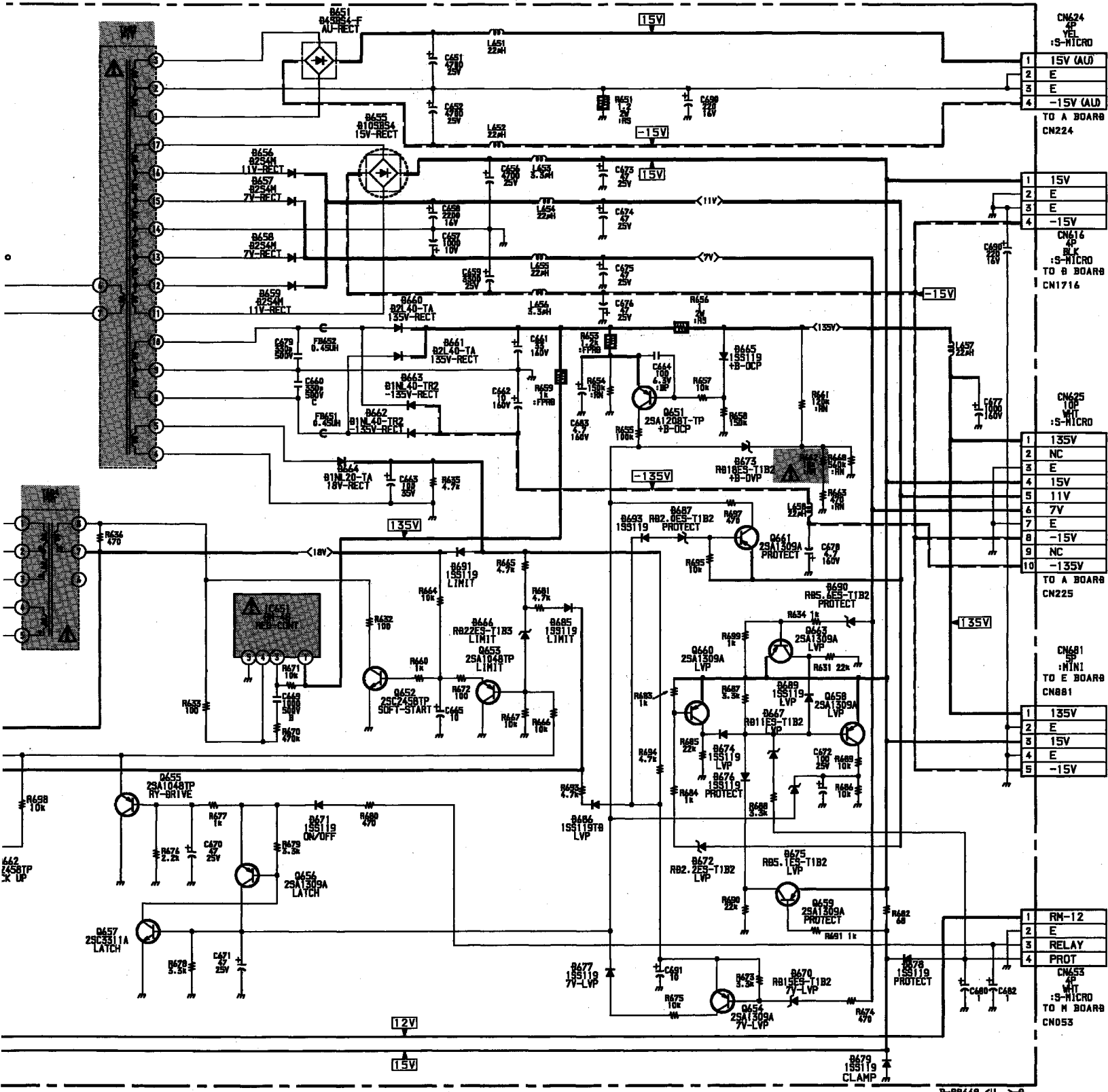

1	15V (AU)
2	E
3	E
4	-15V (AU)

TO A BOARD
CN224

1	15V
2	E
3	E
4	-15V

CN416
BLK
:S-MICRO
TO B BOARD
CN1716

1	135V
2	NC
3	E
4	15V
5	11V
6	7V
7	E
8	-15V
9	NC
10	-135V

TO A BOARD
CN225

1	135V
2	E
3	15V
4	E
5	-15V

TO E BOARD
CN881

1	RM-12
2	E
3	RELAY
4	PROT

CN453
WHT
:S-MICRO
TO H BOARD
CN053

B-98448 <U> - 8..

Schematic diagrams

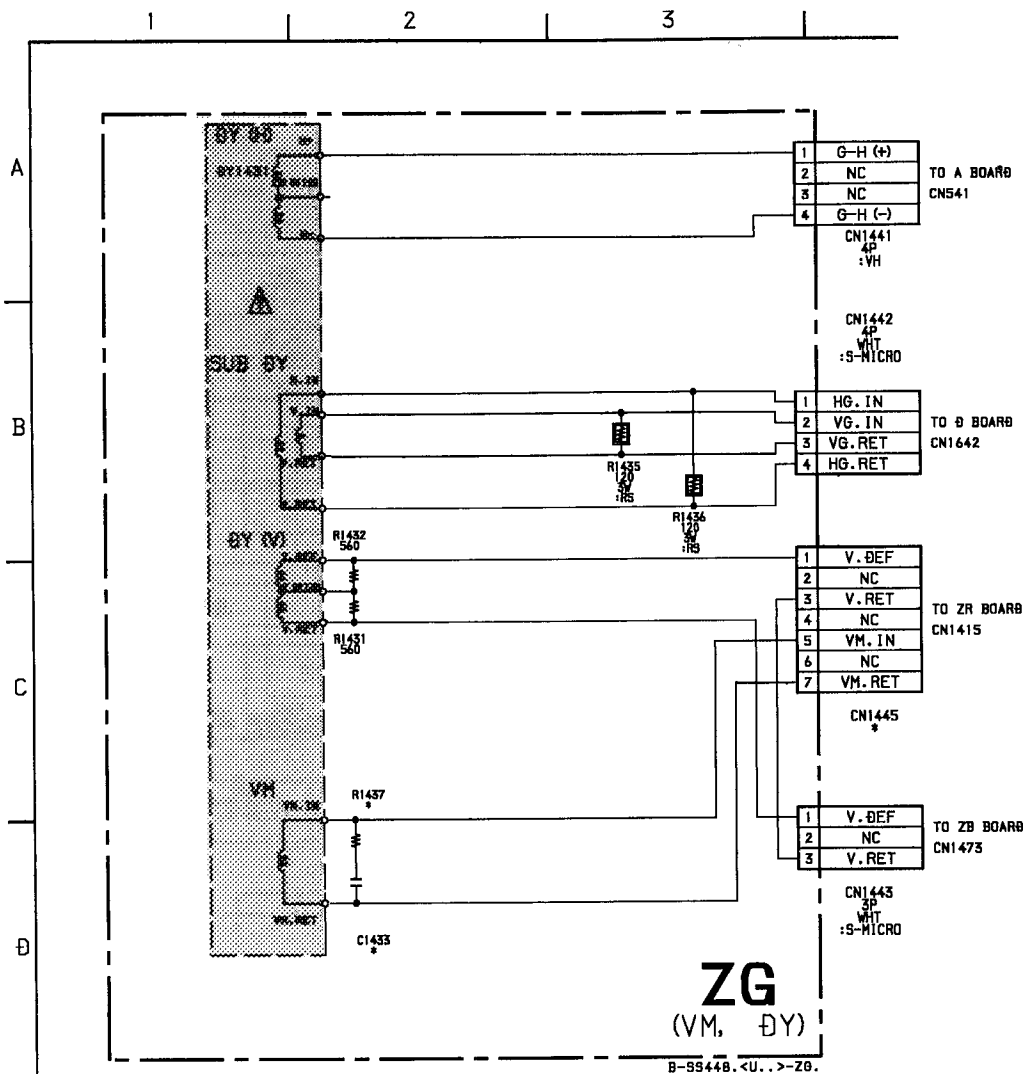

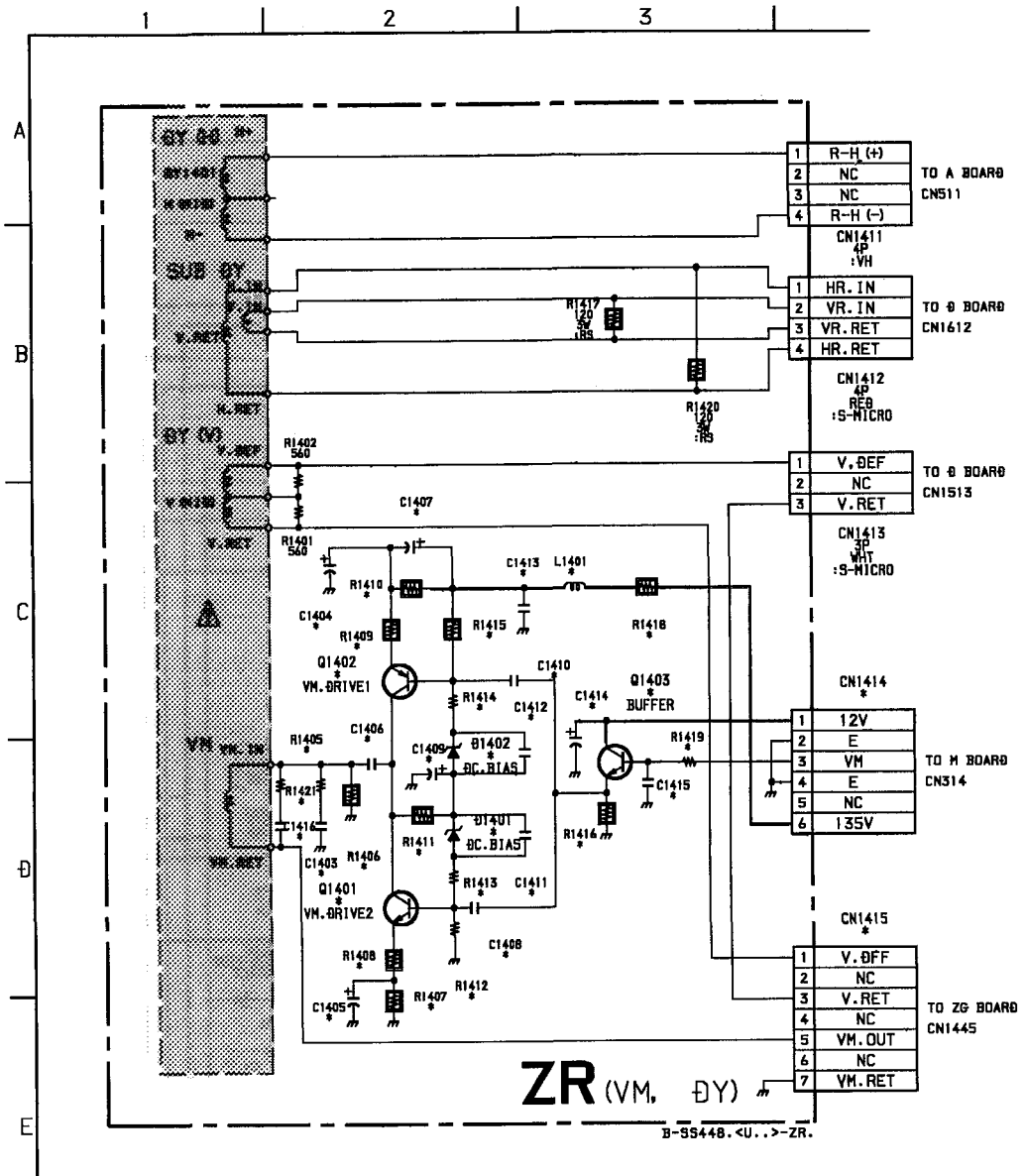

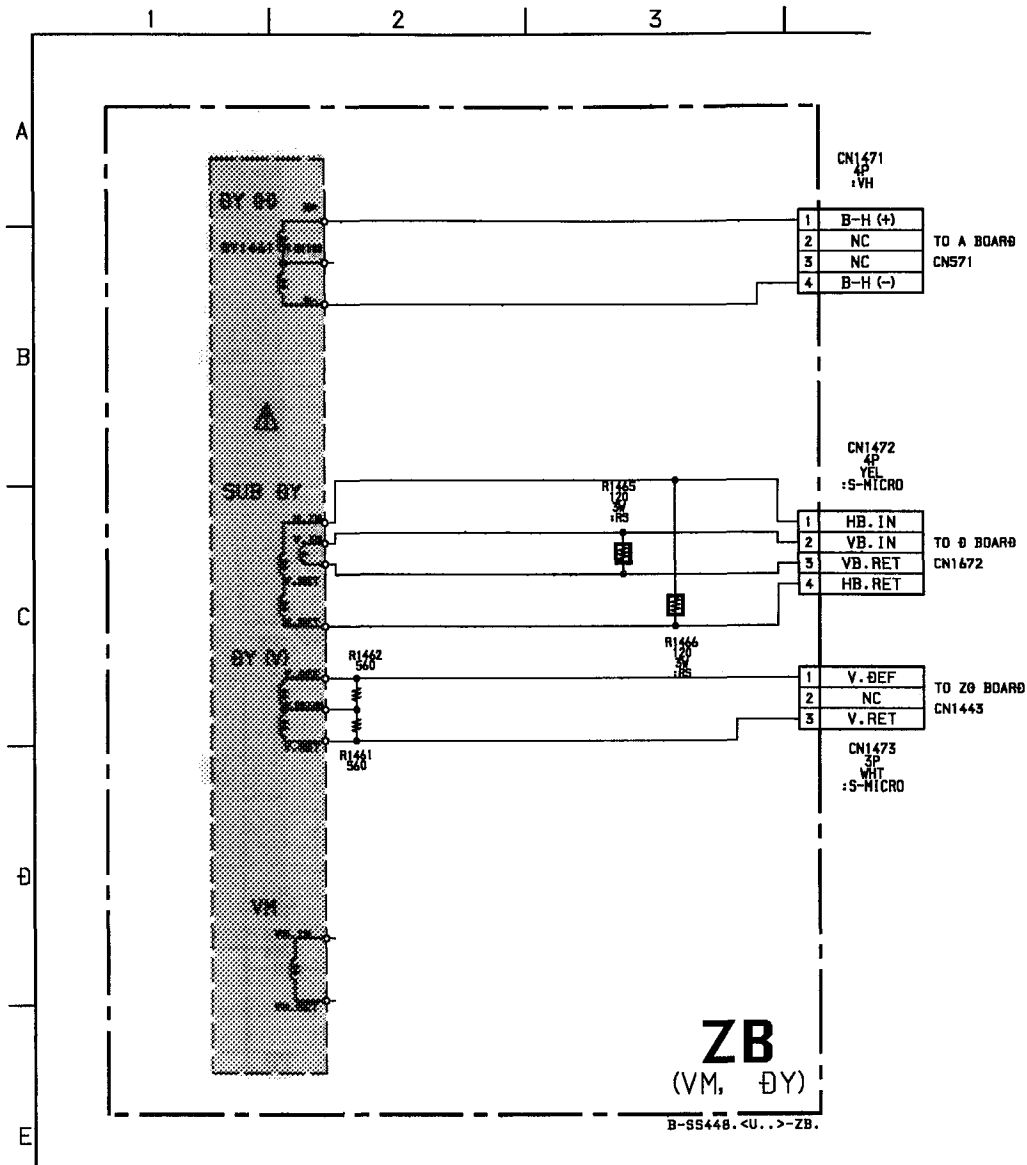

- ZR BOARD -

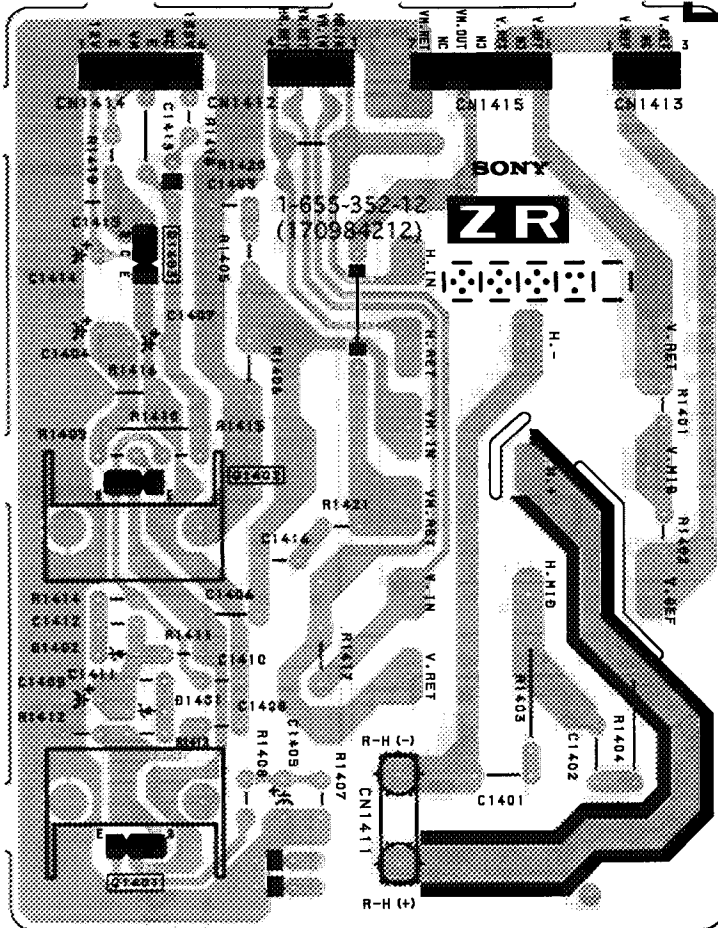

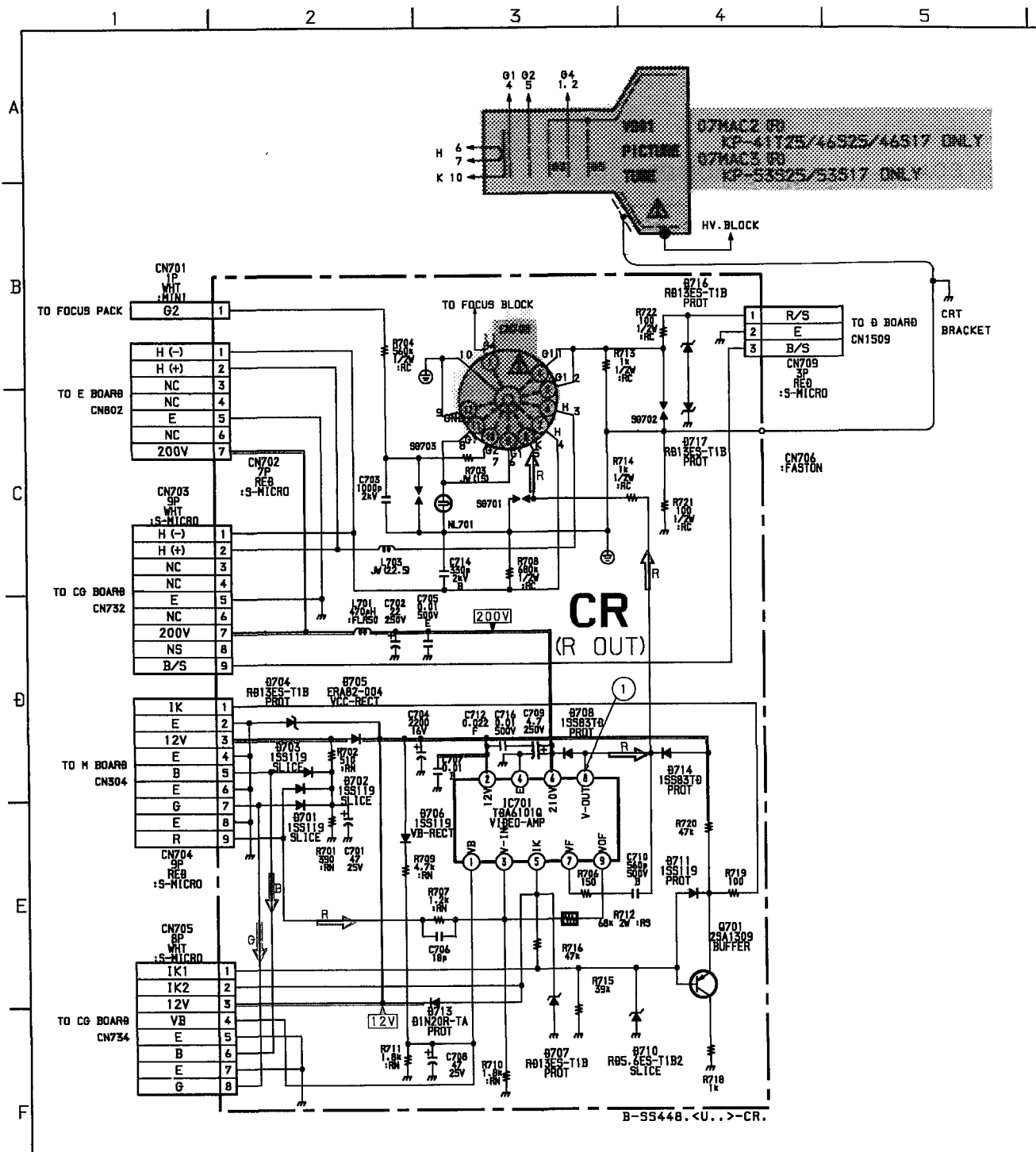

Schematic diagrams

CR CG CB boards →

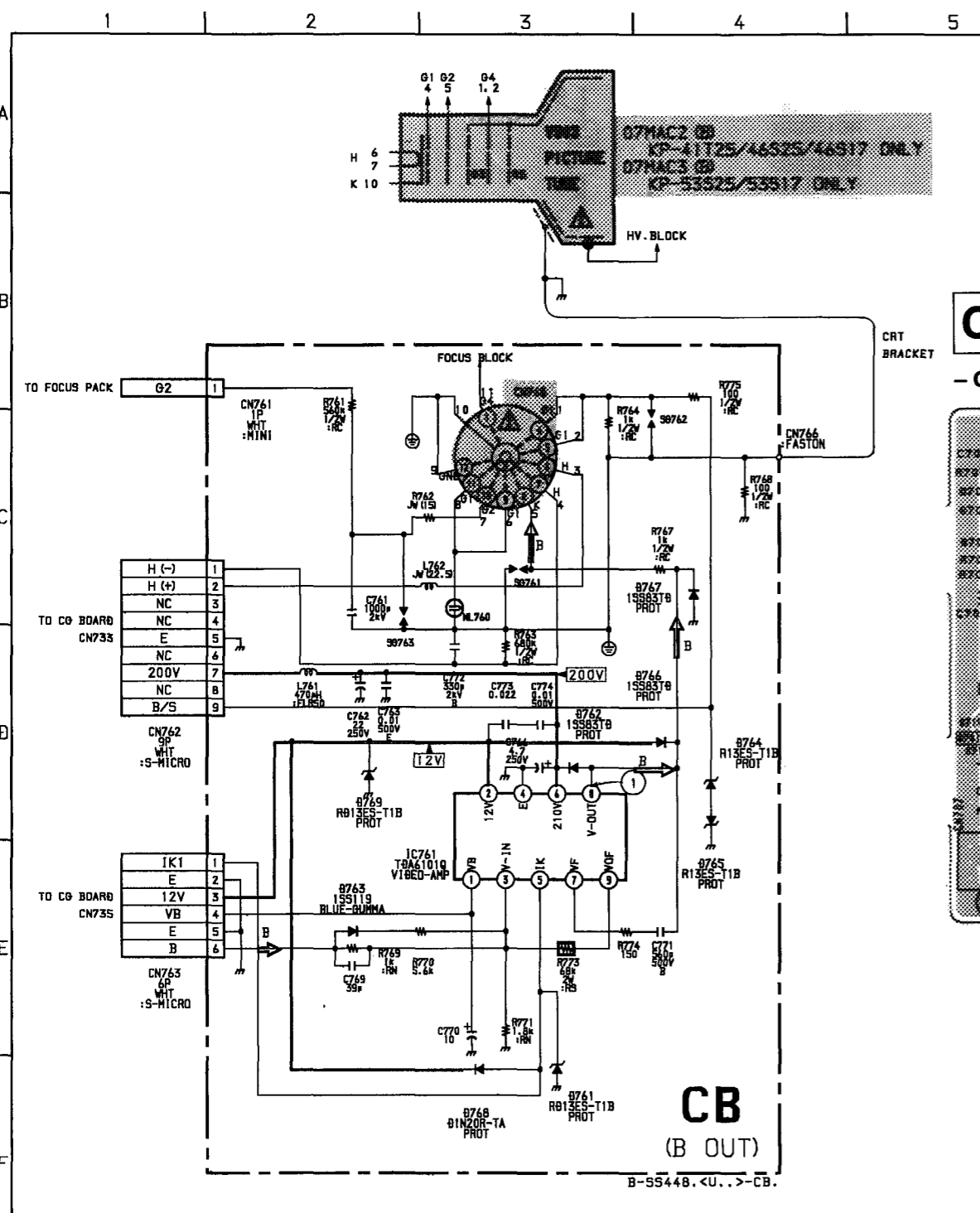

CR [R OUT]
- CR BOARD -

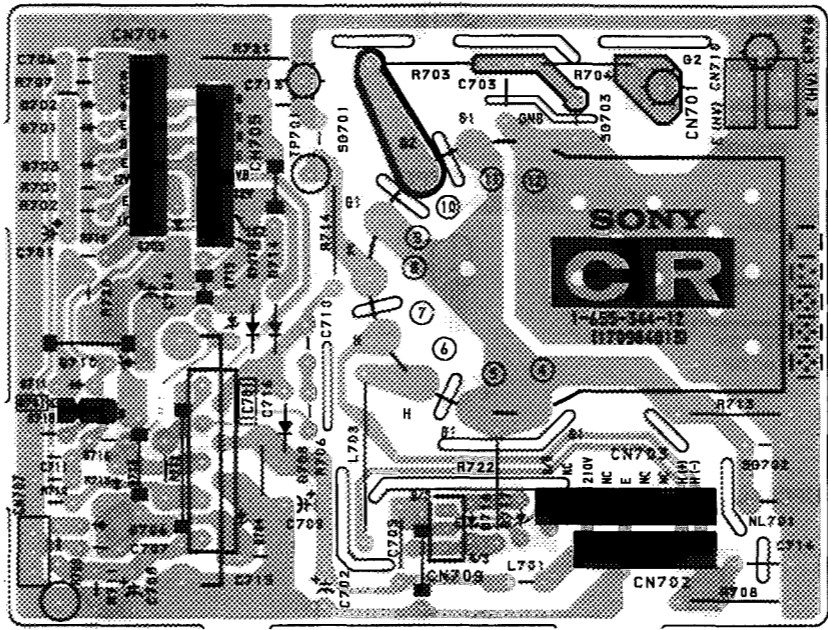

CG [G OUT]
- CG BOARD -

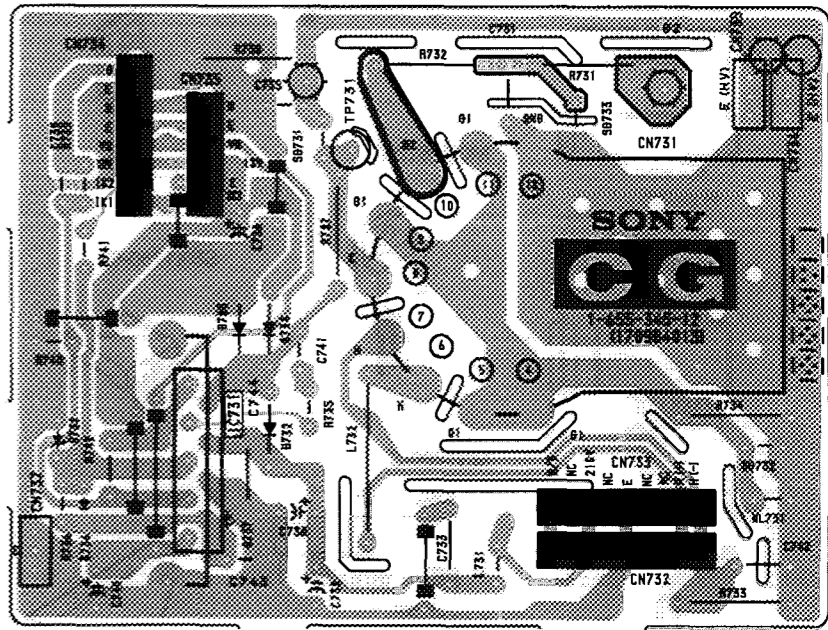

CB [B OUT]
- CB BOARD -

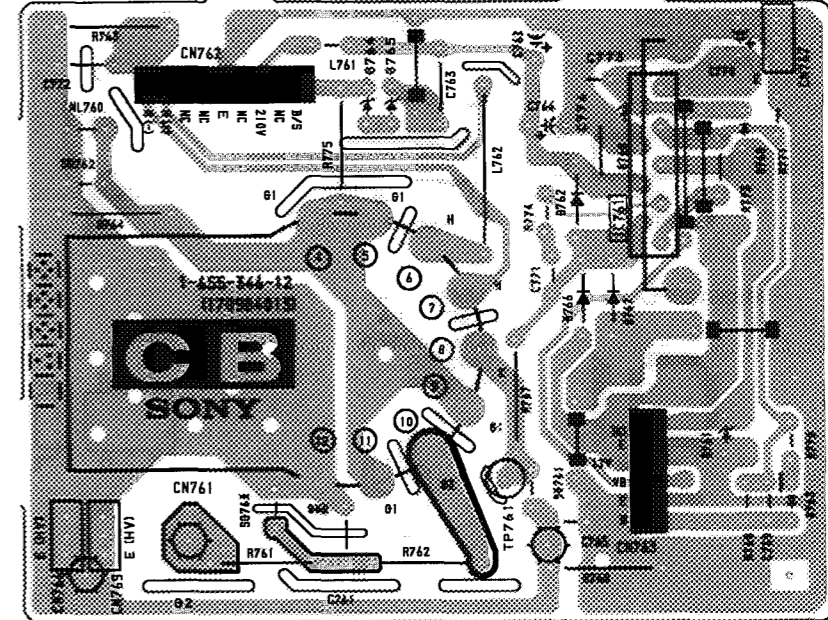

[R OUT]
- BOARD -

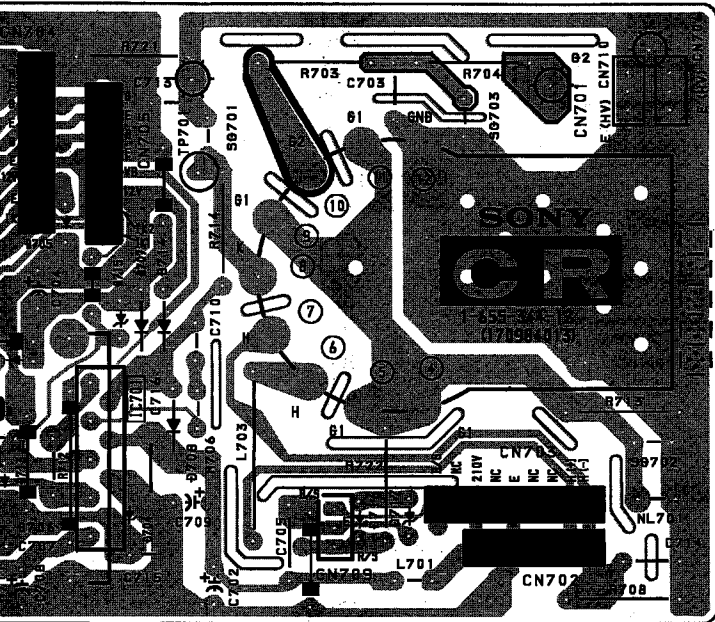

CG [G OUT]
- CG BOARD -

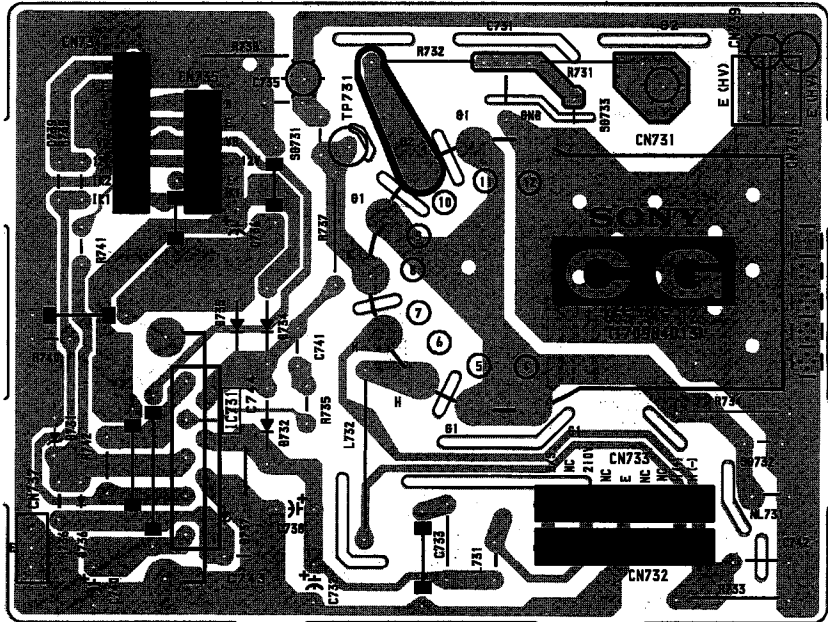

CB [B OUT]
- CB BOARD -

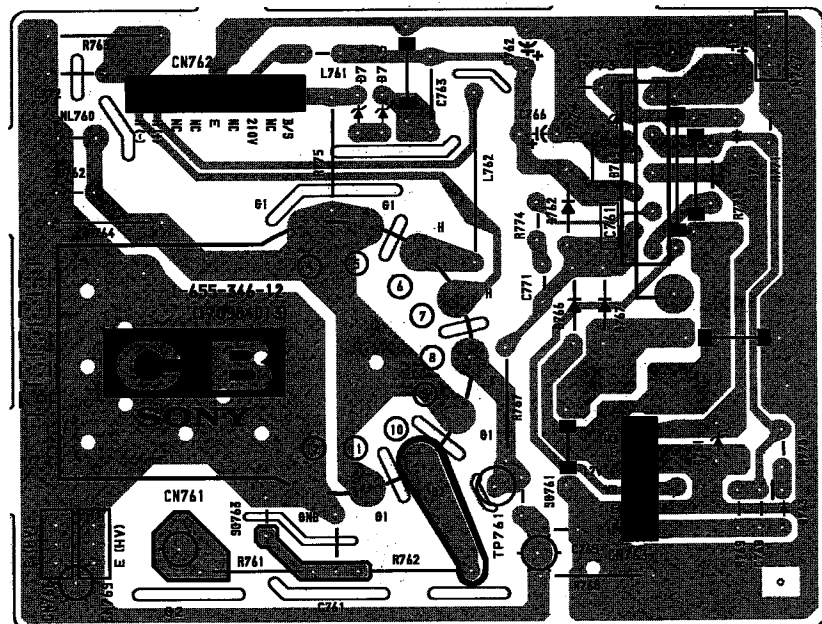

4-3. SEMICONDUCTORS

CAT51C262-ZS
MSM51C262-ZS

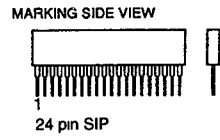

MB40176PF-G-BND-EF

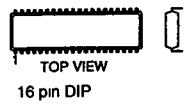

PA0053B
Z8622812PSC

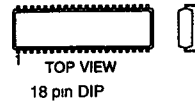

TDA6101Q

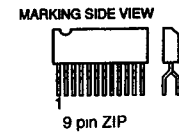

DTC323TS
2SA1175-HFE
2SC2785-HFE

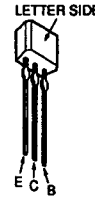

2SA1837
2SC4793
2SD2348(LBSONY-2)



D1N20R
ERA85-009
ERC91-02TP11
RD10ESB2
RD11ESB2
RD13ESB2
RD15ESB2
RD18ESB2
RD2.0ESB2
RD2.2ESB2
RD22ESB3
RD24ESB
RD3.3ESB2
RD3.9ESB2
RD33ESB1
RD39ESB2
RD5.1ESB1
RD5.1ESB2
RD5.6ESB1
RD5.6ESB2
RD8.2ESB2
RD9.1ESL
11ES2
1SS119-25

EGP-20G

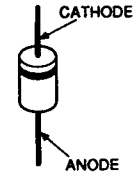

CXA1477AS
CXA1855S

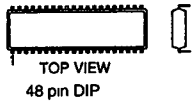

MB86144BPF-G-BND

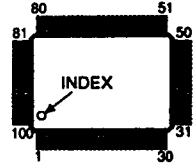

PM0002B

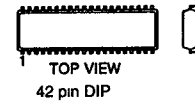

TDA7265

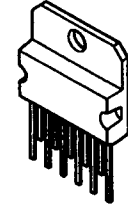

IRFI640LF

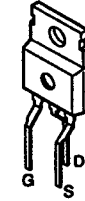

2SB649A-C
2SC2688-LK

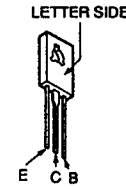

ERC06-15S
ERC91-02
RU-1C

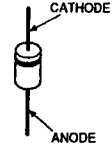

CXP85112B-SX377
CXP85332A-SX377

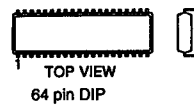

MCT7812CT

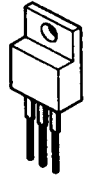

PQ05RF1
PQ09RA1



TDA8424

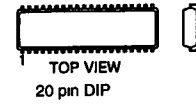

2SA1013-R-TPE6
2SA1208-S



2SC2878-AB

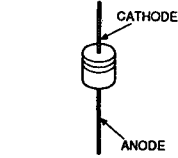

ERC38-06
V09G

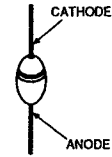

HD14053BFP

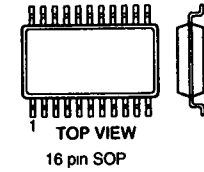

MN1280-S

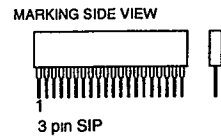

SBX1780-51

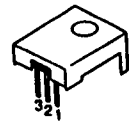

UPC339C

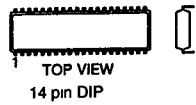

2SA1162-G
2SC1623-L5L6
2SD601A-Q



2SC4632LS-CB7
2SD1877-CA

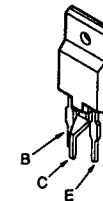

D1NL20
D1NL40-TR2
D2L40-TA
EL1Z
ERD28-08S
GP08D
RGP02-20EL-6394
1SS83

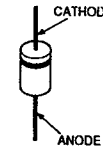

HVU359TRF
MA110
1T363

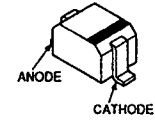

LM7912CT
NJM7905FA
MC7905CT

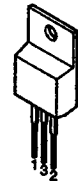

MN1382S

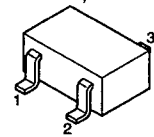

STK392-010

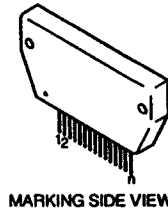

UPC574J

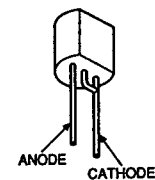

2SA1221-L
2SB733-34
2SD774-34

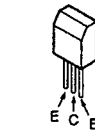

2SC4834M



D2S4MF

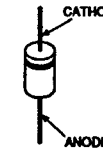

RD13M-B3
RD3.3M-B1
RD3.9M-B1
RD4.7M-B2
RD5.1M-B2
RD5.6M-B2

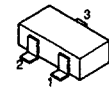

M5218AP
ST24C01CB1
ST24C04CB1
UPC358C

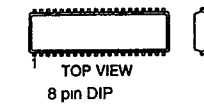

NJM2058D

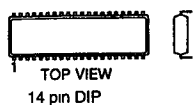

STV9379

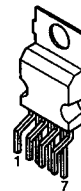

UPC78N05H



2SA1492M-OPY

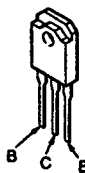

D10SBS4-F
D4SBS4-F
LN4SB60-F



D8LC40-F



SLR-325VCT31

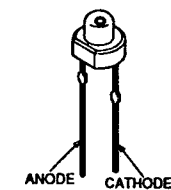

MB3512PFQ



NJM7805FA
NJM7812FA
NJM78M09FA
TA7805S
TA7812S

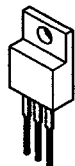

TC7SU04F

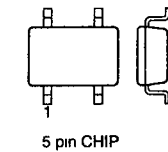

DTC124ES
2SC2458-YGR

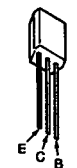

DAN202K



DAP202K



TDA6101Q

MARKING SIDE VIEW

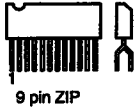

9 pin ZIP

TDA7265

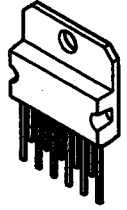

TDA8424



TOP VIEW
20 pin DIP

UPC339C

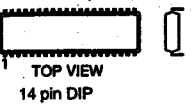

TOP VIEW
14 pin DIP

UPC574J

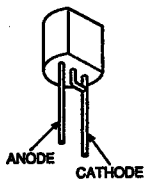

ANODE CATHODE

UPC78N05H



1 2 3

DTC124ES
2SC2458-YGR



E C B

DTC323TS
2SA1175-HFE
2SC2785-HFE



E C B

IRFI640LF

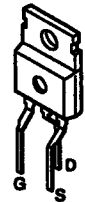

G D S

2SA1013-R-TPE6
2SA1208-S



E C B

2SA1162-G
2SC1623-L5L6
2SD601A-Q



B C E

2SA1221-L
2SB733-34
2SD774-34



E C B

2SA1492M-OPY

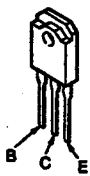

B C E

2SA1837
2SC4793
2SD2348(LBSONY-2)



B C E

2SB649A-C
2SC2688-LK

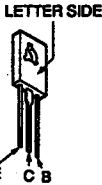

E C B

2SC2878-AB



E C B

2SC4632LS-CB7
2SD1877-CA

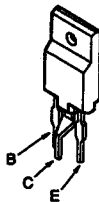

B C E

2SC4834M



B C E

D10SBS4-F
D4SBS4-F
LN4SB60-F



B C E

D1N20R
ERA85-009
ERC91-02TP11
RD10ESB2
RD11ESB2
RD13ESB2
RD15ESB2
RD18ESB2
RD2.0ESB2
RD2.2ESB2
RD22ESB3
RD24ESB
RD3.3ESB2
RD3.9ESB2
RD33ESB1
RD39ESB2
RD5.1ESB1
RD5.1ESB2
RD5.6ESB1
RD5.6ESB2
RD8.2ESB2
RD9.1ESL
11ES2
1SS119-25

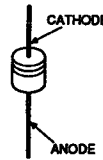

CATHODE
ANODE

D1NL20
D1NL40-TR2
D2L40-TA
EL1Z
ERD28-08S
GP08D
RGP02-20EL-6394
1SS83

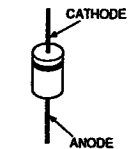

CATHODE
ANODE

D2S4MF

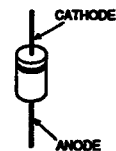

CATHODE
ANODE

D8LC40-F



DAN202K

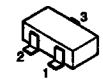

DAP202K

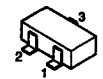

EGP-20G

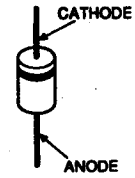

CATHODE
ANODE

ERC06-15S
ERC91-02
RU-1C

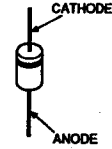

CATHODE
ANODE

ERC38-06
V09G

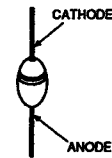

CATHODE
ANODE

HVU359TRF
MA110
1T363

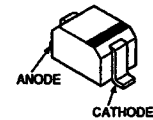

ANODE CATHODE

RD13M-B3
RD3.3M-B1
RD3.9M-B1
RD4.7M-B2
RD5.1M-B2
RD5.6M-B2



SLR-325VCT31

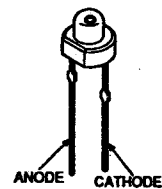

ANODE CATHODE

SECTION 5 EXPLODED VIEWS

NOTE:

- Items with no part number and no description are not stocked because they are seldom required for routine service

- The construction parts of an assembled part are indicated with a collation number in the remark column.

- Items marked " * " are not stocked since they are seldom required for routine service Some delay should be anticipated when ordering these items

The components identified by shading and mark ▲ are critical for safety
Replace only with part number specified

Les composants identifiés par une trame et une marque ▲ sont critiques pour la sécurité
Ne les remplacer que par une pièce portant le numéro spécifique

5-1. SCREEN AND CONTROL BLOCK

- 7-685-648-79 +BVTP 3X12
- △ 7-685-661-79 +BVTP 4X12
- 7-685-663-79 +BVTP 4X16
- ◆ 7-685-666-79 +BVTP 4X30

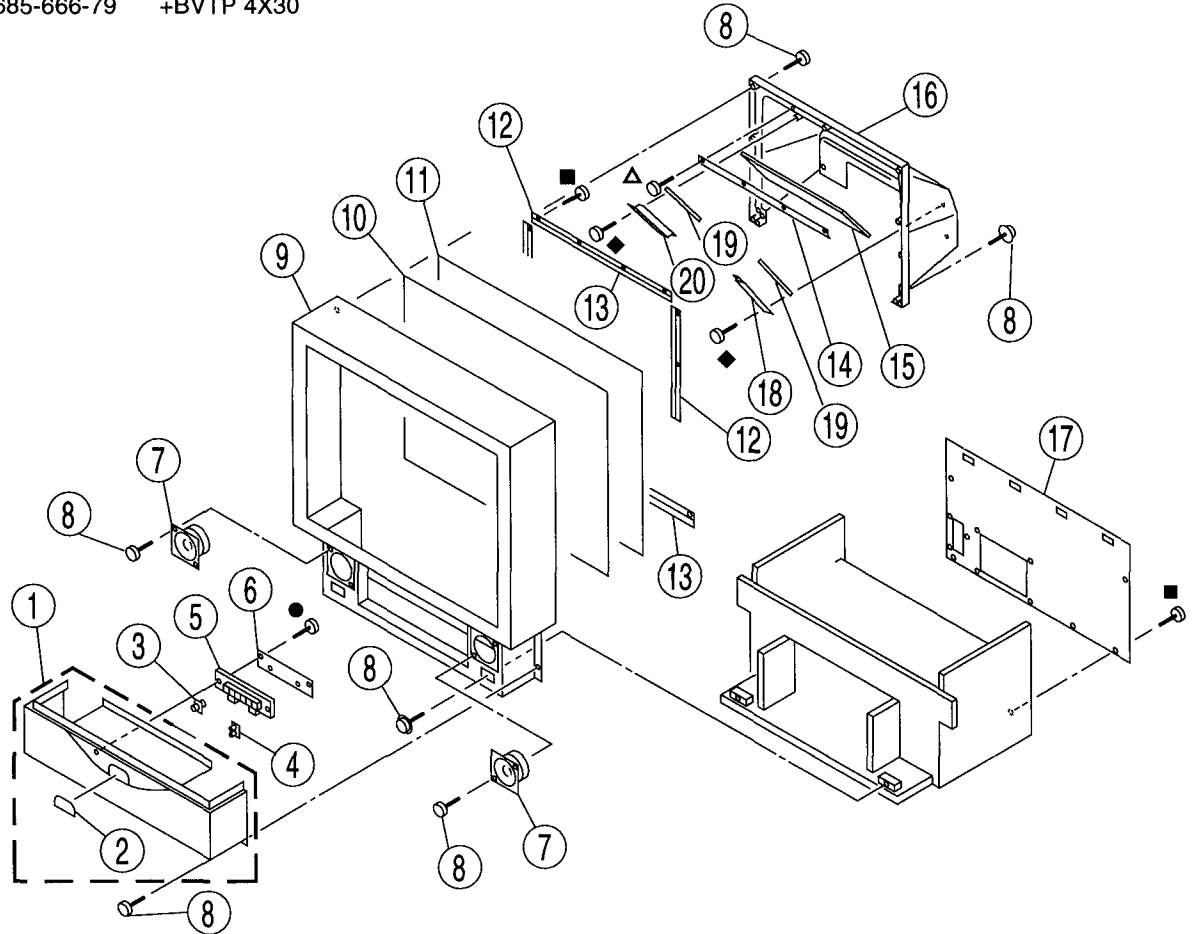

REF NO	PART NO	DESCRIPTION	REMARK	REF NO	PART NO	DESCRIPTION	REMARK
1	X-4032-545-1	PANEL ASSY, CONTROL		13	4-036-091-31	HOLDER (L), SCREEN	
2	4-048-000-01	DOOR, CONTROL		14	* 4-037-351-01	HOLDER, MIRROR	
3	4-047-999-01	FILTER, REMOTE			* 4-037-351-01	HOLDER, MIRROR	
4	4-047-998-01	GUIDE, LIGHT, LED		15	4-047-861-01	MIRROR (41), REFLECTION	
5	4-048-001-01	BUTTON, MULTI		16	X-4032-607-1	COVER, MIRROR	
6	* A-1372-099-A	HA BOARD, COMPLETE		17	* 4-047-837-01	PLATE (41), REAR	
7	1-504-785-11	SPEAKER (10CM)		18	* 4-049-096-01	HOLDER (RIGHT), SIDE	(KP-46S17/46S25/53S17/53S25)
8	4-041-164-11	SCREW (4X20), TAPPING		19	* 4-049-098-01	CUSHION	(KP-46S17/46S25/53S17/53S25)
9	X-4032-546-1	BEZNET ASSY		20	* 4-049-097-01	HOLDER (LEFT), SIDE	(KP-46S17/46S25/53S17/53S25)
10	4-034-053-01	PLATE (L), DIFFUSION					
11	4-047-943-11	PLATE (F), DIFFUSION					
12	4-036-092-01	HOLDER (S), SCREEN					

5-2. MIRROR COVER AND POWER BLOCK

- 7-685-648-79 +BVTP 3X12
- ▲ 7-685-661-79 +BVTP 4X12
- 7-685-663-79 +BVTP 4X16
- ◆ 7-685-666-79 +BVTP 4X30

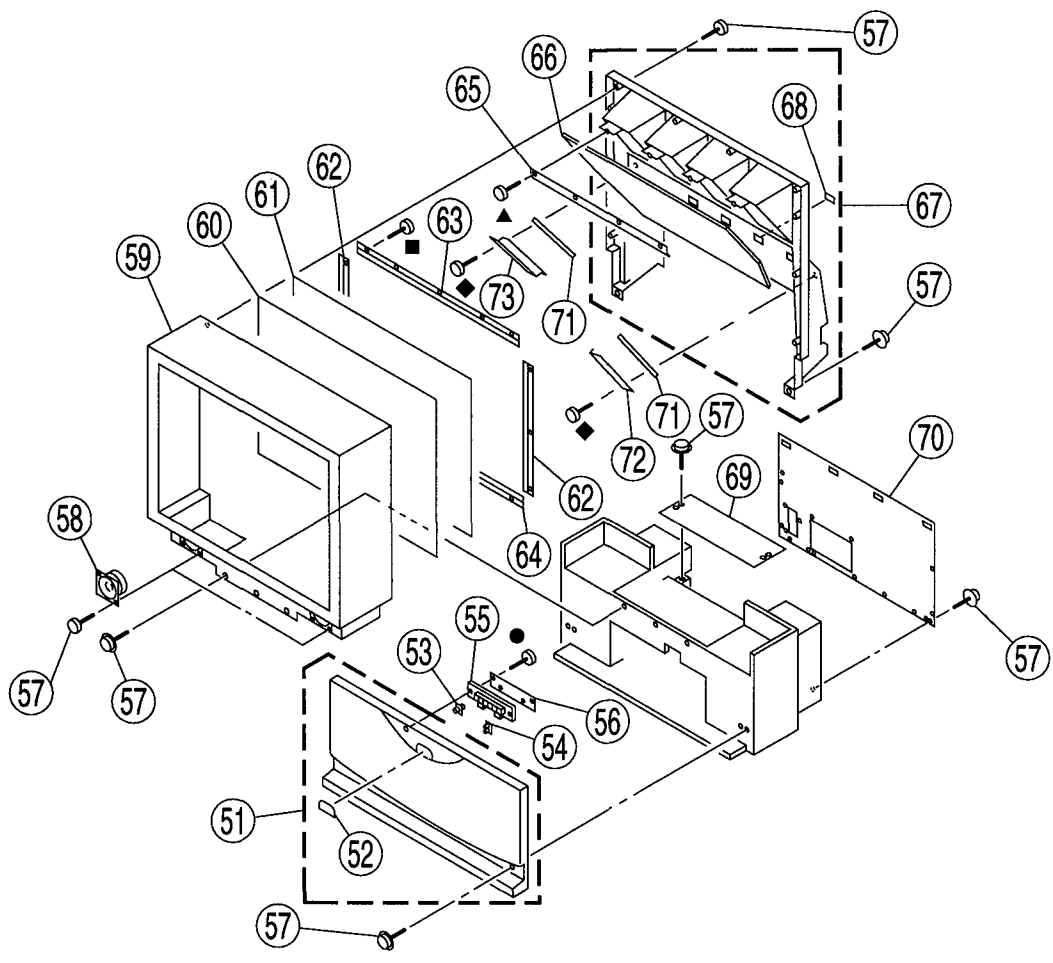

REF NO.	PART NO	DESCRIPTION	REMARK	REF NO	PART NO	DESCRIPTION	REMARK
51	X-4032-614-2	GRILLE ASSY, SPEAKER		52	63	* 4-048-159-01	HOLDER (L), SCREEN (KP-46S17/46S25)
52	4-048-000-01	DOOR, CONTROL				* 4-048-159-11	HOLDER (L), SCREEN (KP-53S17/53S25)
53	4-047-999-01	FILTER, REMOTE		64	* 4-048-159-21	HOLDER (L), SCREEN (KP-46S17/46S25)	
54	4-047-998-01	GUIDE, LIGHT, LED				* 4-048-159-31	HOLDER (L), SCREEN (KP-53S17/53S25)
55	4-048-001-01	BUTTON, MULTI		65	4-036-092-01	HOLDER, MIRROR	
56	* A-1372-099-A	HA BOARD, COMPLETE		66	4-048-181-01	MIRROR (46), REFLECTION (KP-46S17/46S25)	
57	4-041-164-11	SCREW (4X20), TAPPING				4-048-181-01	MIRROR (53), REFLECTION (KP-53S17/53S25)
58	1-504-785-11	SPEAKER (10CM)		67	* X-4032-619-3	COVER ASSY, MIRROR (KP-46S17/46S25)	
59	X-4032-617-2	BEZNET ASSY (46S) (KP-46S17/46S25)				* X-4032-620-3	COVER ASSY, MIRROR (KP-53S17/53S25)
	X-4032-618-1	BEZNET ASSY (53S) (KP-53S17/53S25)		69	* 4-048-160-01	PLATE, SHIELD (KP-46S17/46S25)	
60	4-036-466-11	PLATE (L), DIFFUSION (KP-53S17/53S25)				* 4-048-161-01	PLATE, SHIELD (KP-53S17/53S25)
	4-037-360-11	PLATE (L), DIFFUSION (KP-46S17/46S25)		70	* 4-048-168-01	PLATE, REAR (KP-53S17/53S25)	
61	4-036-469-01	PLATE (F), DIFFUSION (KP-53S17/53S25)				* 4-048-169-01	PLATE, REAR (KP-46S17/46S25)
	4-048-205-11	PLATE (F), DIFFUSION (KP-46S17/46S25)		71	* 4-049-098-01	CUSHION	
62	* 4-048-152-01	HOLDER (S), SCREEN (KP-46S17/46S25)		72	* 4-049-096-01	HOLDER (RIGHT), SIDE	
	* 4-048-152-11	HOLDER (S), SCREEN (KP-53S17/53S25)		73	* 4-049-097-01	HOLDER (LEFT), SIDE	

The components identified by shading and mark Δ are critical for safety. Replace only with part number specified.

Les composants identifiés par une trame et une marque Δ sont critiques pour la sécurité. Ne les remplacer que par une pièce portant le numéro spécifié.

5-3. DC AND E BLOCK

- 7-685-648-79 +BVTP 3X12
- 7-685-663-79 +BVTP 4X16

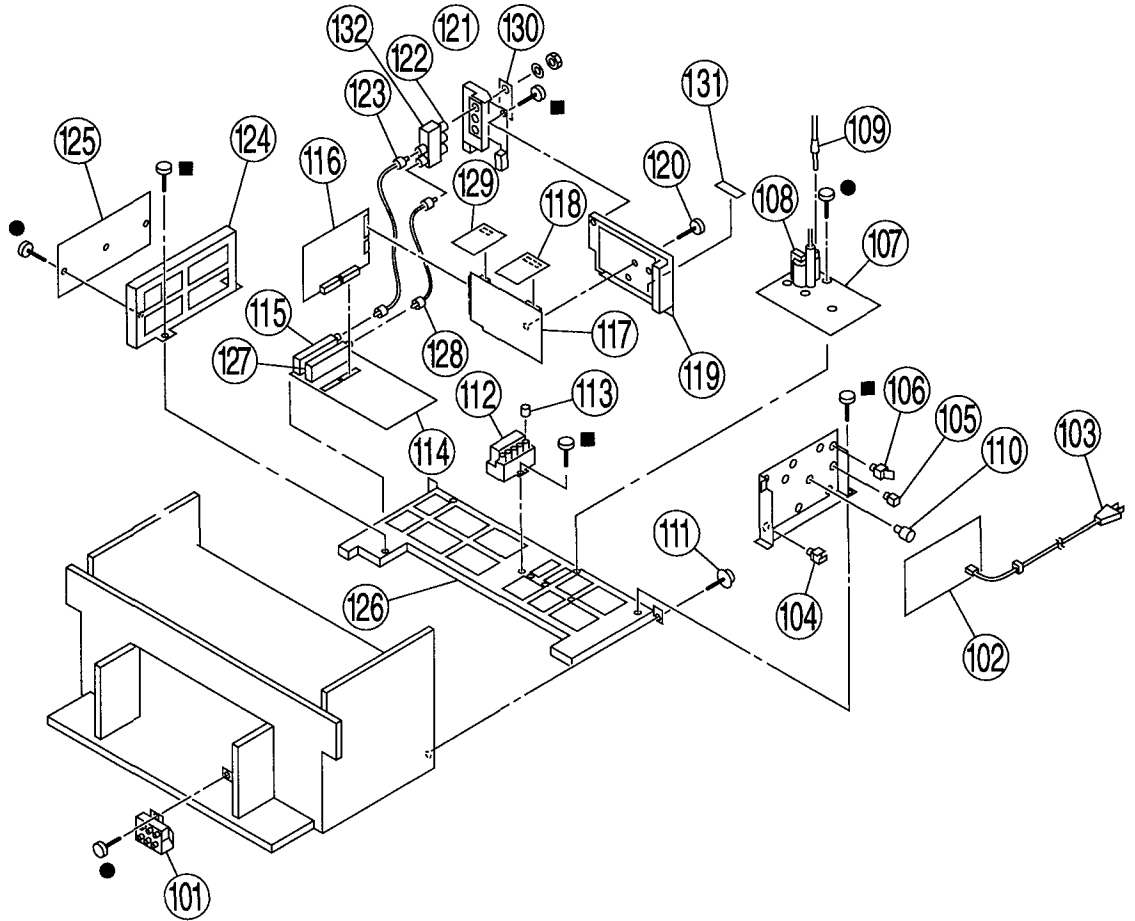

REF NO	PART NO	DESCRIPTION	REMARK	REF NO	PART NO	DESCRIPTION	REMARK
101	Δ 1-223-925-21	RESISTOR ASSY (HIGH-VOLTAGE)		117	* A-1373-511-A	U BOARD, COMPLETE (KP-46S17/53S17)	
102	* A-1316-212-A	G BOARD, COMPLETE			* A-1373-562-A	U BOARD, COMPLETE	
103	Δ 1-769-837-11	CORD, POWER (WITH NOISE FILTER)	(7.0A/125V)				(KP-41T25/46S25/53S25)
104	* 3-659-682-11	HOLDER, PC BOARD		118	* A-1195-062-A	P BOARD, COMPLETE	
105	* 4-382-848-02	HOLDER, PCB		119	4-047-951-01	TERMINAL BOARD (A)	
106	* 3-703-141-11	HOLDER, PCB		120	4-041-165-01	SCREW (3X12), TAPPING, +BV	
107	* A-1341-885-A	E BOARD, COMPLETE		121	4-047-952-11	TERMINAL BOARD (B)	
108	Δ 1-453-189-11	TRANSFORMER ASSY, FLYBACK	(NX2631//A4S)	122	1-561-306-00	JACK, PIN (F) (KP-46S17/53S17)	
109	Δ 1-900-211-34	LEAD ASSY, HV		123	1-556-945-21	CABLE, P-P	
110	* 3-687-542-41	SPACER, PC BOARD SPACE		124	* 4-047-950-01	BRACKET, D PC BOARD	
111	4-041-164-11	SCREW (4X20), TAPPING		125	* A-1346-296-A	D BOARD, COMPLETE	
112	Δ 8-598-955-00	BLOCK ASSY, HIGH-VOLTAGE		126	* 4-047-949-01	BRACKET, MAIN PC BOARD	
113	4-373-137-01	CAP (Z), RUBBER		127	Δ 8-598-047-11	TUNER, ET (BTF-LA401)	(KP-41T25/46S25/53S25)
114	* A-1297-605-A	A BOARD, COMPLETE (KP-46S17/53S17)		128	1-557-056-41	CABLE, P-P	
	* A-1297-813-A	A BOARD, COMPLETE (KP-46S25/53S25)		129	* A-1394-681-A	TR2 BOARD, COMPLETE	
	* A-1297-814-A	A BOARD, COMPLETE (KP-41T25)		130	4-047-937-01	LABEL (B), TERMINAL	(KP-46S17/46S25/53S17/53S25)
115	Δ 8-598-254-00	TUNER (BTF-WA402)		131	4-049-665-01	LABEL, IN/OUT	
116	* A-1306-497-A	M BOARD, COMPLETE (KP-41T25)		132	1-417-178-11	SELECTOR, ANTENA (AS-2)	(KP-46S17/46S25/53S17/53S25)
	* A-1306-498-A	M BOARD, COMPLETE (KP-46S17/53S17)					
	* A-1306-530-A	M BOARD, COMPLETE (KP-46S25/53S25)					

The components identified by shading and mark Δ , are critical for safety
 Replace only with part number specified

Les composants identifiés par une trame et une marque Δ sont critiques pour la sécurité
 Ne les remplacer que par une pièce portant le numéro spécifié.

5-4. SHIELD AND MIRROR HOLDER BLOCK

■ 7-685-663-79 +BVTP 4X16

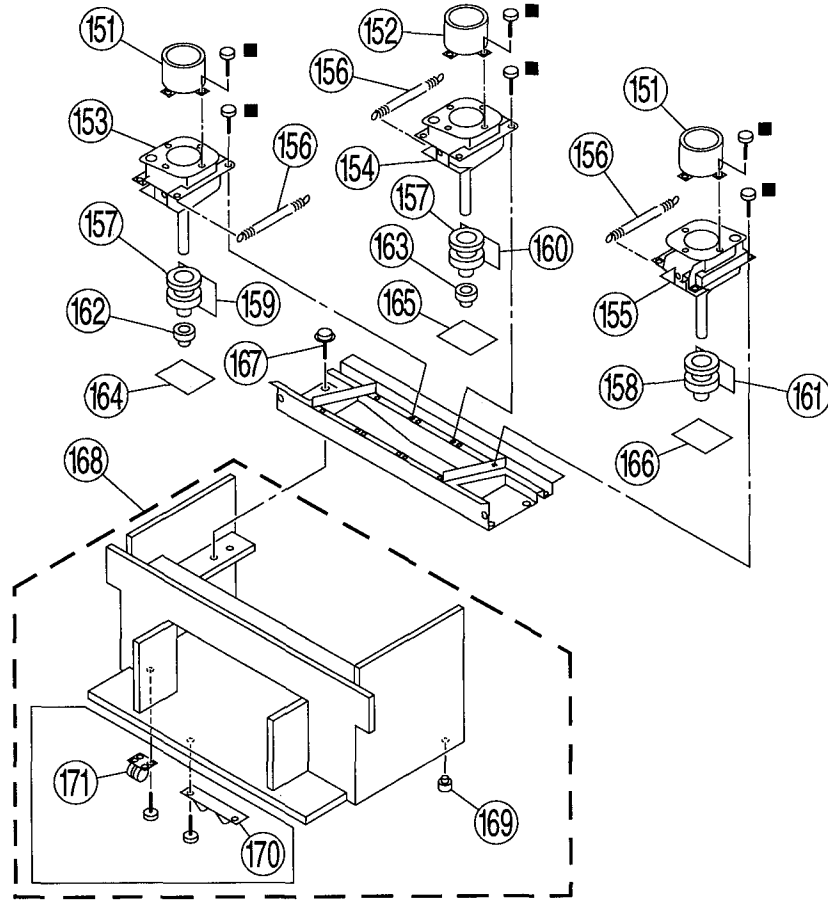

REF NO	PART NO	DESCRIPTION	REMARK	REF NO	PART NO	DESCRIPTION	REMARK
151	4-034-057-01	LENS (LINNIT)		161	* A-1390-491-A	ZB BOARD, COMPLETE	
152	4-034-057-11	LENS (LINNIT)		162	Δ 1-452-790-21	NECK ASSY (KP-41T25)	
153	Δ 8-736-077-15	PICTURE TUBE 07MAC2 (R) (KP-41T25/46S17/46S25)		163	Δ 1-452-790-11	NECK ASSY (KP-41T25)	
153	Δ 8-736-077-25	PICTURE TUBE 07MAC3(R) (KP-53S17/53S25)		164	* A-1331-498-A	CR BOARD, COMPLETE	
154	Δ 8-736-075-05	PICTURE TUBE 07MAC2(G)		165	* A-1331-499-A	CG BOARD, COMPLETE	
155	Δ 8-736-076-15	PICTURE TUBE 07MAC2 (B) (KP-41T25/46S17/46S25)		166	* A-1331-500-A	CB BOARD, COMPLETE	
	Δ 8-736-076-25	PICTURE TUBE 07MAC3(B) (KP-53S17/53S25)		167	4-052-894-01	SCREW (4X20), TAPPING	
156	4-048-142-01	SPRING, TENSION		168	* X-4032-547-1	CABINET ASSY, BOTTOM (KP-41T25)	169
157	Δ 8-451-463-11	DEFLECTION YOKE (Y829PA2N)			* X-4032-615-1	CABINET ASSY, BOTTOM (KP-46S17/46S25)	171,170
158	Δ 8-451-463-21	DEFLECTION YOKE (Y829PA2N2)		168	* X-4032-616-1	CABINET ASSY, BOTTOM (KP-53S17/53S25)	171,170
159	* A-1390-487-A	ZR BOARD, COMPLETE (KP-41T25)		169	4-047-987-01	FOOT (KP-41T25)	
	* A-1390-513-A	ZR BOARD, COMPLETE (KP-46S17/46S25/53S17/53S25)		170	4-048-175-01	FOOT, PLASTIC (KP-46S17/46S25/53S17/53S25)	
160	* A-1390-489-A	ZG BOARD, COMPLETE (KP-41T25)		171	4-040-755-01	CASTER (DIA 30) (KP-46S17/46S25/53S17/53S25)	
	* A-1390-512-A	ZG BOARD, COMPLETE (KP-46S17/46S25/53S17/53S25)					

SECTION 6 ELECTRICAL PARTS LIST



NOTE:

Les composants identifiés par une trame et une marque Δ sont critiques pour la sécurité. Ne les remplacer que par une pièce portant le numéro spécifié.

The components identified by shading and mark Δ are critical for safety. Replace only with part number specified.

- The components identified by \boxtimes in this manual have been carefully factory-selected for each set in order to satisfy regulations regarding X-ray radiation. Should replacement be required, replace only with the value originally used.
- Items marked " * " are not stocked since they are seldom required for routine service. Some delay should be anticipated when ordering these items
- All variable and adjustable resistors have characteristic curve B, unless otherwise noted.

When indicating parts by reference number, please include the board name.

- CAPACITORS
PF : $\mu\mu$ F
- There are some cases the reference number on one board overlaps on the other board. Therefore, when ordering parts by the reference number, please include the board name.

RESISTORS

- All resistors are in ohms
- F : nonflammable

REF NO	PART NO	DESCRIPTION	REMARK	REF NO	PART NO.	DESCRIPTION	REMARK
* A-1195-062-A P BOARD, COMPLETE *****				C3252	1-163-103-00	CERAMIC CHIP 27PF	5% 50V
<CAPACITOR>				C3253	1-163-101-00	CERAMIC CHIP 22PF	5% 50V
C3201	1-126-967-11	ELECT 47MF	20% 16V	C3254	1-163-141-00	CERAMIC CHIP 0.001MF	5% 50V
C3203	1-164-004-11	CERAMIC CHIP 0.1MF	10% 25V	C3255	1-163-101-00	CERAMIC CHIP 22PF	5% 50V
C3204	1-126-964-11	ELECT 10MF	20% 50V	C3256	1-164-232-11	CERAMIC CHIP 0.01MF	10% 50V
C3205	1-126-964-11	ELECT 10MF	20% 50V	C3257	1-163-117-00	CERAMIC CHIP 100PF	5% 50V
C3206	1-126-964-11	ELECT 10MF	20% 50V	C3258	1-163-113-00	CERAMIC CHIP 68PF	5% 50V
C3207	1-163-117-00	CERAMIC CHIP 100PF	5% 50V	C3259	1-163-111-00	CERAMIC CHIP 56PF	5% 50V
C3208	1-163-117-00	CERAMIC CHIP 100PF	5% 50V	C3260	1-163-119-00	CERAMIC CHIP 120PF	5% 50V
C3209	1-126-962-11	ELECT 3.3MF	20% 50V	C3261	1-163-141-00	CERAMIC CHIP 0.001MF	5% 50V
C3210	1-126-967-11	ELECT 47MF	20% 16V	C3263	1-163-141-00	CERAMIC CHIP 0.001MF	5% 50V
C3212	1-126-962-11	ELECT 3.3MF	20% 50V	C3264	1-165-319-11	CERAMIC CHIP 0.1MF	50V
C3213	1-164-346-11	CERAMIC CHIP 1MF	16V	C3265	1-163-141-00	CERAMIC CHIP 0.001MF	5% 50V
C3214	1-164-346-11	CERAMIC CHIP 1MF	16V	C3266	1-163-141-00	CERAMIC CHIP 0.001MF	5% 50V
C3215	1-164-346-11	CERAMIC CHIP 1MF	16V	C3267	1-163-141-00	CERAMIC CHIP 0.001MF	5% 50V
C3216	1-164-005-11	CERAMIC CHIP 0.47MF	25V	C3268	1-163-141-00	CERAMIC CHIP 0.001MF	5% 50V
C3217	1-164-346-11	CERAMIC CHIP 1MF	16V	C3269	1-163-141-00	CERAMIC CHIP 0.001MF	5% 50V
C3218	1-164-346-11	CERAMIC CHIP 1MF	16V	C3270	1-165-319-11	CERAMIC CHIP 0.1MF	50V
C3219	1-126-935-11	ELECT 470MF	20% 16V	C3271	1-165-319-11	CERAMIC CHIP 0.1MF	50V
C3220	1-164-346-11	CERAMIC CHIP 1MF	16V	C3272	1-165-319-11	CERAMIC CHIP 0.1MF	50V
C3221	1-164-346-11	CERAMIC CHIP 1MF	16V	C3273	1-163-109-00	CERAMIC CHIP 47PF	5% 50V
C3222	1-164-336-11	CERAMIC CHIP 0.33MF	25V	C3274	1-163-101-00	CERAMIC CHIP 22PF	5% 50V
C3223	1-164-336-11	CERAMIC CHIP 0.33MF	25V	C3275	1-163-101-00	CERAMIC CHIP 22PF	5% 50V
C3224	1-164-222-11	CERAMIC CHIP 0.22MF	25V	C3276	1-163-111-00	CERAMIC CHIP 56PF	5% 50V
C3225	1-164-222-11	CERAMIC CHIP 0.22MF	25V	C3277	1-163-101-00	CERAMIC CHIP 22PF	5% 50V
C3226	1-164-005-11	CERAMIC CHIP 0.47MF	25V	C3278	1-163-101-00	CERAMIC CHIP 22PF	5% 50V
C3227	1-164-346-11	CERAMIC CHIP 1MF	16V	C3279	1-163-141-00	CERAMIC CHIP 0.001MF	5% 50V
C3228	1-163-117-00	CERAMIC CHIP 100PF	5% 50V	C3280	1-126-964-11	ELECT 10MF	20% 50V
C3229	1-163-093-00	CERAMIC CHIP 10PF	5% 50V	C3282	1-164-346-11	CERAMIC CHIP 1MF	16V
C3230	1-163-141-00	CERAMIC CHIP 0.001MF	5% 50V	<CONNECTOR>			
C3231	1-163-125-00	CERAMIC CHIP 220PF	5% 50V	CN150	1-573-297-21	CONNECTOR, BOARD TO BOARD 18P	
C3232	1-163-117-00	CERAMIC CHIP 100PF	5% 50V	<DIODE>			
C3233	1-164-232-11	CERAMIC CHIP 0.01MF	10% 50V	D3202	8-719-031-68	DIODE HVU359TRF	
C3234	1-164-232-11	CERAMIC CHIP 0.01MF	10% 50V	D3203	8-719-404-46	DIODE MA110	
C3235	1-164-232-11	CERAMIC CHIP 0.01MF	10% 50V	D3208	8-719-110-17	DIODE RD10ESB2	
C3236	1-164-232-11	CERAMIC CHIP 0.01MF	10% 50V	D3209	8-719-110-17	DIODE RD10ESB2	
C3237	1-164-232-11	CERAMIC CHIP 0.01MF	10% 50V	<IC>			
C3238	1-163-101-00	CERAMIC CHIP 22PF	5% 50V	IC3200	8-759-288-13	IC MSM51C262-ZS	
C3239	1-163-141-00	CERAMIC CHIP 0.001MF	5% 50V	IC3201	8-759-093-29	IC MB86144BPF-G-BND	
C3240	1-163-101-00	CERAMIC CHIP 22PF	5% 50V	IC3202	8-759-093-28	IC MB40176PF-G-BND-EF	
C3241	1-163-103-00	CERAMIC CHIP 27PF	5% 50V	IC3203	8-759-093-28	IC MB40176PF-G-BND-EF	
C3242	1-164-232-11	CERAMIC CHIP 0.01MF	10% 50V	IC3204	8-759-093-25	IC MB3512PFQ	
C3243	1-163-117-00	CERAMIC CHIP 100PF	5% 50V	IC3205	8-759-243-19	IC TC7SU04F	
C3244	1-163-113-00	CERAMIC CHIP 68PF	5% 50V	<COIL>			
C3245	1-164-232-11	CERAMIC CHIP 0.01MF	10% 50V	L3201	1-410-470-11	INDUCTOR 10UH	
C3246	1-164-232-11	CERAMIC CHIP 0.01MF	10% 50V	L3202	1-408-424-00	INDUCTOR 180UH	
C3247	1-163-033-91	CERAMIC CHIP 0.022MF	50V				
C3248	1-163-125-00	CERAMIC CHIP 220PF	5% 50V				
C3249	1-163-117-00	CERAMIC CHIP 100PF	5% 50V				
C3250	1-163-113-00	CERAMIC CHIP 68PF	5% 50V				
C3251	1-164-232-11	CERAMIC CHIP 0.01MF	10% 50V				



REF NO.	PART NO	DESCRIPTION	REMARK
L3203	1-408-424-00	INDUCTOR 180UH	
L3204	1-410-476-11	INDUCTOR 33UH	
L3205	1-410-470-11	INDUCTOR 10UH	
L3206	1-410-387-11	INDUCTOR 33UH	
L3207	1-410-387-11	INDUCTOR 33UH	
L3208	1-410-387-11	INDUCTOR 33UH	
L3209	1-410-387-11	INDUCTOR 33UH	
<TRANSISTOR>			
Q3201	8-729-216-22	TRANSISTOR 2SA1162-G	
Q3202	8-729-422-27	TRANSISTOR 2SD601A-Q	
Q3203	8-729-216-22	TRANSISTOR 2SA1162-G	
Q3204	8-729-216-22	TRANSISTOR 2SA1162-G	
Q3206	8-729-422-27	TRANSISTOR 2SD601A-Q	
Q3207	8-729-216-22	TRANSISTOR 2SA1162-G	
Q3208	8-729-422-27	TRANSISTOR 2SD601A-Q	
Q3209	8-729-216-22	TRANSISTOR 2SA1162-G	
Q3210	8-729-216-22	TRANSISTOR 2SA1162-G	
<RESISTOR>			
R3201	1-216-097-91	METAL GLAZE 100K	5% 1/10W
R3202	1-216-073-00	METAL GLAZE 10K	5% 1/10W
R3203	1-216-025-91	METAL GLAZE 100	5% 1/10W
R3204	1-216-025-91	METAL GLAZE 100	5% 1/10W
R3205	1-216-121-91	METAL GLAZE 1M	5% 1/10W
R3207	1-216-295-91	CONDUCTOR, CHIP	
R3208	1-216-097-91	METAL GLAZE 100K	5% 1/10W
R3209	1-216-079-00	METAL GLAZE 18K	5% 1/10W
R3210	1-216-089-91	METAL GLAZE 47K	5% 1/10W
R3211	1-216-073-00	METAL GLAZE 10K	5% 1/10W
R3212	1-216-073-00	METAL GLAZE 10K	5% 1/10W
R3213	1-216-075-00	METAL GLAZE 12K	5% 1/10W
R3214	1-216-121-91	METAL GLAZE 1M	5% 1/10W
R3215	1-216-057-00	METAL GLAZE 2 2K	5% 1/10W
R3216	1-216-057-00	METAL GLAZE 2 2K	5% 1/10W
R3217	1-216-057-00	METAL GLAZE 2.2K	5% 1/10W
R3218	1-216-049-91	METAL GLAZE 1K	5% 1/10W
R3219	1-216-049-91	METAL GLAZE 1K	5% 1/10W
R3220	1-216-049-91	METAL GLAZE 1K	5% 1/10W
R3221	1-216-655-11	METAL CHIP 1 5K	0 50% 1/10W
R3222	1-216-655-11	METAL CHIP 1.5K	0 50% 1/10W
R3223	1-216-025-91	METAL GLAZE 100	5% 1/10W
R3224	1-216-049-91	METAL GLAZE 1K	5% 1/10W
R3225	1-216-025-91	METAL GLAZE 100	5% 1/10W
R3226	1-216-085-00	METAL GLAZE 33K	5% 1/10W
R3227	1-216-647-11	METAL CHIP 680	0 50% 1/10W
R3228	1-216-045-00	METAL GLAZE 680	5% 1/10W
R3229	1-216-073-00	METAL GLAZE 10K	5% 1/10W
R3230	1-216-073-00	METAL GLAZE 10K	5% 1/10W
R3231	1-216-001-00	METAL GLAZE 10	5% 1/10W
R3232	1-216-083-00	METAL GLAZE 27K	5% 1/10W
R3233	1-216-049-91	METAL GLAZE 1K	5% 1/10W
R3234	1-216-651-11	METAL CHIP 1K	0 50% 1/10W
R3235	1-216-043-91	METAL GLAZE 560	5% 1/10W
R3236	1-216-065-00	METAL GLAZE 4 7K	5% 1/10W
R3237	1-216-043-91	METAL GLAZE 560	5% 1/10W
R3238	1-216-049-91	METAL GLAZE 1K	5% 1/10W
R3239	1-216-043-91	METAL GLAZE 560	5% 1/10W
R3241	1-216-057-00	METAL GLAZE 2 2K	5% 1/10W
R3242	1-216-049-91	METAL GLAZE 1K	5% 1/10W
R3243	1-216-025-91	METAL GLAZE 100	5% 1/10W
R3244	1-216-025-91	METAL GLAZE 100	5% 1/10W
R3245	1-216-025-91	METAL GLAZE 100	5% 1/10W
R3246	1-216-069-00	METAL GLAZE 6 8K	5% 1/10W
R3247	1-216-063-91	METAL GLAZE 3 9K	5% 1/10W
R3248	1-216-295-91	CONDUCTOR, CHIP	
R3249	1-216-057-00	METAL GLAZE 2 2K	5% 1/10W

REF NO	PART NO.	DESCRIPTION	REMARK
R3250	1-216-043-91	METAL GLAZE 560	5% 1/10W
R3251	1-216-049-91	METAL GLAZE 1K	5% 1/10W
R3252	1-216-043-91	METAL GLAZE 560	5% 1/10W
R3253	1-216-065-00	METAL GLAZE 4 7K	5% 1/10W
R3254	1-216-043-91	METAL GLAZE 560	5% 1/10W
R3255	1-216-041-00	METAL GLAZE 470	5% 1/10W
R3256	1-216-043-91	METAL GLAZE 560	5% 1/10W
R3259	1-216-298-00	METAL GLAZE 2 2	5% 1/10W
R3260	1-216-073-00	METAL GLAZE 10K	5% 1/10W
R3263	1-216-025-91	METAL GLAZE 100	5% 1/10W
R3264	1-216-025-91	METAL GLAZE 100	5% 1/10W
R3265	1-216-049-91	METAL GLAZE 1K	5% 1/10W
R3266	1-216-057-00	METAL GLAZE 2 2K	5% 1/10W
R3267	1-216-055-00	METAL GLAZE 1 8K	5% 1/10W
R3268	1-216-053-00	METAL GLAZE 1 5K	5% 1/10W
R3269	1-216-057-00	METAL GLAZE 2 2K	5% 1/10W
R3270	1-216-657-11	METAL CHIP 1 8K	0 50% 1/10W
R3271	1-216-655-11	METAL CHIP 1 5K	0.50% 1/10W
R3273	1-216-073-00	METAL GLAZE 10K	5% 1/10W
R3274	1-216-049-91	METAL GLAZE 1K	5% 1/10W
R3275	1-216-049-91	METAL GLAZE 1K	5% 1/10W
R3276	1-216-049-91	METAL GLAZE 1K	5% 1/10W
R3277	1-216-298-00	METAL GLAZE 2 2	5% 1/10W
<CRYSTAL>			
X3201	1-567-878-11	VIBRATOR, CRYSTAL	
X3202	1-567-878-11	VIBRATOR, CRYSTAL	

* A-1297-605-A		A BOARD, COMPLETE (KP-46S17/53S17)	

* A-1297-813-A		A BOARD, COMPLETE (KP-46S25/53S25)	

* A-1297-814-A		A BOARD, COMPLETE (KP-41T25)	

4-365-216-00	SPACER, MICA		
4-382-854-11	SCREW (M3X10), P, SW (+)		
7-322-065-19	RUBBER, SILICON RTV (KE490W)		
(KP-41T25/46S25/53S25)			
<CAPACITOR>			
C201	1-104-665-11	ELECT 100MF	20% 25V
C202	1-102-125-00	CERAMIC 0 0047MF	10% 50V
C203	1-130-489-00	FILM 0 033MF	5% 50V
C204	1-124-902-00	ELECT 0 47MF	20% 50V
C205	1-104-665-11	ELECT 100MF	20% 25V
C206	1-124-902-00	ELECT 0 47MF	20% 50V
C207	1-124-903-11	ELECT 1MF	20% 50V
C208	1-124-768-11	ELECT 4 7MF	20% 50V
C209	1-124-903-11	ELECT 1MF	20% 50V
C210	1-102-125-00	CERAMIC 0 0047MF	10% 50V
C211	1-130-489-00	FILM 0.033MF	5% 50V
C212	1-124-768-11	ELECT 4 7MF	20% 50V
C220	1-126-964-11	ELECT 10MF	20% 50V
C221	1-126-964-11	ELECT 10MF	20% 50V
C222	1-126-964-11	ELECT 10MF	20% 50V
C223	1-126-964-11	ELECT 10MF	20% 50V
C226	1-104-665-11	ELECT 100MF	20% 25V
C232	1-104-664-11	ELECT 47MF	20% 25V
C233	1-104-664-11	ELECT 47MF	20% 25V
C234	1-104-664-11	ELECT 47MF	20% 25V
C236	1-124-902-00	ELECT 0 47MF	20% 50V
C238	1-104-665-11	ELECT 100MF	20% 25V
C239	1-126-943-11	ELECT 2200MF	20% 25V



REF. NO.	PART NO.	DESCRIPTION	REMARK	REF. NO.	PART NO.	DESCRIPTION	REMARK
C240	1-126-943-11	ELECT	2200MF 20% 25V	D232	8-719-991-33	DIODE 1SS133T-77	
C241	1-137-399-11	FILM	0.1MF 5% 50V	D235	8-719-991-33	DIODE 1SS133T-77	
C242	1-137-399-11	FILM	0.1MF 5% 50V	D262	8-719-991-33	DIODE 1SS133T-77	
C243	1-137-399-11	FILM	0.1MF 5% 50V	D263	8-719-991-33	DIODE 1SS133T-77	
C244	1-104-665-11	ELECT	100MF 20% 25V	D264	8-719-991-33	DIODE 1SS133T-77	
C245	1-137-399-11	FILM	0.1MF 5% 50V	D501	8-719-991-33	DIODE 1SS133T-77	
C262	1-104-664-11	ELECT	47MF 20% 25V	D502	8-719-983-14	DIODE MTZJ-T-77-3.9	
C263	1-104-665-11	ELECT	100MF 20% 25V	D504	8-719-991-33	DIODE 1SS133T-77	
C264	1-104-665-11	ELECT	100MF 20% 25V	D505	8-719-991-33	DIODE 1SS133T-77	
C265	1-104-665-11	ELECT	100MF 20% 25V	D506	8-719-300-80	DIODE RU-1C	
C266	1-104-665-11	ELECT	100MF 20% 25V	D507	8-719-018-82	DIODE RGP02-20EL-6394	
C267	1-104-664-11	ELECT	47MF 20% 25V	D509	8-719-900-95	DIODE V09G	
C501	1-124-902-00	ELECT	0.47MF 20% 50V	D510	8-719-900-95	DIODE V09G	
C502	1-104-664-11	ELECT	47MF 20% 25V	D511	8-719-991-33	DIODE 1SS133T-77	
C503	1-137-370-11	FILM	0.01MF 5% 50V	D1001	8-719-982-24	DIODE MTZJ-33A	
C504	1-102-973-00	CERAMIC	100PF 5% 50V	D1002	8-719-110-88	DIODE RD39ESB2 (KP-41T25/46S25/53S25)	
C505	1-137-372-11	FILM	0.022MF 5% 50V			<IC>	
C506	1-123-024-21	ELECT	33MF 160V	IC201	8-759-135-80	IC uPC358C	
C507	1-107-368-11	FILM	0.047MF 10% 200V	IC202	8-759-090-21	IC TDA8424	
C508	1-107-638-11	ELECT	33MF 20% 160V	IC230	8-759-190-89	IC TDA7265	
C509	1-107-368-11	FILM	0.047MF 10% 200V	IC262	8-759-054-12	IC PQ09RA1	
C510	1-102-030-00	CERAMIC	330PF 10% 500V	IC263	8-759-504-46	IC PQ05RF1	
C511	1-137-414-11	FILM	0.0047MF 10% 100V	IC264	8-759-279-76	IC MCT7812CT	
C512	1-162-115-00	CERAMIC	330PF 10% 2KV	IC1001	8-759-300-71	IC HD14053BFP (KP-41T25/46S25/53S25)	
C513	1-136-598-11	FILM	3MF 5% 200V			<COIL>	
C514	1-136-613-11	FILM	0.0068MF 3% 2KV	L501	1-411-189-11	COIL, CHOKE 15mH	
C515	1-162-114-00	CERAMIC	0.0047MF 2KV	L503	1-406-832-11	COIL, HORIZONTAL LINEARITY (HLC)	
C516	1-107-719-11	ELECT	220MF 20% 50V	L1001	1-408-408-00	INDUCTOR 8.2UH	
C517	1-126-971-11	ELECT	470MF 20% 50V	L1002	1-408-408-00	INDUCTOR 8.2UH	
C518	1-126-971-11	ELECT	470MF 20% 50V	L1003	1-408-421-00	INDUCTOR 100UH	
C519	1-124-903-11	ELECT	1MF 20% 50V	L1004	1-408-408-00	INDUCTOR 8.2UH (KP-41T25/46S25/53S25)	
C1001	1-126-963-11	ELECT	4.7MF 20% 50V	L1006	1-408-408-00	INDUCTOR 8.2UH (KP-41T25/46S25/53S25)	
C1002	1-126-964-11	ELECT	10MF 20% 50V (KP-41T25/46S25/53S25)	L1007	1-408-408-00	INDUCTOR 8.2UH (KP-41T25/46S25/53S25)	
C1003	1-126-965-11	ELECT	22MF 20% 50V (KP-41T25/46S25/53S25)			<TRANSISTOR>	
C1004	1-126-952-11	ELECT	1000MF 20% 16V	Q220	8-729-927-14	TRANSISTOR DTC323TS	
C1005	1-104-665-11	ELECT	100MF 20% 25V	Q221	8-729-119-76	TRANSISTOR 2SA1175-HFE	
C1006	1-101-004-00	CERAMIC	0.01MF 50V	Q222	8-729-927-14	TRANSISTOR DTC323TS	
C1007	1-126-935-11	ELECT	470MF 20% 16V	Q223	8-729-119-76	TRANSISTOR 2SA1175-HFE	
C1008	1-101-004-00	CERAMIC	0.01MF 50V	Q230	8-729-119-78	TRANSISTOR 2SC2785-HFE	
C1009	1-126-964-11	ELECT	10MF 20% 50V (KP-41T25/46S25/53S25)	Q231	8-729-119-78	TRANSISTOR 2SC2785-HFE	
C1010	1-126-964-11	ELECT	10MF 20% 50V	Q232	8-729-119-78	TRANSISTOR 2SC2785-HFE	
C1011	1-102-121-00	CERAMIC	0.0022MF 10% 50V (KP-41T25/46S25/53S25)	Q234	8-729-119-78	TRANSISTOR 2SC2785-HFE	
C1012	1-102-121-00	CERAMIC	0.0022MF 10% 50V	Q235	8-729-119-76	TRANSISTOR 2SA1175-HFE	
		<CONNECTOR>		Q236	8-729-119-78	TRANSISTOR 2SC2785-HFE	
CN221	1-573-298-21	CONNECTOR, BOARD TO BOARD 20P		Q501	8-729-119-76	TRANSISTOR 2SA1175-HFE	
CN222	1-573-298-21	CONNECTOR, BOARD TO BOARD 20P		Q502	8-729-119-76	TRANSISTOR 2SA1175-HFE	
CN223	* 1-564-507-11	PLUG, CONNECTOR 4P		Q503	8-729-119-78	TRANSISTOR 2SC2785-HFE	
CN224	* 1-564-507-11	PLUG, CONNECTOR 4P		Q504	8-729-119-78	TRANSISTOR 2SC2785-HFE	
CN225	* 1-564-513-11	PLUG, CONNECTOR 10P		Q505	8-729-119-80	TRANSISTOR 2SC2688-LK	
CN511	* 1-580-689-11	PIN, CONNECTOR (PC BOARD) 4P		Q506	8-729-201-32	TRANSISTOR 2SA1013-O	
CN527	* 1-573-963-11	PIN, CONNECTOR (PC BOARD) 3P		Q507	8-729-304-92	TRANSISTOR 2SB649A-C	
CN528	1-695-915-11	TAB (CONTACT)		Q508	8-729-201-32	TRANSISTOR 2SA1013-O	
CN541	* 1-580-689-11	PIN, CONNECTOR (PC BOARD) 4P		Q509	8-729-010-98	TRANSISTOR 2SA1492M-OPY	
CN571	* 1-580-689-11	PIN, CONNECTOR (PC BOARD) 4P		Q510	8-729-021-48	TRANSISTOR 2SD2348LBSOBY	
CN1026	* 1-564-506-11	PLUG, CONNECTOR 3P		Q511	8-729-119-76	TRANSISTOR 2SA1175-HFE	
		<DIODE>		Q1001	8-729-119-76	TRANSISTOR 2SA1175-HFE (KP-41T25/46S25/53S25)	
D201	8-719-110-17	DIODE RD10ESB2		Q1002	8-729-119-76	TRANSISTOR 2SA1175-HFE (KP-41T25/46S25/53S25)	
D202	8-719-110-17	DIODE RD10ESB2		Q1003	8-729-119-76	TRANSISTOR 2SA1175-HFE	
D220	8-719-991-33	DIODE 1SS133T-77		Q1004	8-729-119-78	TRANSISTOR 2SC2785-HFE	
D221	8-719-991-33	DIODE 1SS133T-77					
D231	8-719-991-33	DIODE 1SS133T-77					



Les composants identifiés par une trame et une marque Δ sont critiques pour la sécurité. Ne les remplacer que par une pièce portant le numéro spécifié.

The components identified by shading and mark Δ are critical for safety. Replace only with part number specified.

REF. NO	PART NO	DESCRIPTION	REMARK
<RESISTOR>			
R201	1-249-429-11	CARBON 10K 5%	1/4W
R203	1-249-429-11	CARBON 10K 5%	1/4W
R204	1-249-429-11	CARBON 10K 5%	1/4W
R205	1-249-429-11	CARBON 10K 5%	1/4W
R207	1-249-431-11	CARBON 15K 5%	1/4W
R208	1-249-429-11	CARBON 10K 5%	1/4W
R209	1-249-431-11	CARBON 15K 5%	1/4W
R210	1-247-815-91	CARBON 220 5%	1/4W
R211	1-249-429-11	CARBON 10K 5%	1/4W
R212	1-249-441-11	CARBON 100K 5%	1/4W
R213	1-249-441-11	CARBON 100K 5%	1/4W
R214	1-247-815-91	CARBON 220 5%	1/4W
R215	1-249-441-11	CARBON 100K 5%	1/4W
R216	1-249-441-11	CARBON 100K 5%	1/4W
R217	1-247-807-31	CARBON 100 5%	1/4W
R218	1-247-807-31	CARBON 100 5%	1/4W
R219	1-249-417-11	CARBON 1K 5%	1/4W
R220	1-249-429-11	CARBON 10K 5%	1/4W
R221	1-249-437-11	CARBON 47K 5%	1/4W
R222	1-249-417-11	CARBON 1K 5%	1/4W
R223	1-249-429-11	CARBON 10K 5%	1/4W
R224	1-249-429-11	CARBON 10K 5%	1/4W
R230	1-249-430-11	CARBON 12K 5%	1/4W
R231	1-249-429-11	CARBON 10K 5%	1/4W
R233	1-249-429-11	CARBON 10K 5%	1/4W
R234	1-249-441-11	CARBON 100K 5%	1/4W
R235	1-249-414-11	CARBON 560 5%	1/4W
R236	1-249-432-11	CARBON 18K 5%	1/4W
R237	1-249-414-11	CARBON 560 5%	1/4W
R238	1-249-431-11	CARBON 15K 5%	1/4W
R239	1-249-430-11	CARBON 12K 5%	1/4W
R241	1-249-439-11	CARBON 68K 5%	1/4W
R242	1-249-432-11	CARBON 18K 5%	1/4W
R243	1-247-863-91	CARBON 22K 5%	1/4W
R244	1-247-863-91	CARBON 22K 5%	1/4W
R246	1-247-863-91	CARBON 22K 5%	1/4W
R247	1-249-430-11	CARBON 12K 5%	1/4W
R249	1-247-807-31	CARBON 100 5%	1/4W
R250	1-249-417-11	CARBON 1K 5%	1/4W
R251	1-249-437-11	CARBON 47K 5%	1/4W
R252	1-249-417-11	CARBON 1K 5%	1/4W
R255	1-249-429-11	CARBON 10K 5%	1/4W
R257	1-249-429-11	CARBON 10K 5%	1/4W
R258	1-249-429-11	CARBON 10K 5%	1/4W
R259	1-216-357-00	METAL OXIDE 4 7 5%	1W F
R260	1-216-357-00	METAL OXIDE 4 7 5%	1W F
R501	1-249-421-11	CARBON 2 2K 5%	1/4W
R502	1-249-429-11	CARBON 10K 5%	1/4W
R503	1-249-441-11	CARBON 100K 5%	1/4W
R504	1-249-429-11	CARBON 10K 5%	1/4W
R505	1-215-437-00	METAL 4 7K 1%	1/4W
R506	1-215-433-00	METAL 3 3K 1%	1/4W
R507	1-249-407-11	CARBON 150 5%	1/4W
R508	1-249-421-11	CARBON 2 2K 5%	1/4W
R509	1-249-423-11	CARBON 3 3K 5%	1/4W
R510	1-249-417-11	CARBON 1K 5%	1/4W
R511	1-247-895-91	CARBON 470K 5%	1/4W
R512	1-215-925-11	METAL OXIDE 22K 5%	3W F
R513	1-215-900-11	METAL OXIDE 22K 5%	2W F
R514	1-249-421-11	CARBON 2 2K 5%	1/4W F
R515	1-215-925-11	METAL OXIDE 22K 5%	3W F
R516	1-249-430-11	CARBON 12K 5%	1/4W F
R517	1-249-429-11	CARBON 10K 5%	1/4W
R518	1-249-427-11	CARBON 6 8K 5%	1/4W F
R519	1-249-417-11	CARBON 1K 5%	1/4W
R520	1-249-423-11	CARBON 3.3K 5%	1/4W F
R521	1-249-437-11	CARBON 47K 5%	1/4W

REF. NO.	PART NO	DESCRIPTION	REMARK
R522	1-249-417-11	CARBON 1K 5%	1/4W F
R523	1-249-426-11	CARBON 5 6K 5%	1/4W F
R524	1-215-925-11	METAL OXIDE 22K 5%	3W F
R525	1-216-373-11	METAL OXIDE 2 2 5%	2W F
R526	1-216-478-11	METAL OXIDE 390 5%	3W F
R528	1-216-475-11	METAL OXIDE 120 5%	3W F (KP-41T25)
R528	1-216-477-11	METAL OXIDE 270 5%	3W F (KP-46S1746S25/53S17/53S25)
R529	1-215-912-11	METAL OXIDE 150 5%	3W F (KP-41T25)
R529	1-216-477-11	METAL OXIDE 270 5%	3W F (KP-46S1746S25/53S17/53S25)
R530	1-216-475-11	METAL OXIDE 120 5%	3W F (KP-41T25)
R530	1-216-477-11	METAL OXIDE 270 5%	3W F (KP-46S1746S25/53S17/53S25)
R531	1-215-912-11	METAL OXIDE 150 5%	3W F (KP-41T25)
R531	1-216-477-11	METAL OXIDE 270 5%	3W F (KP-46S1746S25/53S17/53S25)
R532	1-215-442-00	METAL 7 5K 1%	1/4W
R533	1-215-443-00	METAL 8 2K 1%	1/4W
R534	1-215-437-00	METAL 4 7K 1%	1/4W
R1001	1-215-900-11	METAL OXIDE 22K 5%	2W F
R1002	1-215-900-11	METAL OXIDE 22K 5%	2W F (KP-41T25/46S25/53S25)
R1003	1-249-411-11	CARBON 330 5%	1/4W (KP-41T25/46S25/53S25)
R1004	1-249-434-11	CARBON 27K 5%	1/4W (KP-41T25/46S25/53S25)
R1005	1-249-436-11	CARBON 39K 5%	1/4W (KP-41T25/46S25/53S25)
R1006	1-249-434-11	CARBON 27K 5%	1/4W
R1007	1-249-425-11	CARBON 4 7K 5%	1/4W
R1008	1-247-807-31	CARBON 100 5%	1/4W (KP-46S1746S25/53S17/53S25)
R1010	1-249-411-11	CARBON 330 5%	1/4W
R1011	1-249-425-11	CARBON 4 7K 5%	1/4W (KP-41T25/46S25/53S25)
R1012	1-249-425-11	CARBON 4 7K 5%	1/4W (KP-41T25/46S25/53S25)
R1013	1-247-807-31	CARBON 100 5%	1/4W (KP-41T25/46S25/53S25)
R1014	1-249-436-11	CARBON 39K 5%	1/4W
R1016	1-247-807-31	CARBON 100 5%	1/4W
R1017	1-249-417-11	CARBON 1K 5%	1/4W
R1018	1-215-432-00	METAL 3K 1%	1/4W
R1019	1-249-441-11	CARBON 100K 5%	1/4W
<TRANSFORMER>			
T501	1-437-078-00	TRANSFORMER, HORIZONTAL DRIVE	
<TUNER>			
TU1001	Δ 8-598-047-11	TUNER (BTF-LA401)	(KP-41T25/46S25/53S25)
TU1002	Δ 8-598-254-00	TUNER (BTF-WA402)	



REF NO	PART NO	DESCRIPTION	REMARK	REF. NO	PART NO	DESCRIPTION	REMARK
	* A-1306-497-A	M BOARD, COMPLETE (KP-41T25) *****		C074	1-104-661-91	ELECT 330MF 20%	16V
	* A-1306-498-A	M BOARD, COMPLETE (KP-46S17/53S17) *****		C075	1-163-031-11	CERAMIC CHIP 0 01MF	50V
	* A-1306-530-A	M BOARD, COMPLETE (KP-46S25/53S25) *****		C302	1-124-902-00	ELECT 0 47MF 20%	50V
		<CAPACITOR>		C303	1-124-902-00	ELECT 0 47MF 20%	50V
C001	1-126-935-11	ELECT 470MF 20%	16V	C304	1-126-963-11	ELECT 4 7MF 20%	50V
C002	1-126-916-11	ELECT 1000MF 20%	6 3V	C309	1-163-019-00	CERAMIC CHIP 0 0068MF 10%	50V
C004	1-163-001-11	CERAMIC CHIP 220PF 10%	50V	C310	1-163-017-00	CERAMIC CHIP 0 0047MF 10%	50V
C005	1-163-001-11	CERAMIC CHIP 220PF 10%	50V	C311	1-124-925-11	ELECT 2 2MF 20%	50V
C006	1-163-001-11	CERAMIC CHIP 220PF 10%	50V	C312	1-163-017-00	CERAMIC CHIP 0 0047MF 10%	50V
C007	1-163-001-11	CERAMIC CHIP 220PF 10%	50V	C313	1-104-664-11	ELECT 47MF 20%	25V
C009	1-163-001-11	CERAMIC CHIP 220PF 10%	50V	C314	1-163-031-11	CERAMIC CHIP 0 01MF	50V
C010	1-163-001-11	CERAMIC CHIP 220PF 10%	50V	C315	1-126-934-11	ELECT 220MF 20%	16V
C011	1-163-001-11	CERAMIC CHIP 220PF 10%	50V	C316	1-131-374-00	TANTALUM 33MF 10%	16V
C012	1-163-001-11	CERAMIC CHIP 220PF 10%	50V	C317	1-163-031-11	CERAMIC CHIP 0 01MF	50V
C013	1-163-001-11	CERAMIC CHIP 220PF 10%	50V	C318	1-124-925-11	ELECT 2 2MF 20%	50V
C014	1-163-001-11	CERAMIC CHIP 220PF 10%	50V	C319	1-124-903-11	ELECT 1MF 20%	50V
C015	1-163-001-11	CERAMIC CHIP 220PF 10%	50V	C320	1-124-903-11	ELECT 1MF 20%	50V
C016	1-163-001-11	CERAMIC CHIP 220PF 10%	50V	C321	1-163-017-00	CERAMIC CHIP 0 0047MF 10%	50V
C017	1-163-001-11	CERAMIC CHIP 220PF 10%	50V	C322	1-163-031-11	CERAMIC CHIP 0 01MF	50V
C018	1-163-001-11	CERAMIC CHIP 220PF 10%	50V	C323	1-126-965-11	ELECT 22MF 20%	50V
C019	1-163-001-11	CERAMIC CHIP 220PF 10%	50V	C324	1-163-139-00	CERAMIC CHIP 820PF 5%	50V
C020	1-163-001-11	CERAMIC CHIP 220PF 10%	50V	C327	1-163-251-11	CERAMIC CHIP 100PF 5%	50V
C021	1-163-001-11	CERAMIC CHIP 220PF 10%	50V	C328	1-163-001-11	CERAMIC CHIP 220PF 10%	50V
C022	1-163-001-11	CERAMIC CHIP 220PF 10%	50V	C329	1-126-963-11	ELECT 4 7MF 20%	50V
C023	1-163-001-11	CERAMIC CHIP 220PF 10%	50V	C338	1-124-464-11	ELECT 0 22MF 20%	50V
C024	1-163-001-11	CERAMIC CHIP 220PF 10%	50V	C339	1-124-464-11	ELECT 0 22MF 20%	50V
C025	1-163-001-11	CERAMIC CHIP 220PF 10%	50V	C340	1-163-133-00	CERAMIC CHIP 470PF 5%	50V
C026	1-163-001-11	CERAMIC CHIP 220PF 10%	50V	C341	1-124-902-00	ELECT 0 47MF 20%	50V
C028	1-163-001-11	CERAMIC CHIP 220PF 10%	50V	C342	1-124-902-00	ELECT 0 47MF 20%	50V
C029	1-163-001-11	CERAMIC CHIP 220PF 10%	50V	C343	1-124-902-00	ELECT 0 47MF 20%	50V
C030	1-163-001-11	CERAMIC CHIP 220PF 10%	50V	C344	1-163-031-11	CERAMIC CHIP 0 01MF	50V
C031	1-163-001-11	CERAMIC CHIP 220PF 10%	50V	C345	1-163-031-11	CERAMIC CHIP 0 01MF	50V
C032	1-163-001-11	CERAMIC CHIP 220PF 10%	50V	C346	1-163-031-11	CERAMIC CHIP 0 01MF	50V
C033	1-163-809-11	CERAMIC CHIP 0 047MF 10%	25V	C347	1-124-902-00	ELECT 0 47MF 20%	50V
C034	1-163-001-11	CERAMIC CHIP 220PF 10%	50V	C348	1-163-231-11	CERAMIC CHIP 15PF 5%	50V
C035	1-124-903-11	ELECT 1MF 20%	50V	C349	1-163-243-11	CERAMIC CHIP 47PF 5%	50V
C037	1-163-009-11	CERAMIC CHIP 0 001MF 10%	50V	C350	1-126-964-11	ELECT 10MF 20%	50V
C038	1-104-661-91	ELECT 330MF 20%	16V				(KP-41T25)
C040	1-124-903-11	ELECT 1MF 20%	50V	C352	1-163-031-11	CERAMIC CHIP 0 01MF	50V
C041	1-163-001-11	CERAMIC CHIP 220PF 10%	50V	C353	1-104-665-11	ELECT 100MF 20%	25V
C042	1-163-001-11	CERAMIC CHIP 220PF 10%	50V	C354	1-163-235-11	CERAMIC CHIP 22PF 5%	50V
C046	1-163-125-00	CERAMIC CHIP 220PF 5%	50V	C355	1-126-965-11	ELECT 22MF 20%	50V
C047	1-124-903-11	ELECT 1MF 20%	50V				(KP-41T25)
C048	1-163-245-11	CERAMIC CHIP 56PF 5%	50V	C357	1-104-664-11	ELECT 47MF 20%	25V
C049	1-163-001-11	CERAMIC CHIP 220PF 10%	50V				(KP-41T25)
C050	1-163-031-11	CERAMIC CHIP 0 01MF	50V	C358	1-163-231-11	CERAMIC CHIP 15PF 5%	50V
C051	1-163-017-00	CERAMIC CHIP 0 0047MF 10%	50V				(KP-41T25)
C054	1-163-001-11	CERAMIC CHIP 220PF 10%	50V	C359	1-163-125-00	CERAMIC CHIP 220PF 5%	50V
C055	1-163-037-11	CERAMIC CHIP 0 022MF 10%	50V	C360	1-126-964-11	ELECT 10MF 20%	50V
C056	1-163-001-11	CERAMIC CHIP 220PF 10%	50V				(KP-41T25)
C057	1-163-229-11	CERAMIC CHIP 12PF 5%	50V	C361	1-126-964-11	ELECT 10MF 20%	50V
C058	1-163-102-00	CERAMIC CHIP 24PF 5%	50V				(KP-41T25)
C060	1-124-903-11	ELECT 1MF 20%	50V	C362	1-163-235-11	CERAMIC CHIP 22PF 5%	50V
C062	1-163-038-91	CERAMIC CHIP 0 1MF	25V				(KP-41T25)
C063	1-126-964-11	ELECT 10MF 20%	50V	C363	1-163-009-11	CERAMIC CHIP 0 001MF 10%	50V
C064	1-126-964-11	ELECT 10MF 20%	50V				(KP-41T25)
C065	1-163-038-91	CERAMIC CHIP 0 1MF	25V	C364	1-126-964-11	ELECT 10MF 20%	50V
C066	1-163-135-00	CERAMIC CHIP 560PF 5%	50V				(KP-41T25)
C067	1-137-399-11	FILM 0 1MF 5%	50V	C365	1-163-235-11	CERAMIC CHIP 22PF 5%	50V
C068	1-137-367-11	FILM 0 0033MF 5%	50V				(KP-41T25)
C069	1-137-375-11	FILM 0 068MF 5%	50V	C366	1-163-251-11	CERAMIC CHIP 100PF 5%	50V
C070	1-104-664-11	ELECT 47MF 20%	25V	C368	1-163-227-11	CERAMIC CHIP 10PF 0 5PF	50V
C071	1-124-464-11	ELECT 0 22MF 20%	50V	C369	1-163-809-11	CERAMIC CHIP 0 047MF 10%	25V
				C370	1-104-665-11	ELECT 100MF 20%	25V
				C371	1-104-665-11	ELECT 100MF 20%	25V
							<CHIP CONDUCTOR>
				CJ001	1-216-295-91	CONDUCTOR, CHIP	



REF. NO	PART NO	DESCRIPTION	REMARK	REF NO	PART NO	DESCRIPTION	REMARK
CJ002	1-216-295-91	CONDUCTOR, CHIP		IC004	8-759-328-12	IC Z8622812PSC	
CJ003	1-216-295-91	CONDUCTOR, CHIP		IC005	8-759-370-31	IC ST24C01FB6	
		<CONNECTOR>		IC006	8-759-403-44	IC MN1280-S	
CN046	* 1-564-512-11	PLUG, CONNECTOR 9P		IC301	8-752-063-50	IC CXA1477AS	
CN052	* 1-564-507-11	PLUG, CONNECTOR 4P		IC302	8-759-231-53	IC TA7805S	
		(KP-41T25/46S25/53S25)				<COIL>	
CN053	* 1-564-507-11	PLUG, CONNECTOR 4P		L003	1-410-470-11	INDUCTOR 10UH	
CN054	1-573-979-21	CONNECTOR, BOARD TO BOARD 11P		L004	1-410-476-11	INDUCTOR 33UH	
CN304	* 1-564-512-11	PLUG, CONNECTOR 9P		L005	1-410-470-11	INDUCTOR 10UH	
CN314	* 1-564-509-11	PLUG, CONNECTOR 6P (KP-41T25)		L006	1-410-470-11	INDUCTOR 10UH	
CN321	1-573-301-21	CONNECTOR, BOARD TO BOARD 20P		L302	1-408-413-00	INDUCTOR 22UH (KP-41T25)	
CN322	1-573-301-21	CONNECTOR, BOARD TO BOARD 20P		L303	1-408-416-00	INDUCTOR 39UH (KP-41T25)	
CN351	* 1-564-509-11	PLUG, CONNECTOR 6P		L304	1-410-468-11	INDUCTOR 6 8UH	
CN355	* 1-565-930-11	CONNECTOR (RECEPTACLE) 30P				<TRANSISTOR>	
CN356	* 1-566-367-11	CONNECTOR, HINGE (RECEPTACLE)		Q001	8-729-216-22	TRANSISTOR 2SA1162-G	
CN357	* 1-564-516-11	PLUG, CONNECTOR 13P		Q002	8-729-422-27	TRANSISTOR 2SD601A-Q	
CN358	* 1-564-508-11	PLUG, CONNECTOR 5P		Q003	8-729-422-27	TRANSISTOR 2SD601A-Q	
		<DIODE>		Q004	8-729-216-22	TRANSISTOR 2SA1162-G	
D001	8-719-404-46	DIODE MA110		Q005	8-729-422-27	TRANSISTOR 2SD601A-Q	
D002	8-719-404-46	DIODE MA110		Q006	8-729-422-27	TRANSISTOR 2SD601A-Q	
D003	8-719-404-46	DIODE MA110		Q007	8-729-216-22	TRANSISTOR 2SA1162-G	
D004	8-719-109-89	DIODE RD5 6ESB2		Q008	8-729-216-22	TRANSISTOR 2SA1162-G	
D005	8-719-109-89	DIODE RD5 6ESB2		Q009	8-729-422-27	TRANSISTOR 2SD601A-Q	
D006	8-719-109-89	DIODE RD5 6ESB2		Q010	8-729-216-22	TRANSISTOR 2SA1162-G	
D007	8-719-109-89	DIODE RD5 6ESB2		Q011	8-729-216-22	TRANSISTOR 2SA1162-G	
D008	8-719-002-81	DIODE 1T363		Q012	8-729-422-27	TRANSISTOR 2SD601A-Q	
D009	8-719-404-46	DIODE MA110		Q013	8-729-216-22	TRANSISTOR 2SA1162-G	(KP-41T25/46S25/53S25)
D010	8-719-404-46	DIODE MA110		Q014	8-729-216-22	TRANSISTOR 2SA1162-G	(KP-41T25/46S25/53S25)
D011	8-719-404-46	DIODE MA110		Q015	8-729-422-27	TRANSISTOR 2SD601A-Q	(KP-41T25/46S25/53S25)
D012	8-719-404-46	DIODE MA110		Q016	8-729-216-22	TRANSISTOR 2SA1162-G	(KP-41T25/46S25/53S25)
D013	8-719-404-46	DIODE MA110		Q017	8-729-422-27	TRANSISTOR 2SD601A-Q	
D014	8-719-404-46	DIODE MA110		Q018	8-729-216-22	TRANSISTOR 2SA1162-G	
D015	8-719-404-46	DIODE MA110		Q019	8-729-422-27	TRANSISTOR 2SD601A-Q	
D016	8-719-404-46	DIODE MA110		Q301	8-729-216-22	TRANSISTOR 2SA1162-G	
D017	8-719-404-46	DIODE MA110		Q302	8-729-216-22	TRANSISTOR 2SA1162-G	
D018	8-719-404-46	DIODE MA110		Q303	8-729-216-22	TRANSISTOR 2SA1162-G	
D019	8-719-404-46	DIODE MA110		Q304	8-729-216-22	TRANSISTOR 2SA1162-G	
D020	8-719-105-91	DIODE RD5 6M-B2		Q305	8-729-422-27	TRANSISTOR 2SD601A-Q	
D305	8-719-923-60	DIODE MTZJ-T-77-9 1A		Q307	8-729-422-27	TRANSISTOR 2SD601A-Q	
D307	8-719-923-60	DIODE MTZJ-T-77-9 1A		Q308	8-729-216-22	TRANSISTOR 2SA1162-G	
D308	8-719-110-22	DIODE RD1 1ESB2		Q309	8-729-216-22	TRANSISTOR 2SA1162-G	
D309	8-719-109-84	DIODE RD5 1ESB1		Q310	8-729-422-27	TRANSISTOR 2SD601A-Q (KP-41T25)	
D310	8-719-914-44	DIODE DAP202K		Q311	8-729-422-27	TRANSISTOR 2SD601A-Q	
D311	8-719-914-43	DIODE DAN202K		Q312	8-729-422-27	TRANSISTOR 2SD601A-Q (KP-41T25)	
D312	8-719-404-46	DIODE MA110		Q313	8-729-422-27	TRANSISTOR 2SD601A-Q	
D313	8-719-404-46	DIODE MA110		Q314	8-729-422-27	TRANSISTOR 2SD601A-Q (KP-41T25)	
D314	8-719-404-46	DIODE MA110		Q315	8-729-422-27	TRANSISTOR 2SD601A-Q (KP-41T25)	
D315	8-719-109-89	DIODE RD5 6ESB2		Q316	8-729-422-27	TRANSISTOR 2SD601A-Q (KP-41T25)	
D316	8-719-404-46	DIODE MA110		Q317	8-729-216-22	TRANSISTOR 2SA1162-G (KP-41T25)	
D317	8-719-110-22	DIODE RD1 1ESB2		Q318	8-729-422-27	TRANSISTOR 2SD601A-Q (KP-41T25)	
D320	8-719-404-46	DIODE MA110 (KP-41T25)		Q319	8-729-422-27	TRANSISTOR 2SD601A-Q (KP-41T25)	
D321	8-719-404-46	DIODE MA110 (KP-41T25)		Q320	8-729-422-27	TRANSISTOR 2SD601A-Q (KP-41T25)	
D322	8-719-404-46	DIODE MA110 (KP-41T25)		Q321	8-729-422-27	TRANSISTOR 2SD601A-Q (KP-41T25)	
D323	8-719-404-46	DIODE MA110 (KP-41T25)		Q322	8-729-422-27	TRANSISTOR 2SD601A-Q	
D324	8-719-404-46	DIODE MA110 (KP-41T25)				<RESISTOR>	
D325	8-719-404-46	DIODE MA110 (KP-41T25)		R001	1-216-049-91	METAL GLAZE 1K	5% 1/10W
D326	8-719-110-08	DIODE RD8 2ESB2		R002	1-216-049-91	METAL GLAZE 1K	5% 1/10W
D327	8-719-404-46	DIODE MA110		R003	1-216-033-00	METAL GLAZE 220	5% 1/10W
D328	8-719-991-33	DIODE 1SS133T-77		R004	1-216-033-00	METAL GLAZE 220	5% 1/10W
		<IC>		R005	1-216-033-00	METAL GLAZE 220	5% 1/10W
IC001	8-759-112-06	IC uPC78N05H					
IC002	8-752-859-03	IC CXP85332A-056S					
IC003	8-759-370-33	IC ST24C04FB6					



REF. NO	PART NO	DESCRIPTION	REMARK	REF. NO	PART NO	DESCRIPTION	REMARK
R006	1-216-033-00	METAL GLAZE 220	5%	R075	1-216-069-00	METAL GLAZE 6 8K	5%
R007	1-216-033-00	METAL GLAZE 220	5%	R076	1-216-089-91	METAL GLAZE 47K	5%
R008	1-216-033-00	METAL GLAZE 220	5%	R077	1-216-097-91	METAL GLAZE 100K	5%
R009	1-216-033-00	METAL GLAZE 220	5%	R078	1-216-097-91	METAL GLAZE 100K	5%
R010	1-216-073-00	METAL GLAZE 10K	5%	R079	1-216-081-00	METAL GLAZE 22K	5%
R011	1-216-033-00	METAL GLAZE 220	5%	R080	1-216-023-00	METAL GLAZE 82	5%
R012	1-216-033-00	METAL GLAZE 220	5%	R081	1-216-041-00	METAL GLAZE 470	5%
R013	1-216-073-00	METAL GLAZE 10K	5%	R082	1-216-093-00	METAL GLAZE 68K	5%
R014	1-216-073-00	METAL GLAZE 10K	5%	R083	1-216-065-00	METAL GLAZE 4 7K	5%
R015	1-216-033-00	METAL GLAZE 220	5%	R084	1-216-073-00	METAL GLAZE 10K	5%
R016	1-216-033-00	METAL GLAZE 220	5%	R085	1-216-089-91	METAL GLAZE 47K	5%
R017	1-216-073-00	METAL GLAZE 10K	5%	R086	1-216-097-91	METAL GLAZE 100K	5%
R018	1-216-049-91	METAL GLAZE 1K	5%	R087	1-216-073-00	METAL GLAZE 10K	5%
R019	1-216-033-00	METAL GLAZE 220	5%	R088	1-216-089-91	METAL GLAZE 47K	5%
R020	1-216-033-00	METAL GLAZE 220	5%	R089	1-216-065-00	METAL GLAZE 4.7K	5%
R021	1-216-033-00	METAL GLAZE 220	5%	R090	1-216-073-00	METAL GLAZE 10K	5%
R022	1-216-097-91	METAL GLAZE 100K	5%	R091	1-216-081-00	METAL GLAZE 22K	5%
R023	1-216-121-91	METAL GLAZE 1M	5%	R092	1-216-081-00	METAL GLAZE 22K	5%
R024	1-216-065-00	METAL GLAZE 4 7K	5%	R093	1-216-295-91	CONDUCTOR, CHIP	5%
R025	1-216-073-00	METAL GLAZE 10K	5%	R094	1-216-081-00	METAL GLAZE 22K	5%
R026	1-216-073-00	METAL GLAZE 10K	5%	R095	1-216-081-00	METAL GLAZE 22K	5%
R027	1-216-089-91	METAL GLAZE 47K	5%	R096	1-216-081-00	METAL GLAZE 22K	5%
R028	1-216-065-00	METAL GLAZE 4 7K	5%	R097	1-216-081-00	METAL GLAZE 22K	5%
R029	1-216-065-00	METAL GLAZE 4 7K	5%	R098	1-216-081-00	METAL GLAZE 22K	5%
R030	1-216-065-00	METAL GLAZE 4 7K	5%	R099	1-216-081-00	METAL GLAZE 22K	5%
R031	1-216-065-00	METAL GLAZE 4 7K	5%	R100	1-216-295-91	CONDUCTOR, CHIP	5%
R032	1-216-065-00	METAL GLAZE 4 7K	5%	R101	1-216-065-00	METAL GLAZE 4.7K	5%
R033	1-216-065-00	METAL GLAZE 4.7K	5%	R102	1-216-089-91	METAL GLAZE 47K	5%
R034	1-216-073-00	METAL GLAZE 10K	5%	R103	1-216-045-00	METAL GLAZE 680	5%
R035	1-216-033-00	METAL GLAZE 220	5%	R104	1-216-033-00	METAL GLAZE 220	5%
R036	1-216-025-91	METAL GLAZE 100	5%	R106	1-216-033-00	METAL GLAZE 220	5%
R037	1-216-033-00	METAL GLAZE 220	5%	R107	1-216-033-00	METAL GLAZE 220	5%
R038	1-216-033-00	METAL GLAZE 220	5%	R108	1-216-033-00	METAL GLAZE 220	5%
R039	1-216-025-91	METAL GLAZE 100	5%	R109	1-216-033-00	METAL GLAZE 220	5%
R040	1-216-033-00	METAL GLAZE 220	5%	R110	1-216-033-00	METAL GLAZE 220	5%
R041	1-216-033-00	METAL GLAZE 220	5%	R111	1-216-049-91	METAL GLAZE 1K	5%
R042	1-216-033-00	METAL GLAZE 220	5%	R112	1-216-089-91	METAL GLAZE 47K	5%
R043	1-216-073-00	METAL GLAZE 10K	5%	R113	1-216-089-91	METAL GLAZE 47K	5%
R044	1-216-089-91	METAL GLAZE 47K	5%	R114	1-216-065-00	METAL GLAZE 4 7K	5%
R045	1-216-033-00	METAL GLAZE 220	5%	R115	1-216-065-00	METAL GLAZE 4 7K	5%
R046	1-216-033-00	METAL GLAZE 220	5%	R116	1-216-065-00	METAL GLAZE 4 7K	5%
R047	1-216-033-00	METAL GLAZE 220	5%	R117	1-216-047-91	METAL GLAZE 820	5%
R048	1-216-073-00	METAL GLAZE 10K	5%	R118	1-216-047-91	METAL GLAZE 820	5%
R049	1-216-033-00	METAL GLAZE 220	5%	R119	1-216-047-91	METAL GLAZE 820	5%
R050	1-216-049-91	METAL GLAZE 1K	5%	R120	1-216-033-00	METAL GLAZE 220	5%
R051	1-216-049-91	METAL GLAZE 1K	5%	R300	1-216-025-91	METAL GLAZE 100	5%
R052	1-216-065-00	METAL GLAZE 4 7K	5%	R301	1-216-059-00	METAL GLAZE 2 7K	5%
R054	1-216-073-00	METAL GLAZE 10K	5%	R302	1-216-049-91	METAL GLAZE 1K	5%
R055	1-216-049-91	METAL GLAZE 1K	5%	R303	1-216-049-91	METAL GLAZE 1K	5%
R056	1-216-049-91	METAL GLAZE 1K	5%	R304	1-216-049-91	METAL GLAZE 1K	5%
R057	1-216-065-00	METAL GLAZE 4.7K	5%	R305	1-216-025-91	METAL GLAZE 100	5%
R058	1-216-073-00	METAL GLAZE 10K	5%	R306	1-216-025-91	METAL GLAZE 100	5%
R059	1-216-295-91	CONDUCTOR, CHIP	5%	R307	1-216-057-00	METAL GLAZE 2 2K	5%
R060	1-216-065-00	METAL GLAZE 4 7K	5%	R308	1-216-073-00	METAL GLAZE 10K	5%
R061	1-216-033-00	METAL GLAZE 220	5%	R309	1-216-025-91	METAL GLAZE 220	5%
R062	1-216-085-00	METAL GLAZE 33K	5%	R310	1-216-081-00	METAL GLAZE 22K	5%
R063	1-216-041-00	METAL GLAZE 470	5%	R311	1-216-025-91	METAL GLAZE 100	5%
R064	1-216-065-00	METAL GLAZE 4 7K	5%	R312	1-216-033-00	METAL GLAZE 220	5%
R065	1-216-097-91	METAL GLAZE 100K	5%	R313	1-216-081-00	METAL GLAZE 22K	5%
R066	1-216-049-91	METAL GLAZE 1K	5%	R314	1-216-033-00	METAL GLAZE 220	5%
R067	1-216-049-91	METAL GLAZE 1K	5%	R315	1-216-067-00	METAL GLAZE 5 6K	5%
R068	1-216-049-91	METAL GLAZE 1K	5%	R317	1-216-033-00	METAL GLAZE 220	5%
R069	1-216-073-00	METAL GLAZE 10K	5%				
R070	1-216-073-00	METAL GLAZE 10K	5%				
R071	1-216-073-00	METAL GLAZE 10K	5%				
R072	1-216-041-00	METAL GLAZE 470	5%				
R073	1-216-049-91	METAL GLAZE 1K	5%				
R074	1-216-049-91	METAL GLAZE 1K	5%				



Les composants identifiés par une trame et une marque Δ sont critiques pour la sécurité. Ne les remplacer que par une pièce portant le numéro spécifique.

The components identified by shading and mark Δ are critical for safety. Replace only with part number specified.

REF NO.	PART NO	DESCRIPTION	REMARK
R318	1-216-071-00	METAL GLAZE 8 2K	5% 1/10W
R319	1-216-190-00	METAL GLAZE 470	5% 1/8W
R320	1-216-065-00	METAL GLAZE 4 7K	5% 1/10W
R321	1-216-190-00	METAL GLAZE 470	5% 1/8W
R323	1-216-295-91	CONDUCTOR, CHIP	
R324	1-216-025-91	METAL GLAZE 100	5% 1/10W
R325	1-216-043-91	METAL GLAZE 560	5% 1/10W
R326	1-216-077-00	METAL GLAZE 15K	5% 1/10W
R327	1-216-033-00	METAL GLAZE 220	5% 1/10W
R328	1-216-025-91	METAL GLAZE 100	5% 1/10W
R329	1-216-085-00	METAL GLAZE 33K	5% 1/10W
R330	1-216-039-00	METAL GLAZE 390	5% 1/10W
R331	1-216-059-00	METAL GLAZE 2 7K	5% 1/10W
R332	1-216-049-91	METAL GLAZE 1K	5% 1/10W
R333	1-208-810-11	METAL CHIP 15K	0 50% 1/10W
R335	1-216-033-00	METAL GLAZE 220	5% 1/10W
R336	1-216-033-00	METAL GLAZE 220	5% 1/10W
R337	1-216-049-91	METAL GLAZE 1K	5% 1/10W
R338	1-216-049-91	METAL GLAZE 1K	5% 1/10W
R339	1-216-655-11	METAL CHIP 1 5K	0 50% 1/10W
R340	1-216-033-00	METAL GLAZE 220	5% 1/10W
R341	1-216-033-00	METAL GLAZE 220	5% 1/10W
R342	1-216-033-00	METAL GLAZE 220	5% 1/10W
R343	1-216-077-00	METAL GLAZE 15K	5% 1/10W
R344	1-216-073-00	METAL GLAZE 10K	5% 1/10W
R345	1-216-025-91	METAL GLAZE 100	5% 1/10W
R346	1-216-037-00	METAL GLAZE 330	5% 1/10W
R347	1-216-041-00	METAL GLAZE 470	5% 1/10W
R348	1-216-049-91	METAL GLAZE 1K	5% 1/10W (KP-41T25)
R349	1-216-033-00	METAL GLAZE 220	5% 1/10W
R350	1-216-033-00	METAL GLAZE 220	5% 1/10W
R351	1-216-033-00	METAL GLAZE 220	5% 1/10W
R352	1-216-057-00	METAL GLAZE 2 2K	5% 1/10W (KP-41T25)
R353	1-216-069-00	METAL GLAZE 6 8K	5% 1/10W (KP-41T25)
R354	1-216-053-00	METAL GLAZE 1 5K	5% 1/10W
R355	1-216-071-00	METAL GLAZE 8 2K	5% 1/10W
R356	1-216-031-00	METAL GLAZE 180	5% 1/10W (KP-41T25)
R357	1-216-031-00	METAL GLAZE 180	5% 1/10W (KP-41T25)
R358	1-216-049-91	METAL GLAZE 1K	5% 1/10W
R359	1-216-037-00	METAL GLAZE 330	5% 1/10W (KP-41T25)
R360	1-216-035-00	METAL GLAZE 270	5% 1/10W
R361	1-216-049-91	METAL GLAZE 1K	5% 1/10W
R362	1-216-035-00	METAL GLAZE 270	5% 1/10W (KP-41T25)
R363	1-216-049-91	METAL GLAZE 1K	5% 1/10W (KP-41T25)
R364	1-216-025-91	METAL GLAZE 100	5% 1/10W
R366	1-216-053-00	METAL GLAZE 1 5K	5% 1/10W (KP-41T25)
R367	1-216-057-00	METAL GLAZE 2 2K	5% 1/10W (KP-41T25)
R368	1-216-025-91	METAL GLAZE 100	5% 1/10W (KP-41T25)
R369	1-216-061-00	METAL GLAZE 3 3K	5% 1/10W (KP-41T25)
R370	1-216-033-00	METAL GLAZE 220	5% 1/10W
R371	1-216-049-91	METAL GLAZE 1K	5% 1/10W (KP-41T25)
R372	1-216-051-00	METAL GLAZE 1 2K	5% 1/10W (KP-41T25)
R373	1-216-035-00	METAL GLAZE 270	5% 1/10W (KP-41T25)
R374	1-216-085-00	METAL GLAZE 33K	5% 1/10W (KP-41T25)

REF. NO	PART NO	DESCRIPTION	REMARK
R375	1-216-075-00	METAL GLAZE 12K	5% 1/10W (KP-41T25)
R376	1-216-093-00	METAL GLAZE 68K	5% 1/10W (KP-41T25)
R377	1-216-043-91	METAL GLAZE 560	5% 1/10W (KP-41T25)
R378	1-216-059-00	METAL GLAZE 2 7K	5% 1/10W (KP-41T25)
R379	1-216-083-00	METAL GLAZE 27K	5% 1/10W (KP-41T25)
R380	1-216-097-91	METAL GLAZE 100K	5% 1/10W (KP-41T25)
R381	1-216-071-00	METAL GLAZE 8 2K	5% 1/10W (KP-41T25)
R382	1-216-085-00	METAL GLAZE 33K	5% 1/10W (KP-41T25)
R383	1-216-043-91	METAL GLAZE 560	5% 1/10W (KP-41T25)
R384	1-216-053-00	METAL GLAZE 1 5K	5% 1/10W (KP-41T25)
R385	1-216-085-00	METAL GLAZE 33K	5% 1/10W (KP-41T25)
R386	1-216-121-91	METAL GLAZE 1M	5% 1/10W (KP-41T25)
R387	1-216-049-91	METAL GLAZE 1K	5% 1/10W (KP-41T25)
R388	1-216-025-91	METAL GLAZE 100	5% 1/10W (KP-41T25)
R389	1-216-033-00	METAL GLAZE 220	5% 1/10W (KP-41T25)
R390	1-216-033-00	METAL GLAZE 220	5% 1/10W
R391	1-216-061-00	METAL GLAZE 3 3K	5% 1/10W
R392	1-216-059-00	METAL GLAZE 2 7K	5% 1/10W
R393	1-216-049-91	METAL GLAZE 1K	5% 1/10W (KP-41T25)
R394	1-216-295-91	CONDUCTOR, CHIP	
<CRYSTAL>			
X001	1-579-917-11	VIBRATOR, CRYSTAL	
X301	1-577-611-11	OSCILLATOR, CERAMIC	
X302	1-567-505-11	OSCILLATOR, CRYSTAL	

* A-1316-212-A G BOARD, COMPLETE *****			
* 4-047-936-01 PLATE, SHIELD, PIT			
<CAPACITOR>			
C601	Δ 1-136-311-51	FILM	0.47MF 20% 125V
C602	Δ 1-113-920-91	ELECT	0.0022MF 20% 250V
C603	Δ 1-113-920-91	ELECT	0.0022MF 20% 250V
C604	Δ 1-125-692-11	ELECT(BLOCK)	820MF 20% 200V
C605	Δ 1-125-692-11	ELECT(BLOCK)	820MF 20% 200V
C608	1-164-645-11	CERAMIC	1000PF 10% 500V
C609	1-164-645-11	CERAMIC	1000PF 10% 500V
C610	1-136-173-00	FILM	0.47MF 5% 50V
C611	1-136-171-00	FILM	0.33MF 5% 50V
C612	1-136-173-00	FILM	0.47MF 5% 50V
C613	1-136-171-00	FILM	0.33MF 5% 50V
C614	1-164-735-11	CAPACITOR	0.0015MF 10% 500V
C615	1-129-720-00	FILM	0.033MF 5% 630V
C616	Δ 1-136-311-51	FILM	0.47MF 20% 125V
C618	Δ 1-113-910-91	ELECT	470PF 10% 250V
C619	Δ 1-113-910-91	ELECT	470PF 10% 250V
C651	1-128-548-11	ELECT	4700MF 20% 25V
C652	1-128-548-11	ELECT	4700MF 20% 25V
C653	1-162-318-11	CERAMIC	0.001MF 10% 500V

The components identified by shading and mark Δ are critical for safety
Replace only with part number specified

Les composants identifiés par une trame et une marque Δ sont critiques pour la sécurité
Ne les remplacer que par une pièce portant le numéro spécifique



REF. NO.	PART NO	DESCRIPTION	REMARK	REF NO	PART NO	DESCRIPTION	REMARK
C656	1-128-548-11	ELECT	4700MF 20% 25V	D671	8-719-991-33	DIODE 1SS133T-77	
C657	1-126-926-11	ELECT	1000MF 20% 10V	D672	8-719-109-54	DIODE RD2 2ESB2	
C658	1-126-768-11	ELECT	2200MF 20% 16V	D673	8-719-110-49	DIODE RD18ESB2	
C659	1-126-944-11	ELECT	3300MF 20% 25V	D674	8-719-991-33	DIODE 1SS133T-77	
C660	1-164-644-11	CERAMIC	330PF 10% 500V	D675	8-719-109-85	DIODE RD5 1ESB2	
C661	1-123-024-21	ELECT	33MF 160V	D676	8-719-991-33	DIODE 1SS133T-77	
C662	1-107-636-11	ELECT	10MF 20% 160V	D677	8-719-991-33	DIODE 1SS133T-77	
C663	1-126-948-11	ELECT	100MF 20% 35V	D678	8-719-991-33	DIODE 1SS133T-77	
C664	1-126-235-11	ELECT	100MF 20% 6 3V	D679	8-719-991-33	DIODE 1SS133T-77	
C665	1-126-964-11	ELECT	10MF 20% 50V	D680	8-719-200-82	DIODE 11ES2	
C667	1-126-951-11	ELECT	470MF 20% 35V	D681	8-719-200-82	DIODE 11ES2	
C668	1-104-664-11	ELECT	47MF 20% 25V	D682	8-719-200-82	DIODE 11ES2	
C669	1-162-318-11	CERAMIC	0 001MF 10% 500V	D683	8-719-200-82	DIODE 11ES2	
C670	1-104-664-11	ELECT	47MF 20% 25V	D685	8-719-991-33	DIODE 1SS133T-77	
C671	1-104-664-11	ELECT	47MF 20% 25V	D686	8-719-991-33	DIODE 1SS133T-77	
C672	1-104-665-11	ELECT	100MF 20% 25V	D687	8-719-109-85	DIODE RD5 1ESB2	
C673	1-104-664-11	ELECT	47MF 20% 25V	D688	8-719-991-33	DIODE 1SS133T-77	
C674	1-104-664-11	ELECT	47MF 20% 25V	D689	8-719-991-33	DIODE 1SS133T-77	
C675	1-104-664-11	ELECT	47MF 20% 25V	D690	8-719-109-89	DIODE RD5 6ESB2	
C676	1-104-664-11	ELECT	47MF 20% 25V	D691	8-719-991-33	DIODE 1SS133T-77	
C677	1-125-473-11	ELECT(BLOCK)	1000MF 20% 160V	D693	8-719-991-33	DIODE 1SS133T-77	
C678	1-107-635-11	ELECT	4 7MF 20% 160V			<FUSE>	
C679	1-164-644-11	CERAMIC	330PF 10% 500V				
C680	1-124-903-11	ELECT	1MF 20% 50V				
C682	1-124-903-11	ELECT	1MF 20% 50V	F601	Δ 1-576-193-11	FUSE 6.3A/125V	
C683	1-107-635-11	ELECT	4 7MF 20% 160V		1-533-223-11	CLIP, FUSE ; F601	
C690	1-126-934-11	ELECT	220MF 20% 16V			<FERRITE BEAD>	
C691	1-126-964-11	ELECT	10MF 20% 50V				
		<CONNECTOR>					
CN606	1-695-915-11	TAB (CONTACT)					
CN615	1-695-915-11	TAB (CONTACT)					
CN616	* 1-564-507-11	PLUG, CONNECTOR 4P					<IC>
CN617	* 1-580-843-11	PIN, CONNECTOR (POWER)					
CN624	* 1-564-507-11	PLUG, CONNECTOR 4P		IC651	Δ 1-810-051-21	POWER MODULE (DM-48)	
CN625	* 1-564-513-11	PLUG, CONNECTOR 10P		IC652	8-759-279-76	IC MCT7812CT	
CN626	* 1-564-506-11	PLUG, CONNECTOR 3P				<COIL>	
CN653	* 1-564-507-11	PLUG, CONNECTOR 4P					
CN681	* 1-573-986-11	PIN, CONNECTOR (PC BOARD) 5P		L651	1-403-588-11	CIL, CHOKE 22UH	
		<DIODE>		L652	1-403-588-11	CIL, CHOKE 22UH	
D601	Δ 8-719-052-29	DIODE LN4SB60-F		L653	1-412-519-11	INDUCTOR 3 3UH	
D604	8-719-991-33	DIODE 1SS133T-77		L654	1-403-588-11	CIL, CHOKE 22UH	
D605	8-719-991-33	DIODE 1SS133T-77		L655	1-403-588-11	CIL, CHOKE 22UH	
D606	8-719-991-33	DIODE 1SS133T-77		L656	1-412-519-11	INDUCTOR 3 3UH	
D607	8-719-991-33	DIODE 1SS133T-77		L657	1-403-588-11	CIL, CHOKE 22UH	
D608	8-719-991-33	DIODE 1SS133T-77		L658	1-403-588-11	CIL, CHOKE 22UH	
D609	8-719-991-33	DIODE 1SS133T-77				<TRANSISTOR>	
D610	8-719-991-33	DIODE 1SS133T-77		Q601	8-729-019-49	TRANSISTOR 2SC4834M	
D611	8-719-991-33	DIODE 1SS133T-77		Q602	8-729-019-49	TRANSISTOR 2SC4834M	
D651	8-719-052-91	DIODE D4SBS4-F		Q651	8-729-820-82	TRANSISTOR 2SA1208-S	
D655	8-719-052-92	DIODE D10SBS4F		Q652	8-729-119-76	TRANSISTOR 2SA1175-HFE	
D656	8-719-022-97	DIODE D2S4MF		Q653	8-729-230-45	TRANSISTOR 2SC2458-YGR	
D657	8-719-022-97	DIODE D2S4MF		Q654	8-729-119-76	TRANSISTOR 2SA1175-HFE	
D658	8-719-022-97	DIODE D2S4MF		Q655	8-729-230-45	TRANSISTOR 2SC2458-YGR	
D659	8-719-022-97	DIODE D2S4MF		Q656	8-729-119-76	TRANSISTOR 2SA1175-HFE	
D660	8-719-052-86	DIODE D2L40-TA		Q657	8-729-119-78	TRANSISTOR 2SC2785-HFE	
D661	8-719-052-86	DIODE D2L40-TA		Q658	8-729-119-76	TRANSISTOR 2SA1175-HFE	
D662	8-719-052-31	DIODE D1NL40-TR2		Q659	8-729-119-76	TRANSISTOR 2SA1175-HFE	
D663	8-719-052-31	DIODE D1NL40-TR2		Q660	8-729-119-76	TRANSISTOR 2SA1175-HFE	
D664	8-719-510-26	DIODE D1NL20-TA		Q661	8-729-119-76	TRANSISTOR 2SA1175-HFE	
D665	8-719-991-33	DIODE 1SS133T-77		Q662	8-729-119-76	TRANSISTOR 2SA1175-HFE	
D666	8-719-110-58	DIODE RD22ESB3		Q663	8-729-119-76	TRANSISTOR 2SA1175-HFE	
D667	8-719-921-80	DIODE MTZJ-11B				<RESISTOR>	
D669	8-719-991-33	DIODE 1SS133T-77					
D670	8-719-110-41	DIODE RD15ESB2		R602	Δ 1-219-236-91	SOLID 2.2M 20% 1/2W	



Les composants identifiés par une trame et une marque Δ sont critiques pour la sécurité. Ne les remplacer que par une pièce portant le numéro spécifique.

The components identified by shading and mark Δ are critical for safety. Replace only with part number specified.

REF. NO.	PART NO	DESCRIPTION	REMARK
R603	Δ 1-205-997-11	WIREWOUND 2.2	5% 10W
R604	Δ 1-247-891-91	CARBON 330K	5% 1/4W
R605	Δ 1-247-891-91	CARBON 330K	5% 1/4W
R606	Δ 1-202-933-61	FUSIBLE 0.1	10% 1/2W F
R607	1-247-891-00	CARBON 330K	5% 1/4W
R608	1-247-891-00	CARBON 330K	5% 1/4W
R609	1-216-369-00	METAL OXIDE 1	5% 2W F
R610	1-247-891-00	CARBON 330K	5% 1/4W
R611	1-247-891-00	CARBON 330K	5% 1/4W
R612	1-216-369-00	METAL OXIDE 1	5% 2W F
R613	1-247-791-91	CARBON 22	5% 1/4W
R614	1-247-791-91	CARBON 22	5% 1/4W
R615	1-247-791-91	CARBON 22	5% 1/4W
R616	1-247-791-91	CARBON 22	5% 1/4W
R631	1-247-863-91	CARBON 22K	5% 1/4W
R632	1-247-807-31	CARBON 100	5% 1/4W
R633	1-247-807-31	CARBON 100	5% 1/4W
R634	1-249-417-11	CARBON 1K	5% 1/4W
R635	1-249-425-11	CARBON 4 7K	5% 1/4W
R636	1-249-413-11	CARBON 470	5% 1/4W
R651	1-216-370-11	METAL OXIDE 1 2	5% 2W F
R653	1-249-418-11	CARBON 1 2K	5% 1/4W F
R654	1-215-473-00	METAL 150K	1% 1/4W
R655	1-249-441-11	CARBON 100K	5% 1/4W
R656	1-216-369-00	METAL OXIDE 1	5% 2W F
R657	1-249-429-11	CARBON 10K	5% 1/4W
R658	1-247-883-00	CARBON 150K	5% 1/4W
R659	1-249-417-11	CARBON 1K	5% 1/4W F
R660	1-249-417-11	CARBON 1K	5% 1/4W
R661	1-215-471-00	METAL 120K	1% 1/4W
R662	Δ 1-215-452-91	METAL 20K	1% 1/4W
R663	1-215-421-00	METAL 1K	1% 1/4W
R664	1-249-429-11	CARBON 10K	5% 1/4W
R665	1-249-425-11	CARBON 4 7K	5% 1/4W
R666	1-249-429-11	CARBON 10K	5% 1/4W
R667	1-249-429-11	CARBON 10K	5% 1/4W
R668	1-215-487-00	METAL 560K	1% 1/4W
R670	1-247-895-91	CARBON 470K	5% 1/4W
R671	1-249-429-11	CARBON 10K	5% 1/4W
R672	1-247-807-31	CARBON 100	5% 1/4W
R673	1-249-423-11	CARBON 3 3K	5% 1/4W
R674	1-249-413-11	CARBON 470	5% 1/4W
R675	1-249-429-11	CARBON 10K	5% 1/4W
R676	1-249-421-11	CARBON 2 2K	5% 1/4W
R677	1-249-417-11	CARBON 1K	5% 1/4W
R678	1-249-423-11	CARBON 3.3K	5% 1/4W
R679	1-249-423-11	CARBON 3 3K	5% 1/4W
R680	1-249-413-11	CARBON 470	5% 1/4W
R681	1-249-425-11	CARBON 4 7K	5% 1/4W
R682	1-249-403-11	CARBON 68	5% 1/4W
R683	1-249-417-11	CARBON 1K	5% 1/4W
R684	1-249-417-11	CARBON 1K	5% 1/4W
R685	1-247-863-91	CARBON 22K	5% 1/4W
R686	1-249-429-11	CARBON 10K	5% 1/4W
R687	1-249-423-11	CARBON 3 3K	5% 1/4W
R688	1-249-423-11	CARBON 3 3K	5% 1/4W
R689	1-249-429-11	CARBON 10K	5% 1/4W
R690	1-247-863-91	CARBON 22K	5% 1/4W
R691	1-249-417-11	CARBON 1K	5% 1/4W
R693	1-249-425-11	CARBON 4 7K	5% 1/4W
R694	1-249-425-11	CARBON 4 7K	5% 1/4W
R695	1-249-429-11	CARBON 10K	5% 1/4W
R697	1-249-413-11	CARBON 470	5% 1/4W
R698	1-249-429-11	CARBON 10K	5% 1/4W
R699	1-249-417-11	CARBON 1K	5% 1/4W

REF NO	PART NO	DESCRIPTION	REMARK
		<RELAY>	
RY601	Δ 1-755-032-11	RELAY	
RY602	Δ 1-755-032-11	RELAY	
		<TRANSFORMER>	
T601	Δ 1-427-850-11	TRANSFORMER, LINE FILTER	
T602	Δ 1-427-863-11	TRANSFORMER, CONVERTER (PIT)	
T603	Δ 1-427-865-11	TRANSFORMER, POWER	
T604	Δ 1-427-864-12	TRANSFORMER, CONVERTER (PRT)	
T605	Δ 1-427-850-11	TRANSFORMER, LINE FILTER	

	* A-1331-498-A	CR BOARD, COMPLETE	*****
		<CAPACITOR>	
C701	1-104-664-11	ELECT 47MF	20% 25V
C702	1-107-662-11	ELECT 22MF	20% 250V
C703	1-161-754-00	CERAMIC 0 001MF	10% 2KV
C704	1-126-768-11	ELECT 2200MF	20% 16V
C705	1-102-050-00	CERAMIC 0 01MF	500V
C706	1-102-953-00	CERAMIC 18PF	5% 50V
C707	1-102-129-00	CERAMIC 0 01MF	10% 50V
C708	1-104-664-11	ELECT 47MF	20% 25V
C709	1-107-651-11	ELECT 4 7MF	20% 250V
C710	1-102-157-00	CERAMIC 560PF	10% 500V
C714	1-162-115-00	CERAMIC 330PF	10% 2KV
C715	1-101-005-00	CERAMIC 0 022MF	50V
C716	1-102-050-00	CERAMIC 0 01MF	500V
		<CONNECTOR>	
CN701	* 1-508-784-00	PIN, CONNECTOR (5mm PITCH) 1P	
CN702	* 1-564-510-11	PLUG, CONNECTOR 7P	
CN703	* 1-564-512-11	PLUG, CONNECTOR 9P	
CN704	* 1-564-512-11	PLUG, CONNECTOR 9P	
CN705	* 1-564-511-11	PLUG, CONNECTOR 8P	
CN706	1-695-915-11	TAB (CONTACT)	
CN708	Δ 1-251-179-11	SOCKET, PICTURE TUBE	
CN709	* 1-564-506-11	PLUG, CONNECTOR 3P	
		<DIODE>	
D701	8-719-991-33	DIODE 1SS133T-77	
D702	8-719-991-33	DIODE 1SS133T-77	
D703	8-719-991-33	DIODE 1SS133T-77	
D704	8-719-921-86	DIODE MTZJ-13	
D705	8-719-210-21	DIODE 11EQS04	
D706	8-719-991-33	DIODE 1SS133T-77	
D707	8-719-921-86	DIODE MTZJ-13	
D708	8-719-901-83	DIODE 1SS83	
D710	8-719-109-89	DIODE RD5 6ESB2	
D711	8-719-991-33	DIODE 1SS133T-77	
D713	8-719-510-48	DIODE D1N20R	
D716	8-719-921-86	DIODE MTZJ-13	
D717	8-719-921-86	DIODE MTZJ-13	
		<IC>	
IC701	8-759-346-42	IC TDA6101Q/N3	
		<COIL>	
L701	1-408-429-00	INDUCTOR 470UH	

The components identified by shading and mark Δ are critical for safety. Replace only with part number specified.

Les composants identifiés par une trame et une marque Δ sont critiques pour la sécurité. Ne les remplacer que par une pièce portant le numéro spécifié.



REF NO.	PART NO	DESCRIPTION	REMARK		
<NEON LAMP>					
NL701	1-519-108-99	LAMP, NEON			
<TRANSISTOR>					
Q701	8-729-119-76	TRANSISTOR 2SA1175-HFE			
<RESISTOR>					
R701	1-215-411-00	METAL	390	1%	1/4W
R702	1-215-414-00	METAL	510	1%	1/4W
R704	1-202-847-00	SOLID	560K	20%	1/2W
R706	1-249-407-11	CARBON	150	5%	1/4W
R707	1-215-423-00	METAL	1 2K	1%	1/4W
R708	1-202-883-11	SOLID	680K	20%	1/2W
R709	1-215-437-00	METAL	4 7K	1%	1/4W
R710	1-215-427-00	METAL	1 8K	1%	1/4W
R711	1-215-427-00	METAL	1 8K	1%	1/4W
R712	1-215-903-11	METAL OXIDE	68K	5%	2W F
R713	1-202-818-00	SOLID	1K	20%	1/2W
R714	1-202-818-00	SOLID	1K	20%	1/2W
R715	1-249-436-11	CARBON	39K	5%	1/4W
R716	1-249-437-11	CARBON	47K	5%	1/4W
R718	1-249-417-11	CARBON	1K	5%	1/4W
R719	1-247-807-31	CARBON	100	5%	1/4W
R720	1-249-437-11	CARBON	47K	5%	1/4W
R721	1-202-549-00	SOLID	100	20%	1/2W
R722	1-202-549-00	SOLID	100	20%	1/2W
<SPARK GAP>					
SG701	1-519-422-11	GAP, SPARK			
SG702	1-519-422-11	GAP, SPARK			
SG703	1-519-422-11	GAP, SPARK			

* A-1331-499-A CG BOARD, COMPLETE *****					
<CAPACITOR>					
C731	1-161-754-00	CERAMIC	0 001MF	10%	2KV
C732	1-107-662-11	ELECT	22MF	20%	250V
C733	1-102-050-00	CERAMIC	0 01MF		500V
C736	1-126-964-11	ELECT	10MF	20%	50V
C738	1-107-651-11	ELECT	4 7MF	20%	250V
C739	1-102-965-00	CERAMIC	39PF	5%	50V
C740	1-126-964-11	ELECT	10MF	20%	50V
C741	1-102-157-00	CERAMIC	560PF	10%	500V
C742	1-162-115-00	CERAMIC	330PF	10%	2KV
C743	1-101-005-00	CERAMIC	0 022MF		50V
C744	1-102-050-00	CERAMIC	0 01MF		500V
<CONNECTOR>					
CN731	* 1-508-784-00	PIN, CONNECTOR (5mm PITCH) 1P			
CN732	* 1-564-512-11	PLUG, CONNECTOR 9P			
CN733	* 1-564-512-11	PLUG, CONNECTOR 9P			
CN734	* 1-564-511-11	PLUG, CONNECTOR 8P			
CN735	* 1-564-509-11	PLUG, CONNECTOR 6P			
CN736	1-695-915-11	TAB (CONTACT)			
CN738	Δ 1-251-179-11	SOCKET, PICTURE TUBE			

REF NO	PART NO	DESCRIPTION	REMARK		
<DIODE>					
D731	8-719-921-86	DIODE MTZJ-13			
D732	8-719-901-83	DIODE 1SS83			
D736	8-719-510-48	DIODE D1N20R			
D737	8-719-921-86	DIODE MTZJ-13			
<IC>					
IC731	8-759-346-42	IC TDA6101Q/N3			
<COIL>					
L731	1-408-429-00	INDUCTOR 470UH			
<NEON LAMP>					
NL731	1-519-108-99	LAMP, NEON			
<RESISTOR>					
R731	1-202-847-00	SOLID	560K	20%	1/2W
R733	1-202-883-11	SOLID	680K	20%	1/2W
R734	1-202-818-00	SOLID	1K	20%	1/2W
R735	1-249-407-11	CARBON	150	5%	1/4W
R736	1-249-441-11	CARBON	100K	5%	1/4W
R737	1-202-818-00	SOLID	1K	20%	1/2W
R738	1-202-549-00	SOLID	100	20%	1/2W
R739	1-215-420-00	METAL	910	1%	1/4W
R740	1-215-427-00	METAL	1 8K	1%	1/4W
R741	1-249-437-11	CARBON	47K	5%	1/4W
R742	1-215-903-11	METAL OXIDE	68K	5%	2W F
<SPARK GAP>					
SG731	1-519-422-11	GAP, SPARK			
SG732	1-519-422-11	GAP, SPARK			
SG733	1-519-422-11	GAP, SPARK			

* A-1331-500-A CB BOARD, COMPLETE *****					
<CAPACITOR>					
C761	1-161-754-00	CERAMIC	0 001MF	10%	2KV
C762	1-107-662-11	ELECT	22MF	20%	250V
C763	1-102-050-00	CERAMIC	0 01MF		500V
C766	1-107-651-11	ELECT	4 7MF	20%	250V
C769	1-102-965-00	CERAMIC	39PF	5%	50V
C770	1-126-964-11	ELECT	10MF	20%	50V
C771	1-102-157-00	CERAMIC	560PF	10%	500V
C772	1-162-115-00	CERAMIC	330PF	10%	2KV
C773	1-101-005-00	CERAMIC	0 022MF		50V
C774	1-102-050-00	CERAMIC	0 01MF		500V
<CONNECTOR>					
CN761	* 1-508-784-00	PIN, CONNECTOR (5mm PITCH) 1P			
CN762	* 1-564-512-11	PLUG, CONNECTOR 9P			
CN763	* 1-564-509-11	PLUG, CONNECTOR 6P			
CN766	1-695-915-11	TAB (CONTACT)			
CN768	Δ 1-251-179-11	SOCKET, PICTURE TUBE			
<DIODE>					
D761	8-719-921-86	DIODE MTZJ-13			



Les composants identifiés par une trame et une marque Δ sont critiques pour la sécurité. Ne les remplacer que par une pièce portant le numéro spécifique.

The components identified by shading and mark Δ are critical for safety. Replace only with part number specified.

REF NO	PART NO	DESCRIPTION	REMARK
D762	8-719-901-83	DIODE 1SS83	
D763	8-719-991-33	DIODE 1SS133T-77	
D764	8-719-921-86	DIODE MTZJ-13	
D765	8-719-921-86	DIODE MTZJ-13	
D768	8-719-510-48	DIODE D1N20R	
D769	8-719-921-86	DIODE MTZJ-13	
<IC>			
IC761	8-759-346-42	IC TDA6101Q/N3	
<COIL>			
L761	1-408-429-00	INDUCTOR 470UH	
<NEON LAMP>			
NL760	1-519-108-99	LAMP, NEON	
<RESISTOR>			
R761	1-202-847-00	SOLID 560K 20%	1/2W
R763	1-202-883-11	SOLID 680K 20%	1/2W
R764	1-202-818-00	SOLID 1K 20%	1/2W
R767	1-202-818-00	SOLID 1K 20%	1/2W
R768	1-202-549-00	SOLID 100 20%	1/2W
R769	1-215-421-00	METAL 1K 1%	1/4W
R770	1-249-426-11	CARBON 5 6K 5%	1/4W
R771	1-215-427-00	METAL 1 8K 1%	1/4W
R773	1-215-903-11	METAL OXIDE 68K 5%	2W F
R774	1-249-407-11	CARBON 150 5%	1/4W
R775	1-202-549-00	SOLID 100 20%	1/2W
<SPARK GAP>			
SG761	1-519-422-11	GAP, SPARK	
SG762	1-519-422-11	GAP, SPARK	
SG763	1-519-422-11	GAP, SPARK	

* A-1341-885-A E BOARD, COMPLETE *****			
4-382-854-11 SCREW (M3X10), P, SW (+)			
7-322-065-19 RUBBER, SILICON RTV (KE490W)			
<CAPACITOR>			
C801	1-110-626-11	ELECT 330MF 20%	160V
C802	1-163-251-11	CERAMIC CHIP 100PF 5%	50V
C803	1-110-626-11	ELECT 330MF 20%	160V
C805	1-136-173-00	FILM 0 47MF 5%	50V
C806	1-102-030-00	CERAMIC 330PF 10%	500V
C807	1-106-387-00	MYLAR 0 068MF 10%	200V
C808	1-107-636-11	ELECT 10MF 20%	160V
C809	1-104-664-11	ELECT 47MF 20%	25V
C810	1-130-481-00	FILM 0 0068MF 5%	50V
C811	1-137-475-11	FILM 2 2MF 10%	250V
C812	1-126-965-11	ELECT 22MF 20%	50V
C813	1-162-318-11	CERAMIC 0 001MF 10%	500V
C814	1-126-968-11	ELECT 100MF 20%	50V
C815	1-162-114-00	CERAMIC 0.0047MF	2KV
C818	Δ 1-109-833-11	FILM 0.0145MF 3%	2.5KV
C819	1-130-489-00	FILM 0 033MF 5%	50V
C820	1-124-902-00	ELECT 0 47MF 20%	50V
C823	1-136-601-11	FILM 0 01MF 5%	630V
C824	1-126-964-11	ELECT 10MF 20%	50V

REF NO	PART NO	DESCRIPTION	REMARK
C825	1-162-318-11	CERAMIC 0 001MF 10%	500V
C826	1-130-467-00	FILM 470PF 5%	50V
C827	1-107-651-11	ELECT 4 7MF 20%	250V
C828	1-111-036-11	ELECT 470MF 20%	16V
C830	1-137-420-11	FILM 0 047MF 10%	100V
C831	1-126-934-11	ELECT 220MF 20%	16V
C832	1-126-967-11	ELECT 47MF 20%	50V
C901	1-163-251-11	CERAMIC CHIP 100PF 5%	50V
C902	1-137-370-11	FILM 0 01MF 5%	50V
C903	1-137-431-11	FILM 560PF 5%	50V
C904	1-137-358-11	FILM 0 0001MF 5%	50V
C905	1-104-665-11	ELECT 100MF 20%	25V
C906	1-137-370-11	FILM 0 01MF 5%	50V
C907	1-104-665-11	ELECT 100MF 20%	25V
C908	1-137-361-11	FILM 330PF 5%	50V
C909	1-124-903-11	ELECT 1MF 20%	50V
C911	1-163-251-11	CERAMIC CHIP 100PF 5%	50V
C912	1-124-903-11	ELECT 1MF 20%	50V
C913	1-124-903-11	ELECT 1MF 20%	50V
C915	1-163-239-11	CERAMIC CHIP 33PF 5%	50V
C916	1-126-963-11	ELECT 4 7MF 20%	50V
C917	1-126-964-11	ELECT 10MF 20%	50V
C918	1-137-364-11	FILM 0.001MF 5%	50V
C919	1-126-964-11	ELECT 10MF 20%	50V
C920	1-124-902-00	ELECT 0 47MF 20%	50V
C921	1-126-964-11	ELECT 10MF 20%	50V
C923	1-126-964-11	ELECT 10MF 20%	50V
C924	1-126-935-11	ELECT 470MF 20%	16V
C925	1-137-372-11	FILM 0 022MF 5%	50V
C926	1-104-665-11	ELECT 100MF 20%	25V
C927	1-137-364-11	FILM 0 001MF 5%	50V
C929	1-137-416-11	FILM 0 01MF 10%	100V
C930	1-137-364-11	FILM 0 001MF 5%	50V
C931	1-126-967-11	ELECT 47MF 20%	50V
C932	1-124-903-11	ELECT 1MF 20%	50V
C934	1-137-370-11	FILM 0 01MF 5%	50V
C935	1-137-399-11	FILM 0 1MF 10%	100V
C936	1-126-964-11	ELECT 10MF 20%	50V
C937	1-126-964-11	ELECT 10MF 20%	50V
C938	1-126-935-11	ELECT 470MF 20%	16V
C939	1-126-964-11	ELECT 10MF 20%	50V
C940	1-104-664-11	ELECT 47MF 20%	25V
C941	1-126-964-11	ELECT 10MF 20%	50V
C942	1-104-664-11	ELECT 47MF 20%	25V
C943	1-126-965-11	ELECT 22MF 20%	50V
C944	1-126-964-11	ELECT 10MF 20%	50V
C945	1-126-964-11	ELECT 10MF 20%	50V
C946	1-124-925-11	ELECT 2 2MF 20%	50V
C947	1-104-665-11	ELECT 100MF 20%	25V
C948	1-104-665-11	ELECT 100MF 20%	25V
C949	1-126-964-11	ELECT 10MF 20%	50V
C950	1-126-964-11	ELECT 10MF 20%	50V
C951	1-109-889-11	ELECT 1MF 20%	50V
C955	1-126-964-11	ELECT 10MF 20%	50V
C980	1-137-368-11	FILM 0 0047MF 5%	50V
<CHIP CONDUCTOR>			
CJ901	1-216-295-91	CONDUCTOR, CHIP	
CJ902	1-216-295-91	CONDUCTOR, CHIP	
CJ903	1-216-295-91	CONDUCTOR, CHIP	
CJ904	1-216-295-91	CONDUCTOR, CHIP	
<CONNECTOR>			
CN802	* 1-564-510-11	PLUG, CONNECTOR 7P	
CN805	1-695-915-11	TAB (CONTACT)	
CN827	* 1-573-963-11	PIN, CONNECTOR (PC BOARD) 3P	
CN851	* 1-564-509-11	PLUG, CONNECTOR 6P	

The components identified by shading and mark Δ are critical for safety. Replace only with part number specified.

Les composants identifiés par une trame et une marque Δ sont critiques pour la sécurité. Ne les remplacer que par une pièce portant le numéro spécifié.

• The components identified by Δ in this manual have been carefully factory-selected for each set in order to satisfy regulations regarding X-ray radiation. Should replacement be required, replace only with the value originally used.



REF. NO	PART NO	DESCRIPTION	REMARK	REF. NO	PART NO	DESCRIPTION	REMARK
CN881	* 1-573-986-11	PIN, CONNECTOR (PC BOARD) 5P		L803	1-422-613-11	COIL, AIR CORE	
CN882	* 1-691-135-11	PIN, CONNECTOR (PC BOARD) 4P		L804	1-411-286-11	COIL, CHOKE 220UH	
CN884	* 1-573-964-11	PIN, CONNECTOR (PC BOARD) 6P		L901	1-408-416-00	INDUCTOR 39UH	
CN885	* 1-506-371-00	PIN, CONNECTOR 2P		L902	1-408-416-00	INDUCTOR 39UH	
CN886	* 1-506-371-00	PIN, CONNECTOR 2P				<NEON LAMP>	
CN904	* 1-564-507-11	PLUG, CONNECTOR 4P		NL802	1-519-108-99	LAMP, NEON	
		<DIODE>				<TRANSISTOR>	
D801	8-719-109-85	DIODE RD5 1ESB2		Q801	8-729-119-80	TRANSISTOR 2SC2688-LK	
D802	8-719-404-46	DIODE MA110		Q802	8-729-119-80	TRANSISTOR 2SC2688-LK	
D803	8-719-971-20	DIODE ERC38-06		Q803	8-729-122-12	TRANSISTOR 2SA1221-L	
D804	8-719-908-03	DIODE GP08D		Q806	8-729-805-07	TRANSISTOR 2SD1887-CA	
D805	8-719-945-80	DIODE ERC06-15S		Q807	8-729-422-27	TRANSISTOR 2SD601A-Q	
D806	8-719-991-33	DIODE ISS133T-77		Q808	8-729-024-30	TRANSISTOR IRFI640LF	
D807	8-719-945-80	DIODE ERC06-15S		Q809	8-729-823-81	TRANSISTOR 2SC4632LS-CB7	
D808	8-719-500-71	DIODE D8LC40		Q810	8-729-231-55	TRANSISTOR 2SC2878-AB	
D809	8-719-991-33	DIODE ISS133T-77		Q811	8-729-823-81	TRANSISTOR 2SC4632LS-CB7	
D810	8-719-945-80	DIODE ERC06-15S		Q813	8-729-216-22	TRANSISTOR 2SA1162-G	
D811	8-719-979-85	DIODE EGP20G-PKG23		Q901	8-729-422-27	TRANSISTOR 2SD601A-Q	
D812	8-719-404-46	DIODE MA110		Q902	8-729-140-93	TRANSISTOR 2SB733-34	
D814	8-719-920-67	DIODE ERC91-02		Q903	8-729-140-96	TRANSISTOR 2SD774-34	
D816	8-719-404-46	DIODE MA110		Q904	8-729-422-27	TRANSISTOR 2SD601A-Q	
D817	8-719-404-46	DIODE MA110		Q905	8-729-422-27	TRANSISTOR 2SD601A-Q	
D818	8-719-404-46	DIODE MA110		Q906	8-729-422-27	TRANSISTOR 2SD601A-Q	
D819	8-719-105-82	DIODE RD5.1M-B2		Q907	8-729-231-55	TRANSISTOR 2SC2878-AB	
D901	8-719-404-46	DIODE MA110		Q908	8-729-422-27	TRANSISTOR 2SD601A-Q	
D902	8-719-404-46	DIODE MA110		Q909	8-729-422-27	TRANSISTOR 2SD601A-Q	
D904	8-719-404-46	DIODE MA110		Q910	8-729-422-27	TRANSISTOR 2SD601A-Q	
D905	8-719-404-46	DIODE MA110		Q911	8-729-422-27	TRANSISTOR 2SD601A-Q	
D907	8-719-404-46	DIODE MA110		Q912	8-729-216-22	TRANSISTOR 2SA1162-G	
D908	8-719-105-82	DIODE RD5.1M-B2		Q913	8-729-029-86	TRANSISTOR DTC124ESA	
D909	8-719-302-43	DIODE EL1Z		Q914	8-729-422-27	TRANSISTOR 2SD601A-Q	
D911	8-719-105-82	DIODE RD5.1M-B2		Q915	8-729-422-27	TRANSISTOR 2SD601A-Q	
D912	8-719-105-82	DIODE RD5.1M-B2				<RESISTOR>	
D913	8-719-404-46	DIODE MA110		R800	1-216-637-11	METAL CHIP 270	0.50% 1/10W
D914	8-719-404-46	DIODE MA110		R801	1-216-033-00	METAL GLAZE 220	5% 1/10W
D915	8-719-404-46	DIODE MA110		R802	1-249-421-11	CARBON 2 2K	5% 1/4W
D916	8-719-105-57	DIODE RD3 9M-B1		R804	1-249-425-11	CARBON 4 7K	5% 1/4W F
D917	8-719-404-46	DIODE MA110		R805	1-216-435-11	METAL OXIDE 2 7K	5% 1W F
D918	8-719-404-46	DIODE MA110		R806	1-249-431-11	CARBON 15K	5% 1/4W F
D919	8-719-106-81	DIODE RD13M-B3		R807	1-260-325-11	CARBON 560	5% 1/2W
D920	8-759-157-40	IC uPC574J		Δ R808	Δ	CARBON	1/4W
D921	8-719-106-81	DIODE RD13M-B3		Δ R809	Δ	CARBON	1/4W
D922	8-719-404-46	DIODE MA110		R810	1-249-427-11	CARBON 6 8K	5% 1/4W F
D923	8-719-404-46	DIODE MA110		R811	1-216-097-91	METAL GLAZE 100K	5% 1/10W
D924	8-719-404-46	DIODE MA110		R812	1-216-395-00	METAL OXIDE 3 3	5% 3W F
D925	8-719-028-00	DIODE MA3033-L		R813	1-216-484-00	METAL OXIDE 3 9K	5% 3W F
D926	8-719-404-46	DIODE MA110		R814	1-215-919-11	METAL OXIDE 2 2K	5% 3W F
D927	8-719-401-32	DIODE MA3047M-TX		R816	1-216-051-00	METAL GLAZE 1 2K	5% 1/10W
		<FERRITE BEAD>		R817	1-216-395-00	METAL OXIDE 3 3	5% 3W F
FB001	1-410-396-41	FERRITE BEAD INDUCTOR 0 45UH		R818	1-249-405-11	CARBON 100	5% 1/4W F
		<IC>		R819	1-216-089-91	METAL GLAZE 47K	5% 1/10W
IC901	8-759-133-90	IC uPC339C		R820	1-215-905-11	METAL OXIDE 10	5% 3W F
IC902	8-759-133-90	IC uPC339C		R821	1-216-073-00	METAL GLAZE 10K	5% 1/10W
IC903	8-759-711-28	IC NJM2058D		R822	1-215-928-11	METAL OXIDE 68K	5% 3W F
IC904	8-759-634-51	IC M5218AP		R823	1-216-041-00	METAL GLAZE 470	5% 1/10W
IC905	8-759-929-65	IC LM7912CT		R825	1-215-928-11	METAL OXIDE 68K	5% 3W F
IC906	8-759-279-76	IC MCT7812CT		R826	1-216-033-00	METAL GLAZE 220	5% 1/10W
		<COIL>		R830	1-215-928-11	METAL OXIDE 68K	5% 3W F
L801	1-406-665-11	COIL, CHOKE 100UH		R831	1-215-919-11	METAL OXIDE 2.2K	5% 3W F
L802	1-406-665-11	COIL, CHOKE 100UH		R832	1-216-049-91	METAL GLAZE 1K	5% 1/10W
				R836	1-202-818-00	SOLID 1K	20% 1/2W
				R837	1-215-870-11	METAL OXIDE 1.5K	5% 1W F
				R838	1-247-807-31	CARBON 100	5% 1/4W



• The components identified by **E** in this manual have been carefully factory-selected for each set in order to satisfy regulations regarding X-ray radiation. Should replacement be required, replace only with the value originally used.

Les composants identifiés par une trame et une marque **E** sont critiques pour la sécurité. Ne les remplacer que par une pièce portant le numéro spécifié.

The components identified by shading and mark **E** are critical for safety. Replace only with part number specified.

REF NO	PART NO	DESCRIPTION	REMARK
R839	1-249-429-11	CARBON 10K	5% 1/4W F
R841	1-216-491-11	METAL OXIDE 56K	5% 3W F
R843	1-202-549-00	SOLID 100	20% 1/2W
R844	1-216-491-11	METAL OXIDE 56K	5% 3W F
R846	1-202-838-00	SOLID 100K	20% 1/2W
R847	1-216-073-00	METAL GLAZE 10K	5% 1/10W
R849	1-247-863-91	CARBON 22K	5% 1/4W
R850	1-216-081-00	METAL GLAZE 22K	5% 1/10W
R851	1-216-667-11	METAL CHIP 47K	0.50% 1/10W
R852	1-208-806-11	METAL CHIP 10K	0.50% 1/10W
R854	1-249-447-11	CARBON 1	5% 1/4W F
R855	1-208-822-11	METAL CHIP 47K	0.50% 1/10W
R856	1-208-822-11	METAL CHIP 47K	0.50% 1/10W
R857	1-216-699-11	METAL CHIP 100K	0.50% 1/10W
R858	1-208-810-11	METAL CHIP 15K	0.50% 1/10W
R865	1-216-350-11	METAL OXIDE 1 2	5% 1W F
R866	1-532-781-11	FUSE, MICRO (SECONDARY) 3 15A/125V	
R883	1-216-091-00	METAL GLAZE 56K	5% 1/10W
R888	1-216-067-00	METAL GLAZE 5 6K	5% 1/10W
R901	1-216-065-00	METAL GLAZE 4 7K	5% 1/10W
R902	1-216-065-00	METAL GLAZE 4 7K	5% 1/10W
R903	1-216-085-00	METAL GLAZE 33K	5% 1/10W
R904	1-216-057-00	METAL GLAZE 2 2K	5% 1/10W
R905	1-247-739-11	CARBON 100	5% 1/2W F
R906	1-247-739-11	CARBON 100	5% 1/2W F
R907	1-216-091-00	METAL GLAZE 56K	5% 1/10W
R908	1-216-085-00	METAL GLAZE 33K	5% 1/10W
R909	1-216-113-00	METAL GLAZE 470K	5% 1/10W
R910	1-216-059-00	METAL GLAZE 2 7K	5% 1/10W
R911	1-216-059-00	METAL GLAZE 2 7K	5% 1/10W
R912	1-216-073-00	METAL GLAZE 10K	5% 1/10W
R913	1-216-077-00	METAL GLAZE 15K	5% 1/10W
R914	1-216-049-91	METAL GLAZE 1K	5% 1/10W
R915	1-216-091-00	METAL GLAZE 56K	5% 1/10W
R916	1-216-065-00	METAL GLAZE 4 7K	5% 1/10W
R917	1-216-057-00	METAL GLAZE 2 2K	5% 1/10W
R918	1-216-073-00	METAL GLAZE 10K	5% 1/10W
R919	1-216-077-00	METAL GLAZE 15K	5% 1/10W
R920	1-216-113-00	METAL GLAZE 470K	5% 1/10W
R921	1-216-059-00	METAL GLAZE 2 7K	5% 1/10W
R922	1-216-073-00	METAL GLAZE 10K	5% 1/10W
R923	1-216-077-00	METAL GLAZE 15K	5% 1/10W
R924	1-216-067-00	METAL GLAZE 5 6K	5% 1/10W
R926	1-216-049-91	METAL GLAZE 1K	5% 1/10W
R927	1-249-377-11	CARBON 0 47	5% 1/4W F
R928	1-216-067-00	METAL GLAZE 5 6K	5% 1/10W
R929	1-216-041-00	METAL GLAZE 470	5% 1/10W
R930	1-216-081-00	METAL GLAZE 22K	5% 1/10W
R931	1-216-059-00	METAL GLAZE 2 7K	5% 1/10W
R932	1-216-059-00	METAL GLAZE 2 7K	5% 1/10W
R933	1-216-081-00	METAL GLAZE 22K	5% 1/10W
R934	1-216-085-00	METAL GLAZE 33K	5% 1/10W
R935	1-216-049-91	METAL GLAZE 1K	5% 1/10W
R936	1-216-065-00	METAL GLAZE 4.7K	5% 1/10W
R937	1-216-049-91	METAL GLAZE 1K	5% 1/10W
R938	1-208-810-11	METAL CHIP 15K	0.50% 1/10W
R939	1-216-073-00	METAL GLAZE 10K	5% 1/10W
R940	1-216-083-00	METAL GLAZE 27K	5% 1/10W
R941	1-216-091-00	METAL GLAZE 56K	5% 1/10W
R942	1-216-049-91	METAL GLAZE 1K	5% 1/10W
R943	1-249-377-11	CARBON 0 47	5% 1/4W F
R944	1-216-689-11	METAL GLAZE 39K	5% 1/10W
R945	1-216-077-00	METAL GLAZE 15K	5% 1/10W
R946	1-216-073-00	METAL GLAZE 10K	5% 1/10W
R947	1-216-025-91	METAL GLAZE 100	5% 1/10W
R948	1-216-051-00	METAL GLAZE 1 2K	5% 1/10W
R950	1-216-049-91	METAL GLAZE 1K	5% 1/10W
R952	1-216-049-91	METAL GLAZE 1K	5% 1/10W
R954	1-214-777-00	METAL 100K	1% 1/4W

REF NO	PART NO	DESCRIPTION	REMARK
R955	1-214-769-00	METAL 47K	1% 1/4W
R956	1-208-806-11	METAL CHIP 10K	0.50% 1/10W
R957	1-218-754-11	METAL CHIP 120K	0.50% 1/10W
R958	1-218-756-11	METAL CHIP 150K	0.50% 1/10W
R959	1-214-757-00	METAL 15K	1% 1/4W
R960	1-216-077-00	METAL GLAZE 15K	5% 1/10W
R962	1-208-806-11	METAL CHIP 10K	0.50% 1/10W
R963	1-214-749-00	METAL 6 8K	1% 1/4W
R964	1-214-757-00	METAL 15K	1% 1/4W
R965	1-216-097-91	METAL GLAZE 100K	5% 1/10W
R966	1-214-757-00	METAL 15K	1% 1/4W
R967	1-216-025-91	METAL GLAZE 100	5% 1/10W
R968	1-214-751-00	METAL 8 2K	1% 1/4W
R969	1-214-731-00	METAL 1 2K	1% 1/4W
R970	1-214-757-00	METAL 15K	1% 1/4W
R971	1-216-121-91	METAL GLAZE 1M	5% 1/10W
R972	1-216-699-11	METAL CHIP 100K	0.50% 1/10W
R973	1-216-081-00	METAL GLAZE 22K	5% 1/10W
R974	1-216-699-11	METAL CHIP 100K	0.50% 1/10W
R975	1-216-043-91	METAL GLAZE 560	5% 1/10W
R976	1-216-041-00	METAL GLAZE 470	5% 1/10W
R977	1-216-075-00	METAL GLAZE 12K	5% 1/10W
R978	1-216-057-00	METAL GLAZE 2 2K	5% 1/10W
R979	1-216-075-00	METAL GLAZE 12K	5% 1/10W
R980	1-216-081-00	METAL GLAZE 22K	5% 1/10W
R981	1-216-073-00	METAL GLAZE 10K	5% 1/10W
R982	1-216-671-11	METAL CHIP 6.8K	0.50% 1/10W
R983	1-216-083-00	METAL GLAZE 27K	5% 1/10W
R984	1-208-812-11	METAL CHIP 18K	0.50% 1/10W
R985	1-216-049-91	METAL GLAZE 1K	5% 1/10W
R986	1-216-059-00	METAL GLAZE 2.7K	5% 1/10W
R987	1-216-059-00	METAL GLAZE 2.7K	5% 1/10W
R988	1-216-462-00	METAL OXIDE 8 2K	5% 2W F
R989	1-215-897-11	METAL OXIDE 6 8K	5% 2W F
R990	1-208-801-11	METAL CHIP 6 2K	0.50% 1/10W
R991	1-249-431-11	CARBON 15K	5% 1/4W
R992	1-249-431-11	CARBON 15K	5% 1/4W
R993	1-247-807-31	CARBON 100	5% 1/4W
R994	1-216-677-11	METAL CHIP 12K	0.50% 1/10W
R995	1-208-814-11	METAL CHIP 22K	0.50% 1/10W
R996	1-216-065-00	METAL GLAZE 4 7K	5% 1/10W
R997	1-216-073-00	METAL GLAZE 10K	5% 1/10W
R998	1-216-051-00	METAL GLAZE 1 2K	5% 1/10W
R999	1-216-051-00	METAL GLAZE 1 2K	5% 1/10W
SG801	1-519-422-11	GAP, SPARK	
T801	1-453-189-11	TRANSFORMER ASSY, FLYBACK	
T802	1-437-209-11	TRANSFORMER, HORIZONTAL DRIVE	
T803	1-427-980-11	TRANSFORMER, FERRITE (LOT)	

* A-1346-296-A D BOARD, COMPLETE *****			
4-382-854-11 SCREW (M3X10), P, SW (+)			
7-682-652-09 SCREW +PSW 3X16			
<CAPACITOR>			
C1502	1-126-943-11	ELECT 2200MF	20% 25V
C1503	1-164-232-11	CERAMIC CHIP 0 01MF	10% 50V



REF. NO.	PART NO.	DESCRIPTION	REMARK	REF. NO.	PART NO.	DESCRIPTION	REMARK
C1504	1-126-943-11	ELECT	2200MF 20%	C1834	1-163-809-11	CERAMIC CHIP 0 047MF	10% 25V
C1505	1-136-177-00	FILM	1MF 5%	C1835	1-163-809-11	CERAMIC CHIP 0 047MF	10% 25V
C1506	1-102-228-00	CERAMIC	470PF 10%	C1836	1-163-809-11	CERAMIC CHIP 0 047MF	10% 25V
C1507	1-164-232-11	CERAMIC CHIP	0 01MF 10%	C1837	1-164-489-11	CERAMIC CHIP 0 22MF	10% 16V
C1508	1-163-251-11	CERAMIC CHIP	100PF 5%	C1838	1-126-968-11	ELECT	100MF 20% 50V
C1509	1-126-968-11	ELECT	100MF 20%	C1839	1-126-968-11	ELECT	100MF 20% 50V
C1510	1-137-401-11	FILM	0 22MF 10%	C1840	1-124-903-11	ELECT	1MF 20% 50V
C1511	1-137-423-11	FILM	0 15MF 10%	C1841	1-126-967-11	ELECT	47MF 20% 50V
C1512	1-137-423-11	FILM	0 15MF 10%	C1842	1-163-251-11	CERAMIC CHIP	100PF 5% 50V
C1513	1-163-243-11	CERAMIC CHIP	47PF 5%	C1843	1-163-251-11	CERAMIC CHIP	100PF 5% 50V
C1514	1-163-031-11	CERAMIC CHIP	0 01MF 50V	C1844	1-126-967-11	ELECT	47MF 20% 50V
C1515	1-163-031-11	CERAMIC CHIP	0 01MF 50V	C1845	1-163-809-11	CERAMIC CHIP 0 047MF	10% 25V
C1516	1-136-177-00	FILM	1MF 5%	C1846	1-163-809-11	CERAMIC CHIP 0 047MF	10% 25V
C1517	1-163-125-00	CERAMIC CHIP	220PF 5%	C1847	1-163-809-11	CERAMIC CHIP 0 047MF	10% 25V
C1551	1-126-964-11	ELECT	10MF 20%	C1848	1-163-809-11	CERAMIC CHIP 0.047MF	10% 25V
C1603	1-163-251-11	CERAMIC CHIP	100PF 5%	C1849	1-126-968-11	ELECT	100MF 20% 50V
C1604	1-163-251-11	CERAMIC CHIP	100PF 5%	C1850	1-126-968-11	ELECT	100MF 20% 50V
C1605	1-163-251-11	CERAMIC CHIP	100PF 5%	C1851	1-137-399-11	FILM	0 1MF 5% 50V
C1606	1-163-251-11	CERAMIC CHIP	100PF 5%	C1852	1-126-968-11	ELECT	100MF 20% 50V
C1607	1-163-251-11	CERAMIC CHIP	100PF 5%	C1853	1-137-378-11	FILM	0 22MF 5% 50V
C1608	1-163-251-11	CERAMIC CHIP	100PF 5%	C1854	1-126-963-11	ELECT	4 7MF 20% 50V
C1611	1-126-968-11	ELECT	100MF 20%	C1855	1-124-903-11	ELECT	1MF 20% 50V
C1612	1-104-665-11	ELECT	100MF 20%	C1856	1-104-665-11	ELECT	100MF 20% 25V
C1613	1-126-968-11	ELECT	100MF 20%	C1857	1-126-968-11	ELECT	100MF 20% 50V
C1615	1-104-665-11	ELECT	100MF 20%	C1858	1-163-809-11	CERAMIC CHIP 0 047MF	10% 25V
C1617	1-126-941-11	ELECT	470MF 20%	C1859	1-163-809-11	CERAMIC CHIP 0 047MF	10% 25V
C1619	1-104-665-11	ELECT	100MF 20%	C1860	1-163-809-11	CERAMIC CHIP 0.047MF	10% 25V
C1620	1-126-941-11	ELECT	470MF 20%	C1861	1-126-968-11	ELECT	100MF 20% 50V
C1622	1-104-665-11	ELECT	100MF 20%	C1862	1-124-903-11	ELECT	1MF 20% 50V
C1701	1-126-935-11	ELECT	470MF 20%	C1863	1-136-173-00	FILM	0 47MF 5% 50V
C1702	1-163-809-11	CERAMIC CHIP	0 047MF 10%	C1864	1-124-903-11	ELECT	1MF 20% 50V
C1703	1-163-099-00	CERAMIC CHIP	18PF 5%	C1865	1-124-903-11	ELECT	1MF 20% 50V
C1704	1-163-125-00	CERAMIC CHIP	220PF 5%	C1866	1-126-967-11	ELECT	47MF 20% 50V
C1705	1-163-099-00	CERAMIC CHIP	18PF 5%			<CHIP CONDUCTOR>	
C1709	1-163-031-11	CERAMIC CHIP	0 01MF 50V	CJ1	1-216-295-91	CONDUCTOR, CHIP	
C1723	1-163-251-11	CERAMIC CHIP	100PF 5%	CJ2	1-216-295-91	CONDUCTOR, CHIP	
C1724	1-163-251-11	CERAMIC CHIP	100PF 5%	CJ3	1-216-295-91	CONDUCTOR, CHIP	
C1801	1-124-903-11	ELECT	1MF 20%	CJ4	1-216-295-91	CONDUCTOR, CHIP	
C1802	1-126-964-11	ELECT	10MF 20%	CJ5	1-216-295-91	CONDUCTOR, CHIP	
C1803	1-163-809-11	CERAMIC CHIP	0 047MF 10%	CJ6	1-216-295-91	CONDUCTOR, CHIP	
C1805	1-163-809-11	CERAMIC CHIP	0 047MF 10%	CJ7	1-216-295-91	CONDUCTOR, CHIP	
C1806	1-163-127-00	CERAMIC CHIP	270PF 5%	CJ8	1-216-295-91	CONDUCTOR, CHIP	
C1807	1-163-809-11	CERAMIC CHIP	0 047MF 10%	CJ9	1-216-295-91	CONDUCTOR, CHIP	
C1808	1-163-809-11	CERAMIC CHIP	0.047MF 10%	CJ10	1-216-295-91	CONDUCTOR, CHIP	
C1809	1-104-661-91	ELECT	330MF 20%	CJ11	1-216-295-91	CONDUCTOR, CHIP	
C1810	1-104-661-91	ELECT	330MF 20%	CJ12	1-216-295-91	CONDUCTOR, CHIP	
C1811	1-163-809-11	CERAMIC CHIP	0 047MF 10%	CJ13	1-216-295-91	CONDUCTOR, CHIP	
C1812	1-163-809-11	CERAMIC CHIP	0 047MF 10%	CJ14	1-216-295-91	CONDUCTOR, CHIP	
C1813	1-163-275-11	CERAMIC CHIP	0 001MF 5%	CJ15	1-216-295-91	CONDUCTOR, CHIP	
C1814	1-163-809-11	CERAMIC CHIP	0 047MF 10%	CJ16	1-216-295-91	CONDUCTOR, CHIP	
C1816	1-163-251-11	CERAMIC CHIP	100PF 5%	CJ17	1-216-295-91	CONDUCTOR, CHIP	
C1817	1-163-251-11	CERAMIC CHIP	100PF 5%	CJ18	1-216-295-91	CONDUCTOR, CHIP	
C1818	1-163-809-11	CERAMIC CHIP	0 047MF 10%	CJ19	1-216-295-91	CONDUCTOR, CHIP	
C1819	1-126-933-11	ELECT	100MF 20%	CJ20	1-216-295-91	CONDUCTOR, CHIP	
C1820	1-163-005-11	CERAMIC CHIP	470PF 10%	CJ21	1-216-295-91	CONDUCTOR, CHIP	
C1821	1-124-902-00	ELECT	0 47MF 20%	CJ22	1-216-295-91	CONDUCTOR, CHIP	
C1822	1-163-005-11	CERAMIC CHIP	470PF 10%	CJ23	1-216-295-91	CONDUCTOR, CHIP	
C1823	1-124-903-11	ELECT	1MF 20%	CJ24	1-216-295-91	CONDUCTOR, CHIP	
C1824	1-124-903-11	ELECT	1MF 20%	CJ25	1-216-295-91	CONDUCTOR, CHIP	
C1825	1-126-967-11	ELECT	47MF 20%	CJ26	1-216-295-91	CONDUCTOR, CHIP	
C1826	1-126-967-11	ELECT	47MF 20%	CJ27	1-216-295-91	CONDUCTOR, CHIP	
C1827	1-163-809-11	CERAMIC CHIP	0 047MF 10%	CJ28	1-216-295-91	CONDUCTOR, CHIP	
C1828	1-163-809-11	CERAMIC CHIP	0 047MF 10%	CJ29	1-216-295-91	CONDUCTOR, CHIP	
C1829	1-163-809-11	CERAMIC CHIP	0 047MF 10%	CJ30	1-216-295-91	CONDUCTOR, CHIP	
C1830	1-163-809-11	CERAMIC CHIP	0 047MF 10%	CJ31	1-216-295-91	CONDUCTOR, CHIP	
C1831	1-104-661-91	ELECT	330MF 20%	CJ32	1-216-295-91	CONDUCTOR, CHIP	
C1832	1-104-661-91	ELECT	330MF 20%	CJ33	1-216-295-91	CONDUCTOR, CHIP	
C1833	1-163-809-11	CERAMIC CHIP	0 047MF 10%				

D

Les composants identifiés par une trame et une marque Δ sont critiques pour la sécurité. Ne les remplacer que par une pièce portant le numéro spécifié.

The components identified by shading and mark Δ are critical for safety. Replace only with part number specified.

REF. NO	PART NO	DESCRIPTION	REMARK
CJ34	1-216-295-91	CONDUCTOR, CHIP	
CJ35	1-216-295-91	CONDUCTOR, CHIP	
CJ36	1-216-295-91	CONDUCTOR, CHIP	
CJ37	1-216-295-91	CONDUCTOR, CHIP	
CJ38	1-216-295-91	CONDUCTOR, CHIP	
CJ39	1-216-295-91	CONDUCTOR, CHIP	
CJ40	1-216-295-91	CONDUCTOR, CHIP	
CJ42	1-216-295-91	CONDUCTOR, CHIP	
CJ43	1-216-295-91	CONDUCTOR, CHIP	
CJ44	1-216-295-91	CONDUCTOR, CHIP	
CJ45	1-216-295-91	CONDUCTOR, CHIP	
CJ46	1-216-295-91	CONDUCTOR, CHIP	
CJ47	1-216-295-91	CONDUCTOR, CHIP	
CJ48	1-216-295-91	CONDUCTOR, CHIP	
CJ49	1-216-295-91	CONDUCTOR, CHIP	
CJ50	1-216-295-91	CONDUCTOR, CHIP	
CJ51	1-216-295-91	CONDUCTOR, CHIP	
CJ52	1-216-295-91	CONDUCTOR, CHIP	
CJ53	1-216-295-91	CONDUCTOR, CHIP	
CJ54	1-216-295-91	CONDUCTOR, CHIP	
CJ56	1-216-295-91	CONDUCTOR, CHIP	
CJ57	1-216-295-91	CONDUCTOR, CHIP	
CJ58	1-216-295-91	CONDUCTOR, CHIP	
CJ59	1-216-295-91	CONDUCTOR, CHIP	
CJ60	1-216-295-91	CONDUCTOR, CHIP	
CJ62	1-216-295-91	CONDUCTOR, CHIP	
CJ63	1-216-295-91	CONDUCTOR, CHIP	
<CONNECTOR>			
CN1509	* 1-564-506-11	PLUG, CONNECTOR 3P	
CN1513	* 1-564-506-11	PLUG, CONNECTOR 3P	
CN1612	* 1-564-507-11	PLUG, CONNECTOR 4P	
CN1642	* 1-564-507-11	PLUG, CONNECTOR 4P	
CN1672	* 1-564-507-11	PLUG, CONNECTOR 4P	
CN1716	* 1-564-507-11	PLUG, CONNECTOR 4P	
CN1756	* 1-564-508-11	PLUG, CONNECTOR 5P	
CN1757	* 1-564-516-11	PLUG, CONNECTOR 13P	
<DIODE>			
D1501	8-719-908-03	DIODE GP08D	
D1502	8-719-109-89	DIODE RD5 6ESB2	
D1503	8-719-971-20	DIODE ERC38-06	
D1505	8-719-109-89	DIODE RD5 6ESB2	
D1551	8-719-983-14	DIODE MTZJ-T-77-3 9	
D1552	8-719-991-33	DIODE 1SS133T-77	
D1553	8-719-991-33	DIODE 1SS133T-77	
D1601	8-719-908-03	DIODE GP08D	
D1602	8-719-908-03	DIODE GP08D	
D1603	8-719-908-03	DIODE GP08D	
D1604	8-719-908-03	DIODE GP08D	
D1803	8-719-991-33	DIODE 1SS133T-77	
D1812	8-719-991-33	DIODE 1SS133T-77	
D1814	8-719-991-33	DIODE 1SS133T-77	
D1825	8-719-991-33	DIODE 1SS133T-77	
D1826	8-719-991-33	DIODE 1SS133T-77	
D1827	8-719-982-03	DIODE MTZJ-3 6A	
D1931	8-719-924-16	DIODE MTZJ-T-77-24	
D1932	8-719-924-16	DIODE MTZJ-T-77-24	
D1934	8-719-924-16	DIODE MTZJ-T-77-24	
D1935	8-719-924-16	DIODE MTZJ-T-77-24	
D1936	8-719-924-16	DIODE MTZJ-T-77-24	
D1937	8-719-924-16	DIODE MTZJ-T-77-24	
D1942	8-719-924-16	DIODE MTZJ-T-77-24	
D1945	8-719-924-16	DIODE MTZJ-T-77-24	
D1946	8-719-924-16	DIODE MTZJ-T-77-24	
D1947	8-719-924-16	DIODE MTZJ-T-77-24	
D1948	8-719-921-86	DIODE MTZJ-13	

REF. NO	PART NO	DESCRIPTION	REMARK
D1949	8-719-924-16	DIODE MTZJ-T-77-24	
D1951	8-719-921-86	DIODE MTZJ-13	
D1953	8-719-921-86	DIODE MTZJ-13	
D1954	8-719-921-86	DIODE MTZJ-13	
<FUSE>			
F1601	Δ 1-532-745-11	FUSE, GLASS TUBE 3.15A/125V	
	1-533-223-11	CLIP, FUSE ; F1601	
F1602	Δ 1-532-745-11	FUSE, GLASS TUBE 3.15A/125V	
	1-533-223-11	CLIP, FUSE ; F1602	
<IC>			
IC1501	8-759-192-71	IC STV9379	
IC1601	8-749-010-88	IC STK392-010	
IC1602	8-749-010-88	IC STK392-010	
IC1701	8-752-861-57	IC CXP85112B-613S	
IC1702	8-759-041-54	IC MN1382S	
IC1801	8-759-327-52	IC PM0002B	
IC1802	8-759-327-51	IC PA0053B	
IC1803	8-759-012-67	IC MC7905CT	
IC1803	8-759-929-64	IC LM7905CT	
IC1804	8-759-231-53	IC TA7805S	
IC1804	8-759-231-53	IC TA7805S	
IC1805	8-759-327-52	IC PM0002B	
IC1806	8-759-327-51	IC PA0053B	
IC1807	8-759-929-65	IC LM7912CT	
IC1807	8-759-929-65	IC LM7912CT	
IC1808	8-759-279-76	IC MCT7812CT	
IC1808	8-759-231-58	IC TA7812S	
IC1809	8-759-327-52	IC PM0002B	
IC1931	8-759-711-28	IC NJM2058D	
IC1932	8-759-711-28	IC NJM2058D	
<COIL>			
L1501	1-412-533-21	INDUCTOR 47UH	
L1502	1-412-533-21	INDUCTOR 47UH	
L1503	1-412-524-11	INDUCTOR 8 2UH	
L1515	1-410-470-11	INDUCTOR 10UH	
L1516	1-410-482-31	INDUCTOR 100UH	
L1701	1-410-470-11	INDUCTOR 10UH	
L1801	1-406-975-21	COIL, CHOKE 47UH	
L1802	1-406-975-21	COIL, CHOKE 47UH	
<TRANSISTOR>			
Q1501	8-729-422-27	TRANSISTOR 2SD601A-Q	
Q1502	8-729-422-27	TRANSISTOR 2SD601A-Q	
Q1551	8-729-216-22	TRANSISTOR 2SA1162-G	
Q1552	8-729-422-27	TRANSISTOR 2SD601A-Q	
Q1701	8-729-422-27	TRANSISTOR 2SD601A-Q	
Q1801	8-729-422-27	TRANSISTOR 2SD601A-Q	
Q1802	8-729-216-22	TRANSISTOR 2SA1162-G	
Q1803	8-729-029-86	TRANSISTOR DTC124ESA	
Q1804	8-729-422-27	TRANSISTOR 2SD601A-Q	
Q1805	8-729-029-86	TRANSISTOR DTC124ESA	
<RESISTOR>			
R1501	1-216-049-91	METAL GLAZE 1K	5% 1/10W
R1502	1-208-814-11	METAL CHIP 22K	0 50% 1/10W
R1504	1-216-081-00	METAL GLAZE 22K	5% 1/10W
R1505	1-216-085-00	METAL GLAZE 33K	5% 1/10W
R1506	1-216-049-91	METAL GLAZE 1K	5% 1/10W
R1507	1-208-814-11	METAL CHIP 22K	0 50% 1/10W
R1508	1-216-057-00	METAL GLAZE 2.2K	5% 1/10W
R1509	Δ 1-249-383-91	CARBON 1.5	5% 1/4W F
R1510	1-214-671-11	METAL 3 9	1% 1/4W

The components identified by shading and mark Δ are critical for safety
 Replace only with part number specified

Les composants identifiés par une trame et une marque Δ sont critiques pour la sécurité
 Ne les remplacer que par une pièce portant le numéro spécifié



REF. NO	PART NO	DESCRIPTION	REMARK	REF NO	PART NO	DESCRIPTION	REMARK
R1511	1-214-671-11	METAL 3 9	1% 1/4W	R1803	1-216-073-00	METAL GLAZE 10K	5% 1/10W
R1512	1-215-912-11	METAL OXIDE 150	5% 3W F	R1804	1-216-057-00	METAL GLAZE 2 2K	5% 1/10W
R1513	1-214-671-11	METAL 3 9	1% 1/4W	R1805	1-216-069-00	METAL GLAZE 6 8K	5% 1/10W
R1514	1-216-632-11	METAL CHIP 160	0 50% 1/10W	R1806	1-216-081-00	METAL GLAZE 22K	5% 1/10W
R1515	1-216-639-11	METAL CHIP 330	0 50% 1/10W	R1807	1-216-075-00	METAL GLAZE 12K	5% 1/10W
R1516	1-214-671-11	METAL 3 9	1% 1/4W	R1808	1-216-049-91	METAL GLAZE 1K	5% 1/10W
R1517	1-216-647-11	METAL CHIP 680	0 50% 1/10W	R1809	1-216-081-00	METAL GLAZE 22K	5% 1/10W
R1518	1-216-665-11	METAL CHIP 3.9K	0 50% 1/10W	R1810	1-216-097-91	METAL GLAZE 100K	5% 1/10W
R1519 Δ	1-249-385-91	CARBON 2.2	5% 1/4W F	R1811	1-216-081-00	METAL GLAZE 22K	5% 1/10W
R1520 Δ	1-249-385-91	CARBON 2.2	5% 1/4W F	R1812	1-216-097-91	METAL GLAZE 100K	5% 1/10W
R1521	1-216-049-91	METAL GLAZE 1K	5% 1/10W	R1813	1-216-057-00	METAL GLAZE 2 2K	5% 1/10W
R1522	1-216-049-91	METAL GLAZE 1K	5% 1/10W	R1814	1-216-699-11	METAL CHIP 100K	0 50% 1/10W
R1523	1-216-033-00	METAL GLAZE 220	5% 1/10W	R1815	1-216-697-91	METAL CHIP 82K	0 50% 1/10W
R1551	1-216-081-00	METAL GLAZE 22K	5% 1/10W	R1816	1-216-097-91	METAL GLAZE 100K	5% 1/10W
R1552	1-216-063-91	METAL GLAZE 3 9K	5% 1/10W	R1817	1-216-033-00	METAL GLAZE 220	5% 1/10W
R1553	1-216-077-00	METAL GLAZE 15K	5% 1/10W	R1818	1-216-025-91	METAL GLAZE 100	5% 1/10W
R1554	1-216-049-91	METAL GLAZE 1K	5% 1/10W	R1819	1-216-025-91	METAL GLAZE 100	5% 1/10W
R1559	1-216-073-00	METAL GLAZE 10K	5% 1/10W	R1820	1-216-025-91	METAL GLAZE 100	5% 1/10W
R1562	1-216-025-91	METAL GLAZE 100	5% 1/10W	R1821	1-216-097-91	METAL GLAZE 100K	5% 1/10W
R1603	1-216-663-11	METAL CHIP 3 3K	0 50% 1/10W	R1823	1-208-811-11	METAL CHIP 16K	0 50% 1/10W
R1604	1-216-663-11	METAL CHIP 3 3K	0 50% 1/10W	R1824	1-216-685-11	METAL CHIP 27K	0 50% 1/10W
R1605	1-216-663-11	METAL CHIP 3 3K	0 50% 1/10W	R1825	1-216-685-11	METAL CHIP 27K	0 50% 1/10W
R1606	1-216-663-11	METAL CHIP 3 3K	0 50% 1/10W	R1826	1-216-685-11	METAL CHIP 27K	0 50% 1/10W
R1607	1-216-663-11	METAL CHIP 3 3K	0 50% 1/10W	R1827	1-216-685-11	METAL CHIP 27K	0 50% 1/10W
R1608	1-216-663-11	METAL CHIP 3 3K	0 50% 1/10W	R1828	1-216-685-11	METAL CHIP 27K	0 50% 1/10W
R1610	1-214-729-00	METAL 1K	1% 1/4W	R1829	1-216-685-11	METAL CHIP 27K	0 50% 1/10W
R1612	1-214-729-00	METAL 1K	1% 1/4W	R1830	1-216-025-91	METAL GLAZE 100	5% 1/10W
R1613	1-214-673-00	METAL 4.7	1% 1/4W	R1831	1-216-049-91	METAL GLAZE 1K	5% 1/10W
R1615	1-214-673-00	METAL 4.7	1% 1/4W	R1832	1-216-677-11	METAL CHIP 12K	0 50% 1/10W
R1616	1-214-673-00	METAL 4.7	1% 1/4W	R1833	1-216-049-91	METAL GLAZE 1K	5% 1/10W
R1618	1-214-673-00	METAL 4.7	1% 1/4W	R1834	1-216-049-91	METAL GLAZE 1K	5% 1/10W
R1619	1-214-673-00	METAL 4.7	1% 1/4W	R1835	1-216-025-91	METAL GLAZE 100	5% 1/10W
R1620	1-214-673-00	METAL 4.7	1% 1/4W	R1836	1-216-081-00	METAL GLAZE 22K	5% 1/10W
R1621	1-214-673-00	METAL 4.7	1% 1/4W	R1837	1-208-806-11	METAL CHIP 10K	0 50% 1/10W
R1622	1-214-673-00	METAL 4.7	1% 1/4W	R1838	1-216-667-11	METAL CHIP 4 7K	0 50% 1/10W
R1623	1-214-729-00	METAL 1K	1% 1/4W	R1839	1-216-031-00	METAL GLAZE 180	5% 1/10W
R1624	1-214-729-00	METAL 1K	1% 1/4W	R1840	1-208-806-11	METAL CHIP 10K	0 50% 1/10W
R1625	1-214-673-00	METAL 4.7	1% 1/4W	R1841	1-208-806-11	METAL CHIP 10K	0 50% 1/10W
R1626	1-214-673-00	METAL 4.7	1% 1/4W	R1842	1-216-025-91	METAL GLAZE 100	5% 1/10W
R1627	1-214-673-00	METAL 4.7	1% 1/4W	R1843	1-216-667-11	METAL CHIP 4 7K	0 50% 1/10W
R1628	1-214-673-00	METAL 4.7	1% 1/4W	R1844	1-216-025-91	METAL GLAZE 100	5% 1/10W
R1629	1-214-673-00	METAL 4.7	1% 1/4W	R1845	1-216-077-00	METAL GLAZE 15K	5% 1/10W
R1630	1-214-673-00	METAL 4.7	1% 1/4W	R1846	1-216-125-00	METAL GLAZE 1 5M	5% 1/10W
R1631	1-214-729-00	METAL 1K	1% 1/4W	R1847	1-208-806-11	METAL CHIP 10K	0 50% 1/10W
R1632	1-214-673-00	METAL 4.7	1% 1/4W	R1848	1-216-077-00	METAL GLAZE 15K	5% 1/10W
R1633	1-214-673-00	METAL 4.7	1% 1/4W	R1849	1-216-067-00	METAL GLAZE 5 6K	5% 1/10W
R1634	1-214-729-00	METAL 1K	1% 1/4W	R1850	1-216-097-91	METAL GLAZE 100K	5% 1/10W
R1635	1-214-673-00	METAL 4.7	1% 1/4W	R1851	1-216-043-91	METAL GLAZE 560	5% 1/10W
R1636	1-214-673-00	METAL 4.7	1% 1/4W	R1852	1-216-097-91	METAL GLAZE 100K	5% 1/10W
R1637	1-214-673-00	METAL 4.7	1% 1/4W	R1853	1-216-057-00	METAL GLAZE 2 2K	5% 1/10W
R1638	1-214-673-00	METAL 4.7	1% 1/4W	R1854	1-216-025-91	METAL GLAZE 100	5% 1/10W
R1639	1-214-673-00	METAL 4.7	1% 1/4W	R1855	1-216-097-91	METAL GLAZE 100K	5% 1/10W
R1640	1-214-673-00	METAL 4.7	1% 1/4W	R1856	1-216-025-91	METAL GLAZE 100	5% 1/10W
R1641	1-214-673-00	METAL 4.7	1% 1/4W	R1857	1-216-033-00	METAL GLAZE 220	5% 1/10W
R1642	1-214-673-00	METAL 4.7	1% 1/4W	R1858	1-216-097-91	METAL GLAZE 100K	5% 1/10W
R1717	1-216-033-00	METAL GLAZE 220	5% 1/10W	R1859	1-216-025-91	METAL GLAZE 100	5% 1/10W
R1721	1-216-033-00	METAL GLAZE 220	5% 1/10W	R1860	1-216-025-91	METAL GLAZE 100	5% 1/10W
R1737	1-216-033-00	METAL GLAZE 220	5% 1/10W	R1861	1-216-473-11	METAL OXIDE 56	5% 3W F
R1740	1-216-025-91	METAL GLAZE 100	5% 1/10W	R1862	1-216-473-11	METAL OXIDE 56	5% 3W F
R1748	1-216-033-00	METAL GLAZE 220	5% 1/10W	R1863	1-216-025-91	METAL GLAZE 100	5% 1/10W
R1749	1-216-295-91	CONDUCTOR, CHIP		R1864	1-216-025-91	METAL GLAZE 100	5% 1/10W
R1751	1-216-081-00	METAL GLAZE 22K	5% 1/10W	R1865	1-216-473-11	METAL OXIDE 56	5% 3W F
R1752	1-216-073-00	METAL GLAZE 10K	5% 1/10W	R1866	1-216-473-11	METAL OXIDE 56	5% 3W F
R1753	1-216-295-91	CONDUCTOR, CHIP		R1868	1-216-025-91	METAL GLAZE 100	5% 1/10W
R1760	1-216-295-91	CONDUCTOR, CHIP		R1869	1-216-685-11	METAL CHIP 27K	0 50% 1/10W
R1788	1-208-806-11	METAL CHIP 10K	0 50% 1/10W	R1870	1-216-685-11	METAL CHIP 27K	0 50% 1/10W
R1801	1-216-049-91	METAL GLAZE 1K	5% 1/10W	R1871	1-216-685-11	METAL CHIP 27K	0 50% 1/10W
R1802	1-216-049-91	METAL GLAZE 1K	5% 1/10W	R1872	1-216-685-11	METAL CHIP 27K	0 50% 1/10W



Les composants identifiés par une trame et une marque Δ sont critiques pour la sécurité. Ne les remplacer que par une pièce portant le numéro spécifique

The components identified by shading and mark Δ are critical for safety. Replace only with part number specified

REF NO	PART NO	DESCRIPTION	REMARK
R1873	1-216-685-11	METAL CHIP 27K	0 50% 1/10W
R1874	1-216-685-11	METAL CHIP 27K	0 50% 1/10W
R1875	1-208-824-11	METAL CHIP 56K	0.50% 1/10W
R1876	1-216-025-91	METAL GLAZE 100	5% 1/10W
R1877	1-208-810-11	METAL CHIP 15K	0 50% 1/10W
R1878	1-208-806-11	METAL CHIP 10K	0.50% 1/10W
R1879	1-216-685-11	METAL CHIP 27K	0 50% 1/10W
R1880	1-218-768-11	METAL CHIP 470K	0 50% 1/10W
R1881	1-216-295-91	CONDUCTOR, CHIP	
R1883	1-216-677-11	METAL CHIP 12K	0 50% 1/10W
R1884	1-208-806-11	METAL CHIP 10K	0.50% 1/10W
R1885	1-216-049-91	METAL GLAZE 1K	5% 1/10W
R1886	1-216-031-00	METAL GLAZE 180	5% 1/10W
R1887	1-208-806-11	METAL CHIP 10K	0 50% 1/10W
R1888	1-216-667-11	METAL CHIP 4 7K	0 50% 1/10W
R1889	1-216-667-11	METAL CHIP 4.7K	0 50% 1/10W
R1890	1-216-125-00	METAL GLAZE 1 5M	5% 1/10W
R1891	1-208-806-11	METAL CHIP 10K	0 50% 1/10W
R1892	1-216-061-00	METAL GLAZE 3 3K	5% 1/10W
R1893	1-216-097-91	METAL GLAZE 100K	5% 1/10W
R1894	A 1-249-389-91	CARBON 4.7	5% 1/4W F
R1895	1-216-043-91	METAL GLAZE 560	5% 1/10W
R1896	A 1-249-389-91	CARBON 4.7	5% 1/4W F
R1897	1-216-097-91	METAL GLAZE 100K	5% 1/10W
R1898	1-216-057-00	METAL GLAZE 2 2K	5% 1/10W
R1899	1-216-097-91	METAL GLAZE 100K	5% 1/10W
R1900	1-216-033-00	METAL GLAZE 220	5% 1/10W
R1901	1-216-025-91	METAL GLAZE 100	5% 1/10W
R1902	1-216-025-91	METAL GLAZE 100	5% 1/10W
R1903	1-216-025-91	METAL GLAZE 100	5% 1/10W
R1904	1-216-025-91	METAL GLAZE 100	5% 1/10W
R1905	1-216-097-91	METAL GLAZE 100K	5% 1/10W
R1907	1-208-810-11	METAL CHIP 15K	0 50% 1/10W
R1908	1-208-814-11	METAL CHIP 22K	0 50% 1/10W
R1909	1-216-025-91	METAL GLAZE 100	5% 1/10W
R1910	1-216-685-11	METAL CHIP 27K	0 50% 1/10W
R1911	1-216-685-11	METAL CHIP 27K	0 50% 1/10W
R1912	1-216-685-11	METAL CHIP 27K	0 50% 1/10W
R1913	1-216-685-11	METAL CHIP 27K	0 50% 1/10W
R1914	1-216-685-11	METAL CHIP 27K	0 50% 1/10W
R1915	1-216-685-11	METAL CHIP 27K	0 50% 1/10W
R1916	1-216-025-91	METAL GLAZE 100	5% 1/10W
R1917	1-208-806-11	METAL CHIP 10K	0.50% 1/10W
R1918	1-216-667-11	METAL CHIP 4 7K	0.50% 1/10W
R1919	1-208-822-11	METAL CHIP 47K	0 50% 1/10W
R1920	1-216-667-11	METAL CHIP 4 7K	0 50% 1/10W
R1923	1-216-677-11	METAL CHIP 12K	0 50% 1/10W
R1925	1-216-031-00	METAL GLAZE 180	5% 1/10W
R1926	1-208-806-11	METAL CHIP 10K	0 50% 1/10W
R1927	1-216-125-00	METAL GLAZE 1 5M	5% 1/10W
R1928	1-208-806-11	METAL CHIP 10K	0 50% 1/10W
R1931	1-216-698-11	METAL CHIP 91K	0 50% 1/10W
R1935	1-218-766-11	METAL CHIP 390K	0 50% 1/10W
R1937	1-208-806-11	METAL CHIP 10K	0 50% 1/10W
R1938	1-208-810-11	METAL CHIP 15K	0 50% 1/10W
R1940	1-208-812-11	METAL CHIP 18K	0 50% 1/10W
R1941	1-208-806-11	METAL CHIP 10K	0 50% 1/10W
R1942	1-208-806-11	METAL CHIP 10K	0 50% 1/10W
R1943	1-216-699-11	METAL CHIP 100K	0 50% 1/10W
R1944	1-208-806-11	METAL CHIP 10K	0.50% 1/10W
R1947	1-216-073-00	METAL GLAZE 10K	5% 1/10W
R1948	1-216-093-00	METAL GLAZE 68K	5% 1/10W
R1949	1-216-659-11	METAL CHIP 2 2K	0 50% 1/10W
R1950	1-216-659-11	METAL CHIP 2 2K	0 50% 1/10W
R1951	1-208-806-11	METAL CHIP 10K	0 50% 1/10W
R1952	1-208-806-11	METAL CHIP 10K	0 50% 1/10W
R1954	1-208-806-11	METAL CHIP 10K	0 50% 1/10W
R1955	1-208-806-11	METAL CHIP 10K	0 50% 1/10W
R1956	1-208-800-11	METAL CHIP 5 6K	0.50% 1/10W

REF NO	PART NO	DESCRIPTION	REMARK
R1957	1-208-824-11	METAL CHIP 56K	0.50% 1/10W
R1958	1-208-800-11	METAL CHIP 5.6K	0.50% 1/10W
R1959	1-208-824-11	METAL CHIP 56K	0 50% 1/10W
R1960	1-208-806-11	METAL CHIP 10K	0.50% 1/10W
R1961	1-208-806-11	METAL CHIP 10K	0 50% 1/10W
R1962	1-216-077-00	METAL GLAZE 15K	5% 1/10W
R1963	1-216-073-00	METAL GLAZE 10K	5% 1/10W
R1964	1-216-049-91	METAL GLAZE 1K	5% 1/10W
R1965	1-216-073-00	METAL GLAZE 10K	5% 1/10W
R1966	1-216-073-00	METAL GLAZE 10K	5% 1/10W
R1967	1-216-071-00	METAL GLAZE 8 2K	5% 1/10W
R1970	1-208-774-11	METAL CHIP 470	0 50% 1/10W
R1971	1-216-667-11	METAL CHIP 4 7K	0 50% 1/10W
R1972	1-216-111-91	METAL GLAZE 390K	5% 1/10W
R1981	1-216-473-11	METAL OXIDE 56	5% 3W F
R1982	1-216-473-11	METAL OXIDE 56	5% 3W F
R1983	1-216-077-00	METAL GLAZE 15K	5% 1/10W
R1984	1-216-077-00	METAL GLAZE 15K	5% 1/10W
R1985	1-216-025-91	METAL GLAZE 100	5% 1/10W
TH1501	1-807-925-11	THERMISTOR	
TH1801	1-808-269-11	THERMISTOR	
		<THERMISTOR>	
X1701	1-579-917-11	VIBRATOR, CRYSTAL	
		<CRYSTAL>	
		* A-1372-099-A HA BOARD, COMPLETE	
		<CAPACITOR>	
C1301	1-126-964-11	ELECT 10MF	20% 50V
C1304	1-126-964-11	ELECT 10MF	20% 50V
		<CONNECTOR>	
CN1346	1-564-524-11	PLUG, CONNECTOR 9P	
CN1347	* 1-564-521-11	PLUG, CONNECTOR 6P	
		<DIODE>	
D1304	8-719-053-43	DIODE SLR-325VCT31	
D1305	8-719-053-43	DIODE SLR-325VCT31	
		<IC>	
IC1301	8-741-780-51	IC SBX1780-51	
		<JACK>	
J1301	1-750-517-11	JACK BLOCK, PIN 3P	
		<RESISTOR>	
R1302	1-249-416-11	CARBON 820	5% 1/4W
R1303	1-249-417-11	CARBON 1K	5% 1/4W
R1304	1-249-425-11	CARBON 4 7K	5% 1/4W
R1305	1-249-411-11	CARBON 330	5% 1/4W
R1306	1-249-411-11	CARBON 330	5% 1/4W
R1307	1-249-420-11	CARBON 1 8K	5% 1/4W
R1308	1-247-895-91	CARBON 470K	5% 1/4W



REF. NO.	PART NO.	DESCRIPTION	REMARK	REF NO	PART NO	DESCRIPTION	REMARK
R1309	1-247-895-91	CARBON	470K 5% 1/4W			<CHIP CONDUCTOR>	
R1310	1-249-429-11	CARBON	10K 5% 1/4W				
R1311	1-247-815-91	CARBON	220 5% 1/4W	CJ1101	1-216-295-91	CONDUCTOR, CHIP	
R1312	1-247-804-11	CARBON	75 5% 1/4W			<FILTER BLOCK>	
R1314	1-247-807-31	CARBON	100 5% 1/4W	CM1101	1-473-595-11	COMB FILTER BLOCK	
		<SWITCH>				<CONNECTOR>	
S1301	1-571-731-11	SWITCH, TACTIL		CN1147	* 1-564-509-11	PLUG, CONNECTOR 6P	
S1302	1-571-731-11	SWITCH, TACTIL		CN1150	1-573-300-21	CONNECTOR, BOARD TO BOARD 18P	
S1303	1-571-731-11	SWITCH, TACTIL		CN1155	* 1-565-928-11	CONNECTOR (TUB) 30P	
S1304	1-571-731-11	SWITCH, TACTIL		CN1156	* 1-566-641-11	CONNECTOR, HINGE (TAB) 18P	
S1305	1-571-731-11	SWITCH, TACTIL				<DIODE>	
S1306	1-571-731-11	SWITCH, TACTIL		D1101	8-719-110-17	DIODE RD10ESB2	
S1307	1-571-731-11	SWITCH, TACTIL		D1102	8-719-110-17	DIODE RD10ESB2	
*****				D1103	8-719-110-17	DIODE RD10ESB2	
	* A-1373-511-A	U BOARD, COMPLETE (KP-46S17/53S17)		D1104	8-719-110-17	DIODE RD10ESB2	
		*****		D1105	8-719-110-17	DIODE RD10ESB2	
	* A-1373-562-A	U BOARD, COMPLETE		D1106	8-719-110-17	DIODE RD10ESB2	
		*****		D1107	8-719-110-17	DIODE RD10ESB2	
		(KP-41T25/46S25/53S25)		D1108	8-719-110-17	DIODE RD10ESB2	
				D1109	8-719-110-17	DIODE RD10ESB2	
				D1111	8-719-110-17	DIODE RD10ESB2	
		<CAPACITOR>		D1112	8-719-110-17	DIODE RD10ESB2	
C1101	1-126-965-11	ELECT	22MF 20% 50V	D1113	8-719-110-17	DIODE RD10ESB2	
C1102	1-124-903-11	ELECT	1MF 20% 50V	D1114	8-719-110-17	DIODE RD10ESB2	
C1103	1-124-903-11	ELECT	1MF 20% 50V	D1115	8-719-110-17	DIODE RD10ESB2	
C1104	1-163-031-11	CERAMIC CHIP	0 01MF 50V	D1120	8-719-110-17	DIODE RD10ESB2	
C1105	1-126-965-11	ELECT	22MF 20% 50V	D1121	8-719-921-86	DIODE MTZJ-13	
C1106	1-126-965-11	ELECT	22MF 20% 50V	D1122	8-719-921-86	DIODE MTZJ-13	
C1107	1-124-903-11	ELECT	1MF 20% 50V	D1123	8-719-921-86	DIODE MTZJ-13	
C1108	1-124-903-11	ELECT	1MF 20% 50V	D1124	8-719-921-86	DIODE MTZJ-13	
C1109	1-126-965-11	ELECT	22MF 20% 50V	D1125	8-719-109-84	DIODE RD5 1ESB1	
C1110	1-124-903-11	ELECT	1MF 20% 50V	D1126	8-719-110-17	DIODE RD10ESB2	
C1111	1-124-903-11	ELECT	1MF 20% 50V	D1127	8-719-110-17	DIODE RD10ESB2	
C1121	1-126-935-11	ELECT	470MF 20% 16V	D1135	8-719-991-33	DIODE 1SS133T-77	
C1122	1-163-117-00	CERAMIC CHIP	100PF 5% 50V			<IC>	
C1123	1-124-903-11	ELECT	1MF 20% 50V	IC1101	8-752-068-46	IC CXA1855S	
C1124	1-126-965-11	ELECT	22MF 20% 50V	IC1102	8-759-701-59	IC NJM78M09FA	
C1125	1-124-903-11	ELECT	1MF 20% 50V	IC1102	8-759-701-59	IC NJM78M09FA	
C1126	1-104-665-11	ELECT	100MF 20% 25V			<JACK>	
C1127	1-104-663-11	ELECT	33MF 20% 25V	J1101	1-750-515-11	TERMINAL BLOCK, S 3P	
C1128	1-163-117-00	CERAMIC CHIP	100PF 5% 50V	J1102	1-750-517-11	JACK BLOCK, PIN 3P	
C1129	1-126-965-11	ELECT	22MF 20% 50V	J1104	1-750-517-11	JACK BLOCK, PIN 3P	
		(KP-41T25/46S25/53S25)		J1105	1-750-516-11	JACK BLOCK, PIN 2P	
C1130	1-109-889-11	ELECT	1MF 20% 50V	J1106	1-563-760-11	JACK, MINIATUER (DIA 3 5)	
C1131	1-109-889-11	ELECT	1MF 20% 50V	J1107	1-563-760-11	JACK, MINIATUER (DIA 3 5)	
		(KP-41T25/46S25/53S25)				<COIL>	
C1132	1-124-902-00	ELECT	0 47MF 20% 50V	L1101	1-410-476-11	INDUCTOR 33UH	
C1133	1-126-965-11	ELECT	22MF 20% 50V	L1104	1-410-473-11	INDUCTOR 18UH	
C1134	1-104-665-11	ELECT	100MF 20% 25V	L1105	1-410-494-11	INDUCTOR 1mH	
C1136	1-126-965-11	ELECT	22MF 20% 50V			<TRANSISTOR>	
C1137	1-164-232-11	CERAMIC CHIP	0 01MF 10% 50V	Q1102	8-729-216-22	TRANSISTOR 2SA1162-G	
C1138	1-124-902-00	ELECT	0 47MF 20% 50V	Q1103	8-729-216-22	TRANSISTOR 2SA1162-G	
C1139	1-126-964-11	ELECT	10MF 20% 50V	Q1104	8-729-422-27	TRANSISTOR 2SD601A-Q	
C1145	1-126-934-11	ELECT	220MF 20% 16V	Q1105	8-729-216-22	TRANSISTOR 2SA1162-G	
C1146	1-124-902-00	ELECT	0 47MF 20% 50V	Q1106	8-729-216-22	TRANSISTOR 2SA1162-G	
C1147	1-124-902-00	ELECT	0 47MF 20% 50V				
C1148	1-124-902-00	ELECT	0 47MF 20% 50V				
C1149	1-124-902-00	ELECT	0 47MF 20% 50V				
C1150	1-126-934-11	ELECT	220MF 20% 16V				
C1151	1-126-934-11	ELECT	220MF 20% 16V				
C1152	1-126-934-11	ELECT	220MF 20% 16V				
C1153	1-104-665-11	ELECT	100MF 20% 25V				



REF NO	PART NO	DESCRIPTION	REMARK	REF NO	PART NO	DESCRIPTION	REMARK
Q1107	8-729-422-27	TRANSISTOR 2SD601A-Q (KP-41T25/46S25/53S25)		R1169	1-216-025-91	METAL GLAZE 100	5% 1/10W
Q1108	8-729-422-27	TRANSISTOR 2SD601A-Q		R1170	1-216-041-00	METAL GLAZE 470	5% 1/10W
Q1109	8-729-216-22	TRANSISTOR 2SA1162-G		R1171	1-216-041-00	METAL GLAZE 470	5% 1/10W
Q1110	8-729-216-22	TRANSISTOR 2SA1162-G		R1172	1-216-025-91	METAL GLAZE 100	5% 1/10W
Q1111	8-729-216-22	TRANSISTOR 2SA1162-G		R1173	1-216-025-91	METAL GLAZE 100	5% 1/10W
Q1112	8-729-422-27	TRANSISTOR 2SD601A-Q		R1174	1-216-041-00	METAL GLAZE 470	5% 1/10W
Q1113	8-729-422-27	TRANSISTOR 2SD601A-Q		R1175	1-216-025-91	METAL GLAZE 100	5% 1/10W
Q1114	8-729-422-27	TRANSISTOR 2SD601A-Q		R1176	1-216-025-91	METAL GLAZE 100	5% 1/10W
Q1115	8-729-422-27	TRANSISTOR 2SD601A-Q		R1177	1-216-041-00	METAL GLAZE 470	5% 1/10W
		<RESISTOR>		R1179	1-216-025-91	METAL GLAZE 100	5% 1/10W
R1101	1-216-065-00	METAL GLAZE 4 7K	5% 1/10W	R1180	1-216-025-91	METAL GLAZE 100	5% 1/10W
R1102	1-216-065-00	METAL GLAZE 4 7K	5% 1/10W	R1181	1-216-097-91	METAL GLAZE 100K	5% 1/10W
R1103	1-247-804-11	CARBON 75	5% 1/4W	R1182	1-216-113-00	METAL GLAZE 470K	5% 1/10W
R1104	1-216-065-00	METAL GLAZE 4 7K	5% 1/10W	R1183	1-216-049-91	METAL GLAZE 1K	5% 1/10W
R1105	1-247-804-11	CARBON 75	5% 1/4W	R1184	1-216-113-00	METAL GLAZE 470K	5% 1/10W
R1106	1-247-804-11	CARBON 75	5% 1/4W	R1185	1-216-049-91	METAL GLAZE 1K	5% 1/10W
R1107	1-216-113-00	METAL GLAZE 470K	5% 1/10W	R1186	1-216-061-00	METAL GLAZE 3 3K	5% 1/10W
R1108	1-216-065-00	METAL GLAZE 4 7K	5% 1/10W	R1187	1-216-061-00	METAL GLAZE 3 3K	5% 1/10W
R1109	1-216-113-00	METAL GLAZE 470K	5% 1/10W	R1188	1-216-097-91	METAL GLAZE 100K	5% 1/10W
R1110	1-216-065-00	METAL GLAZE 4 7K	5% 1/10W	R1190	1-216-295-91	CONDUCTOR, CHIP	
R1111	1-216-065-00	METAL GLAZE 4 7K	5% 1/10W	R1191	1-216-295-91	CONDUCTOR, CHIP	
R1112	1-216-065-00	METAL GLAZE 4 7K	5% 1/10W	R1192	1-216-295-91	CONDUCTOR, CHIP	
R1113	1-247-804-11	CARBON 75	5% 1/4W	R1193	1-216-025-91	METAL GLAZE 100	5% 1/10W
R1114	1-216-113-00	METAL GLAZE 470K	5% 1/10W	R1194	1-216-025-91	METAL GLAZE 100	5% 1/10W
R1115	1-216-113-00	METAL GLAZE 470K	5% 1/10W	R1195	1-216-025-91	METAL GLAZE 100	5% 1/10W (KP-41T25/46S25/53S25)
R1116	1-216-095-00	METAL GLAZE 82K	5% 1/10W	R1196	1-216-041-00	METAL GLAZE 470	5% 1/10W
R1117	1-216-095-00	METAL GLAZE 82K	5% 1/10W	R1197	1-216-041-00	METAL GLAZE 470	5% 1/10W
R1118	1-216-095-00	METAL GLAZE 82K	5% 1/10W				
R1119	1-216-025-91	METAL GLAZE 100	5% 1/10W				
R1120	1-216-025-91	METAL GLAZE 100	5% 1/10W				
R1127	1-216-041-00	METAL GLAZE 470	5% 1/10W				
R1129	1-216-041-00	METAL GLAZE 470	5% 1/10W				
R1130	1-216-067-00	METAL GLAZE 5 6K	5% 1/10W				
R1132	1-216-025-91	METAL GLAZE 100	5% 1/10W				
R1133	1-216-067-00	METAL GLAZE 5 6K	5% 1/10W				
R1134	1-216-065-00	METAL GLAZE 4 7K	5% 1/10W				
R1135	1-216-065-00	METAL GLAZE 4 7K	5% 1/10W (KP-41T25/46S25/53S25)				
R1137	1-216-025-91	METAL GLAZE 100	5% 1/10W (KP-41T25/46S25/53S25)				
R1138	1-216-065-00	METAL GLAZE 4 7K	5% 1/10W (KP-41T25/46S25/53S25)				
R1140	1-216-025-91	METAL GLAZE 100	5% 1/10W				
R1141	1-216-041-00	METAL GLAZE 470	5% 1/10W				
R1142	1-216-025-91	METAL GLAZE 100	5% 1/10W				
R1145	1-216-051-00	METAL GLAZE 1 2K	5% 1/10W				
R1146	1-216-051-00	METAL GLAZE 1 2K	5% 1/10W				
R1149	1-216-041-00	METAL GLAZE 470	5% 1/10W				
R1150	1-216-025-91	METAL GLAZE 100	5% 1/10W				
R1151	1-216-025-91	METAL GLAZE 100	5% 1/10W				
R1152	1-216-043-91	METAL GLAZE 560	5% 1/10W				
R1153	1-216-049-91	METAL GLAZE 1K	5% 1/10W				
R1154	1-216-041-00	METAL GLAZE 470	5% 1/10W				
R1155	1-216-049-91	METAL GLAZE 1K	5% 1/10W				
R1156	1-216-043-91	METAL GLAZE 560	5% 1/10W				
R1157	1-216-045-00	METAL GLAZE 680	5% 1/10W				
R1158	1-216-043-91	METAL GLAZE 560	5% 1/10W (KP-41T25/46S25/53S25)				
R1159	1-216-045-00	METAL GLAZE 680	5% 1/10W (KP-41T25/46S25/53S25)				
R1160	1-216-049-91	METAL GLAZE 1K	5% 1/10W				
R1161	1-216-041-00	METAL GLAZE 470	5% 1/10W				
R1162	1-216-041-00	METAL GLAZE 470	5% 1/10W				
R1165	1-249-403-11	CARBON 68	5% 1/4W				
R1166	1-216-113-00	METAL GLAZE 470K	5% 1/10W				
R1167	1-216-113-00	METAL GLAZE 470K	5% 1/10W				
R1168	1-216-113-00	METAL GLAZE 470K	5% 1/10W				

* A-1390-487-A ZR BOARD, COMPLETE (KP-41T25)

 * A-1390-513-A ZR BOARD, COMPLETE

 (KP-46S17/46S25/53S17/53S25)

4-382-854-11 SCREW (M3X10), P, SW (+)

<CAPACITOR>

C1403	1-102-978-00	CERAMIC	220PF	5%	50V	(KP-41T25)
C1404	1-107-638-11	ELECT	33MF	20%	160V	(KP-41T25)
C1405	1-104-665-11	ELECT	100MF	20%	25V	(KP-41T25)
C1406	1-107-370-11	FILM	0 1MF	10%	200V	(KP-41T25)
C1407	1-104-665-11	ELECT	100MF	20%	25V	(KP-41T25)
C1408	1-107-362-11	FILM	0 0047MF	10%	200V	(KP-41T25)
C1409	1-107-667-11	ELECT	2 2MF	20%	160V	(KP-41T25)
C1410	1-107-362-11	FILM	0 0047MF	10%	200V	(KP-41T25)
C1411	1-137-364-11	FILM	0 001MF	5%	50V	(KP-41T25)
C1412	1-137-364-11	FILM	0 001MF	5%	50V	(KP-41T25)
C1413	1-161-830-00	CERAMIC	0 0047MF		500V	(KP-41T25)
C1414	1-104-661-91	ELECT	330MF	20%	16V	(KP-41T25)
C1415	1-102-947-00	CERAMIC	10PF	0 5PF	50V	(KP-41T25)
C1416	1-102-973-00	CERAMIC	100PF	5%	50V	(KP-41T25)

The components identified by shading and mark Δ are critical for safety. Replace only with part number specified.

Les composants identifiés par une trame et une marque Δ sont critiques pour la sécurité. Ne les remplacer que par une pièce portant le numéro spécifié.



REF NO	PART NO.	DESCRIPTION	REMARK
<CONNECTOR>			
CN1411	* 1-580-689-11	PIN, CONNECTOR (PC BOARD) 4P	
CN1412	* 1-564-507-11	PLUG, CONNECTOR 4P	
CN1413	* 1-564-506-11	PLUG, CONNECTOR 3P	
CN1414	* 1-564-509-11	PLUG, CONNECTOR 6P (KP-41T25)	
CN1415	* 1-564-506-11	PLUG, CONNECTOR 3P (KP-46S17/46S25/53S17/53S25)	
CN1415	* 1-564-510-11	PLUG, CONNECTOR 7P (KP-41T25)	
CN1416	1-695-915-11	TAB (CONTACT) (KP-41T25)	
<DIODE>			
D1401	8-719-921-86	DIODE MTZJ-13 (KP-41T25)	
D1402	8-719-921-86	DIODE MTZJ-13 (KP-41T25)	
<TRANSISTOR>			
Q1401	8-729-017-06	TRANSISTOR 2SC4793 (KP-41T25)	
Q1402	8-729-017-05	TRANSISTOR 2SA1837 (KP-41T25)	
Q1403	8-729-140-96	TRANSISTOR 2SD774-34 (KP-41T25)	
<RESISTOR>			
R1401	1-249-414-11	CARBON 560	5% 1/4W
R1402	1-249-414-11	CARBON 560	5% 1/4W
R1405	1-249-417-11	CARBON 1K	5% 1/4W (KP-41T25)
R1406	1-216-479-11	METAL OXIDE 560	5% 3W F (KP-41T25)
R1407	1-249-400-11	CARBON 39	5% 1/4W F (KP-41T25)
R1408	1-249-384-11	CARBON 18	5% 1/4W F (KP-41T25)
R1409	1-249-384-11	CARBON 18	5% 1/4W F (KP-41T25)
R1410	1-247-734-11	CARBON 39	5% 1/2W F (KP-41T25)
R1411	1-249-417-11	CARBON 1K	5% 1/4W F (KP-41T25)
R1412	1-249-414-11	CARBON 560	5% 1/4W (KP-41T25)
R1413	1-249-432-11	CARBON 18K	5% 1/4W (KP-41T25)
R1414	1-249-432-11	CARBON 18K	5% 1/4W (KP-41T25)
R1415	1-249-414-11	CARBON 560	5% 1/4W F (KP-41T25)
R1416	1-216-451-11	METAL OXIDE 120	5% 2W F (KP-41T25)
R1417	1-216-475-11	METAL OXIDE 120	5% 3W F
R1418	1-249-377-11	CARBON 0.47	5% 1/4W F (KP-41T25)
R1419	1-247-815-91	CARBON 220	5% 1/4W (KP-41T25)
R1420	1-216-475-11	METAL OXIDE 120	5% 3W F
R1421	1-249-417-11	CARBON 1K	5% 1/4W (KP-41T25)

* A-1390-489-A ZG BOARD, COMPLETE (KP-41T25) *****			
* A-1390-512-A ZG BOARD, COMPLETE ***** (KP-46S17/46S25/53S17/53S25)			
<CAPACITOR>			
C1433	1-102-973-00	CERAMIC 100PF	5% 50V (KP-41T25)

REF NO	PART NO	DESCRIPTION	REMARK
<CONNECTOR>			
CN1441	* 1-580-689-11	PIN, CONNECTOR (PC BOARD) 4P	
CN1442	* 1-564-507-11	PLUG, CONNECTOR 4P	
CN1443	* 1-564-506-11	PLUG, CONNECTOR 3P	
CN1445	* 1-564-506-11	PLUG, CONNECTOR 3P (KP-46S17/46S25/53S17/53S25)	
CN1445	* 1-564-510-11	PLUG, CONNECTOR 7P (KP-41T25)	
<RESISTOR>			
R1431	1-249-414-11	CARBON 560	5% 1/4W
R1432	1-249-414-11	CARBON 560	5% 1/4W
R1435	1-216-475-11	METAL OXIDE 120	5% 3W F
R1436	1-216-475-11	METAL OXIDE 120	5% 3W F
R1437	1-249-417-11	CARBON 1K	5% 1/4W (KP-41T25)

* A-1390-491-A ZB BOARD, COMPLETE *****			
<CONNECTOR>			
CN1471	* 1-580-689-11	PIN, CONNECTOR (PC BOARD) 4P	
CN1472	* 1-564-507-11	PLUG, CONNECTOR 4P	
CN1473	* 1-564-506-11	PLUG, CONNECTOR 3P	
<RESISTOR>			
R1461	1-249-414-11	CARBON 560	5% 1/4W
R1462	1-249-414-11	CARBON 560	5% 1/4W
R1465	1-216-475-11	METAL OXIDE 120	5% 3W F
R1466	1-216-475-11	METAL OXIDE 120	5% 3W F

MISCELLANEOUS *****			
Δ 1-223-925-21 RESISTOR ASSY (HIGH-VOLTAGE)			
1-417-178-11 SELECTOR, ANTENA (AS-2) (KP-46S17/46S25/53S17/53S25)			
1-504-785-11 SPEAKER (10CM)			
1-556-945-21 CABLE, P-P			
1-557-056-41 CABLE, P-P			
1-561-306-00 JACK, PIN (F) (KP-46S17/53S17)			
Δ 1-769-837-11 CORD, POWER (WITH NOISE FILTER) (7.0A/125V)			
Δ 1-900-211-34 LEAD ASSY, HV			
Δ 8-451-463-11 DEFLECTION YOKE (Y829PA2N)			
Δ 8-451-463-21 DEFLECTION YOKE (Y829PA2N2)			
Δ 8-598-955-00 BLOCK ASSY, HIGH-VOLTAGE			
Δ 8-736-075-05 PICTURE TUBE 07MAC2(G)			
Δ 8-736-076-15 PICTURE TUBE 07MAC2 (B) (KP-41T25/46S17/46S25)			
Δ 8-736-076-25 PICTURE TUBE 07MAC3(B) (KP-53S17/53S25)			
Δ 8-736-077-15 PICTURE TUBE 07MAC2 (R) (KP-41T25/46S17/46S25)			
Δ 8-736-077-25 PICTURE TUBE 07MAC3(R) (KP-53S17/53S25)			

REF. NO	PART NO.	DESCRIPTION	REMARK	REF NO	PART NO	DESCRIPTION	REMARK
		ACCESSORIES AND PACKING MATERIALS *****					
	3-701-627-00	BAG, POLYETHYLENE		* 4-048-105-01	CUSHION (LOWER) (ASSY)	(KP-46S17/46S25)	
	3-856-232-11	MANUAL, INSTRUCTION (KP-46S25/53S25)		* 4-048-579-01	CUSHION (UPPER) (ASSY) (KP-41T25)		
	3-856-233-11	MANUAL, INSTRUCTION (KP-41T25/46S17/53S17)		* 4-048-580-01	CUSHION (LOWER) (ASSY) (KP-41T25)		
	3-856-233-21	MANUAL, INSTRUCTION (Canadian model)		* 4-048-581-01	TRAY (KP-41T25)		
* 4-037-674-01		BOARD, TOP (KP-46S17/46S25)		* 4-048-582-01	INDIVIDUAL CARTON (KP-41T25)		
* 4-041-423-01		SHEET, PROTECTION (KP-41T25/46S17/46S25)		* 4-049-155-01	BAG, PROTECTION (KP-41T25)		
* 4-041-425-01		BAG, PROTECTION (KP-46S17/46S25)		4-050-330-01	LID, SPEAKER GRILLE (KP-46S17/46S25/53S17/53S25)		
* 4-041-426-01		BAG, PROTECTION (KP-53S17/53S25)		* 4-051-491-01	BLOCK, FOAM (KP-53S17/53S25)		
* 4-042-463-01		SHEET, PROTECTION (KP-53S17/53S25)				REMOTE COMMANDER *****	
* 4-047-774-01		PLATE, TOP (KP-53S17/53S25)		1-467-059-21	REMOTE COMMANDER (RM-Y118)	(KP-46S25/53S25)	
* 4-047-775-01		PLATE, BOTTOM (KP-53S17/53S25)		9-903-826-01	POCKET, COVER (FOR RM-Y118)	(KP-46S25/53S25)	
* 4-047-776-01		TRAY (KP-53S17/53S25)					
* 4-047-777-01		INDIVIDUAL CARTON (KP-53S17/53S25)		1-467-621-11	REMOTE COMMANDER (RM-Y121)	(KP-41T25/46S17/53S17)	
* 4-047-778-01		CUSHION (UPPER) (ASSY) (KP-53S17/53S25)		9-903-826-01	POCKET, COVER (FOR RM-Y121)	(KP-41T25/46S17/53S17)	
* 4-047-779-01		CUSHION (LOWER) (ASSY) (KP-53S17/53S25)					
* 4-048-101-01		INDIVIDUAL CARTON (KP-46S17/46S25)					
* 4-048-102-01		TRAY (KP-46S17/46S25)					
* 4-048-103-01		BOARD, BOTTOM (KP-46S17/46S25)					
* 4-048-104-01		CUSHION (UPPER) (ASSY) (KP-46S17/46S25)					